



**NEC**

# ***UNIVERGE SV9500***

---

***DT830/DT430/DT410***  
**USER'S GUIDE**

**NWD-172904-001**  
**ISSUE 3.0**  
**2016 JANUARY**

## **LIABILITY DISCLAIMER**

NEC Corporation reserves the right to change the specifications, functions, or features, at any time, without notice.

NEC Corporation has prepared this document for use by its employees and customers. The information contained herein is the property of NEC Corporation and shall not be reproduced without prior written approval from NEC Corporation. All brand names and product names on this document are trademarks or registered trademarks of their respective companies.

Copyright 2014 - 2016

NEC Corporation

# WARNING

---

## **For Customers in Australia**

Telephone receivers produce magnetic fields that can attract small metallic objects such as pins or staples. To avoid injury, do not place the handset where such objects can be picked up.

## **The Terms and Conditions of Software**

Customers shall use the software embedded in DT830 pursuant to the terms and conditions of software license agreement of the UNIVERGE SV9500 communication server (SLA). The software contains certain third party open source software components which are provided under the terms and conditions designated at [http://www.bcom.nec.co.jp/soft-license/DT800\\_OSS.html](http://www.bcom.nec.co.jp/soft-license/DT800_OSS.html).

The terms and conditions of SLA are not applied to such third party open source software components.

# TABLE OF CONTENTS

---

## 1. INTRODUCTION

FACE LAYOUT .....	1
KEYS AND PARTS .....	6
MENU KEY .....	9
SIMPLE OPERATION BY MENU KEY AND CURSOR KEY .....	11
SHORTCUT MENU .....	12
DISPLAY .....	13
PROGRAMMABLE FEATURE KEYS .....	15
FUNCTION KEY ACTIVITIES .....	16
CONDITIONS FOR DT830 SERIES .....	16
SOFT KEYS .....	17
8LD DISPLAY .....	21

## 2. INSTALLATION PROCEDURE

ADJUSTING ANGLE OF TILT LEG .....	25
CONNECTING LAN CABLE .....	26
CONNECTING LINE CORD .....	27
CONNECTING AC ADAPTER .....	28
INSTALLING DIRECTORY CARD .....	29
INSTALLING/REMOVING LINE KEY CARD .....	29
WALL MOUNTING .....	30

## 3. TERMINAL SETUP

SETUP WITH UP/DOWN KEY .....	33
SETUP WITH FEATURE KEY .....	34
SETUP WITH MENU KEY FOR DT830 SERIES .....	38
SETUP WITH MENU KEY FOR DT430 SERIES .....	87

## 4. BASIC OPERATION

TO LOGIN .....	92
TO LOGOUT .....	93

DISPLAY ENLARGED CHARACTERS .....	93
TO MAKE AN EXTERNAL CALL .....	94
TO MAKE AN INTERNAL CALL .....	96
TO ANSWER AN EXTERNAL CALL .....	97
TO ANSWER AN INTERNAL CALL .....	99
MULTILINE OPERATION .....	100
TO HOLD A CALL .....	100
TO PLACE A CALL ON EXCLUSIVE HOLD .....	101
TO TRANSFER A CALL .....	101
HOW TO INPUT CHARACTERS .....	102
SECURITY MODE .....	115
EMERGENCY CALL .....	117
XML APPLICATION .....	118
SCREEN POP-UP .....	120

## **5.FEATURE OPERATION**

TO ORIGINATE A CALL USING SELECTIVE DIALING (DYNAMIC DIAL PAD, PRESET DIAL) .....	122
TO ORIGINATE A CALL USING SPEED CALLING (ONE-TOUCH SPEED CALLING KEYS).....	123
TO REGISTER NAME ON ONE-TOUCH SPEED CALLING KEY .....	124
TO ORIGINATE A CALL USING SPEED CALLING - STATION/GROUP .....	126
TO ORIGINATE A CALL USING SPEED CALLING - SYSTEM .....	126
ONE-TOUCH SPEED CALLING SETTING USING SPD SET KEY .....	127
TO EDIT THE REGISTERED DATA .....	129
ACCOUNT CODE .....	132
FORCED ACCOUNT CODE.....	132
AUTHORIZATION CODE .....	132

---

VOICE CALL .....	133
TO ANSWER A VOICE CALL Hands-Free .....	134
AUTOMATIC INTERCOM.....	134
MANUAL INTERCOM.....	135
DIAL INTERCOM .....	136
CONFERENCE .....	137
TO SWITCH A CALL WITH TRANSFER KEY .....	137
TO ANSWER A CAMPED-ON CALL.....	138
CALL WAITING - ORIGINATING.....	138
CALL PARK .....	140
CALL PICK-UP (GROUP).....	141
CALL PICK-UP (DIRECT).....	142
OUTGOING TRUNK QUEUING .....	142
OFF-HOOK TRUNK QUEUING.....	142
EXECUTIVE OVERRIDE.....	143
REDIAL.....	144
LAST NUMBER REDIAL .....	145
CALL FORWARDING - ALL CALLS .....	146
CALL FORWARDING - BUSY LINE .....	147
CALL FORWARDING - DON'T ANSWER .....	149
LOGGED OUT IP STATION - CALL DESTINATION .....	150
CALL BACK .....	152
TO SAVE AND REPEAT A NUMBER .....	152
TO LEAVE A MESSAGE .....	153
TO ANSWER A MESSAGE .....	154
VOICE MAIL SYSTEM.....	155
MEET-ME PAGING .....	155
PAGING TRANSFER.....	156
BOSS/SECRETARY TRANSFER.....	157

---

BOSS/SECRETARY - MW LAMP CONTROL .....	158
BOSS SECRETARY OVERRIDE .....	159
DO NOT DISTURB .....	160
CALL REDIRECT .....	161
PRIVACY .....	162
PRIVACY RELEASE.....	163
PHONEBOOK .....	164
CALL HISTORY .....	174
<b>6.DIRECTORY OPERATION</b>	
TO ADD NEW DATA .....	178
TO CHANGE GROUP NAME .....	186
TO FIND REGISTERED DATA.....	188
TO MAKE A CALL FROM DIRECTORY.....	202
TO ADD PREFIX TO NUMBER .....	203
TO EDIT DIRECTORY DATA .....	206
TO DELETE ALL DATA .....	207
TO DELETE SPECIFIC DATA .....	208
<b>7.CALL HISTORY OPERATION</b>	
FOR DT830 SERIES .....	210
TO VIEW CALL HISTORY .....	210
TO MAKE A CALL FROM CALL HISTORY .....	211
TO ADD CALL HISTORY DATA TO DIRECTORY .....	212
TO EDIT DIRECTORY DATA FROM CALL HISTORY .....	214
TO DELETE ALL DATA .....	217
TO DELETE SPECIFIC DATA .....	218
FOR DT430 SERIES .....	219
TO VIEW CALL HISTORY .....	219
TO MAKE A CALL FROM CALL HISTORY .....	222



---

TO DELETE ALL DATA .....	223
TO DELETE SPECIFIC DATA .....	224
<b>8.SPECIFICATIONS</b>	
TECHNICAL SPECIFICATIONS.....	225
<b>MENU LIST</b>	
MENU LIST FOR DT830 SERIES .....	227
MENU LIST FOR DT430 SERIES .....	238
<b>WEB PROGRAMMING</b>	
OUTLINE .....	239
TO LOGIN .....	240
TO LOGOUT .....	242
HOW TO OPERATE .....	244
<b>APPENDIX A OPTION DEVICES</b>	
SMART DEVICE INTEGRATION .....	245
TERMINAL MODE .....	248
OTHER FEATURES .....	251
<b>APPENDIX B HEADSET OPERATION</b>	
ATTACHING THE HEADSET .....	252
TERMINAL OPERATION USING THE HEADSET .....	253
ADJUSTING HEADSET RINGER TONE VOLUME .....	254
HOW TO USE THE WIRELESS HEADSET .....	254

# 1. INTRODUCTION

## FACE LAYOUT

ITZ-8LD-3 (DT830 Series)

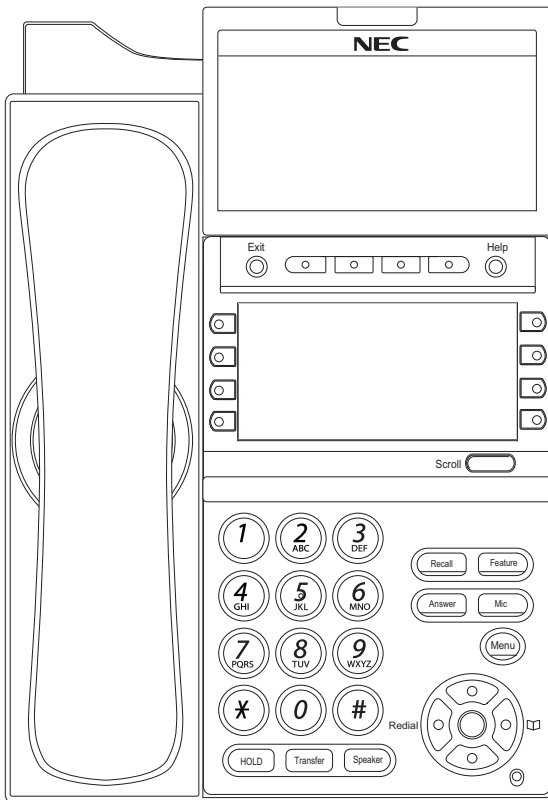

DTZ-8LD-3 (DT430 Series)

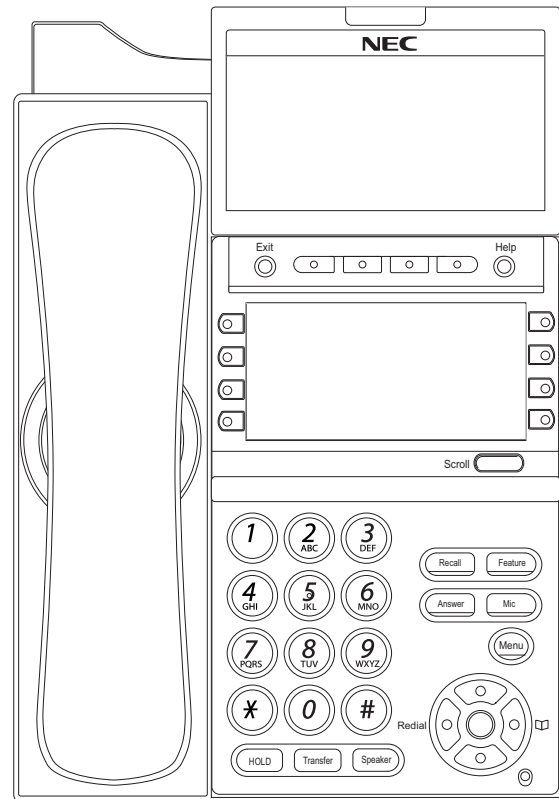

### ITZ-8LDG-3 (DT830 Series)

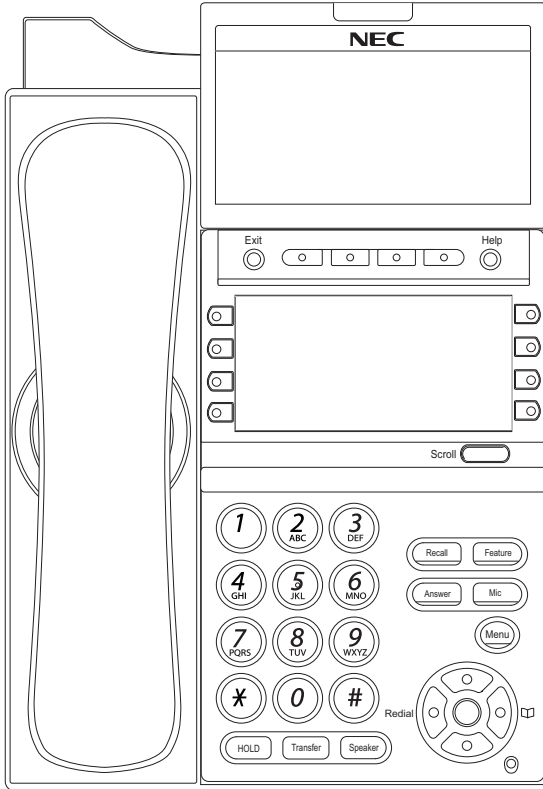

### ITZ-24D-3 (DT830 Series)

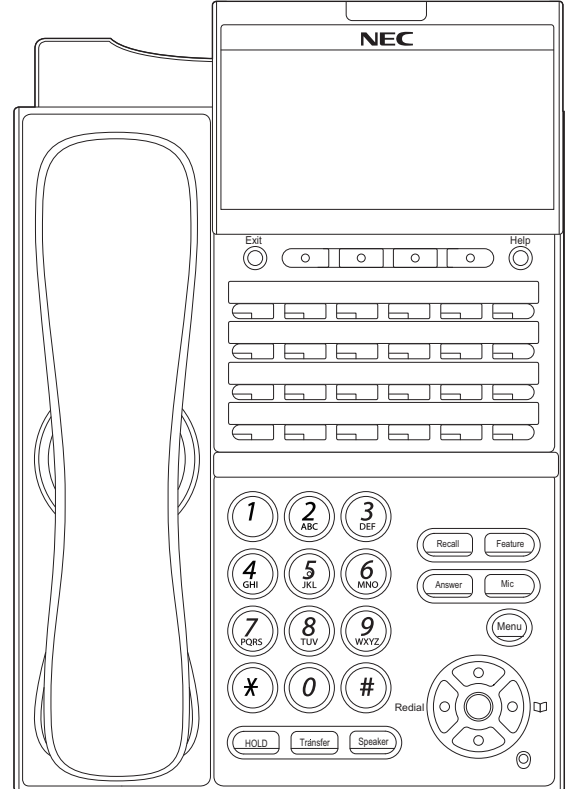

### DTZ-24D-3 (DT430 Series)

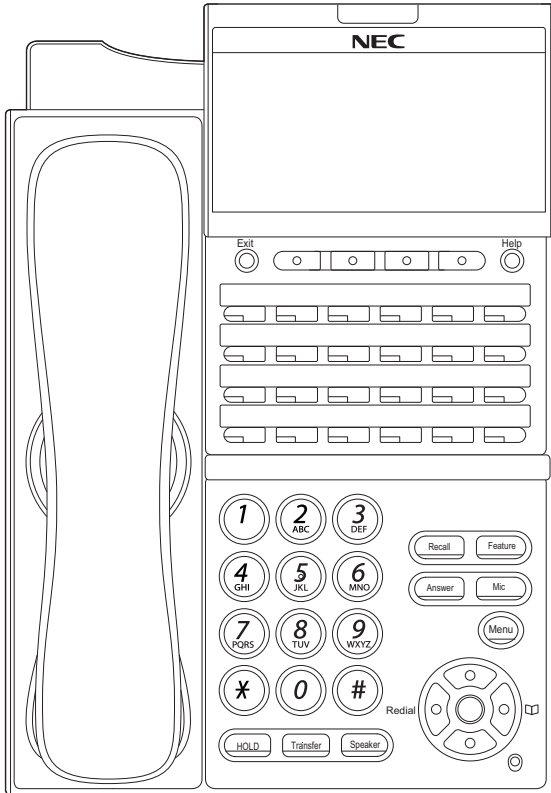

### ITZ-12D-3 (DT830 Series)

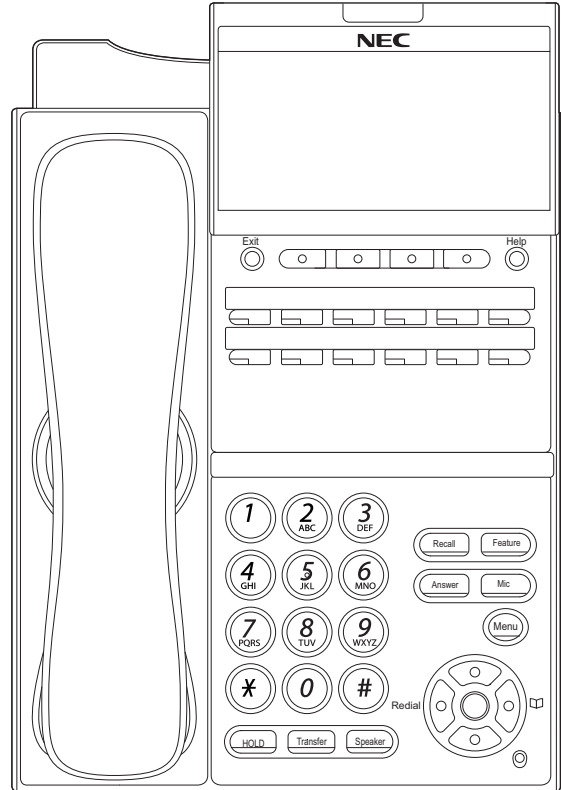

**DTZ-12D-3 (DT430 Series)**

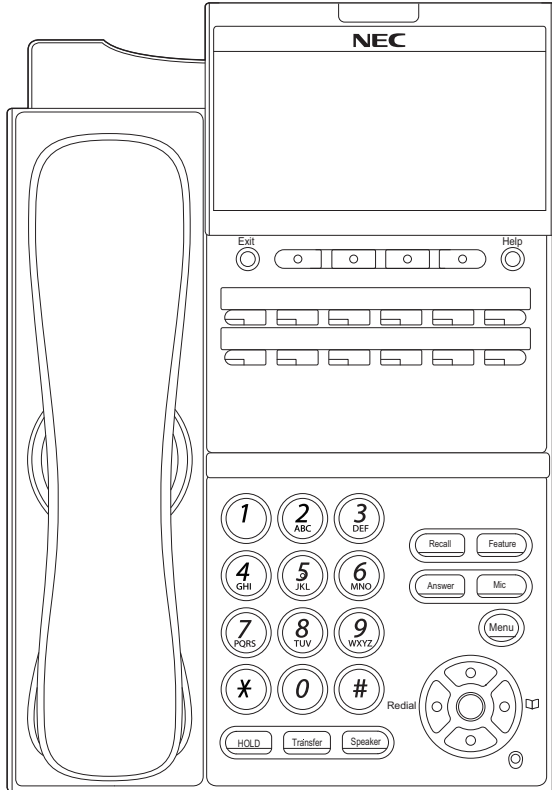

**DTZ-6DE-3 (DT410 Series)**

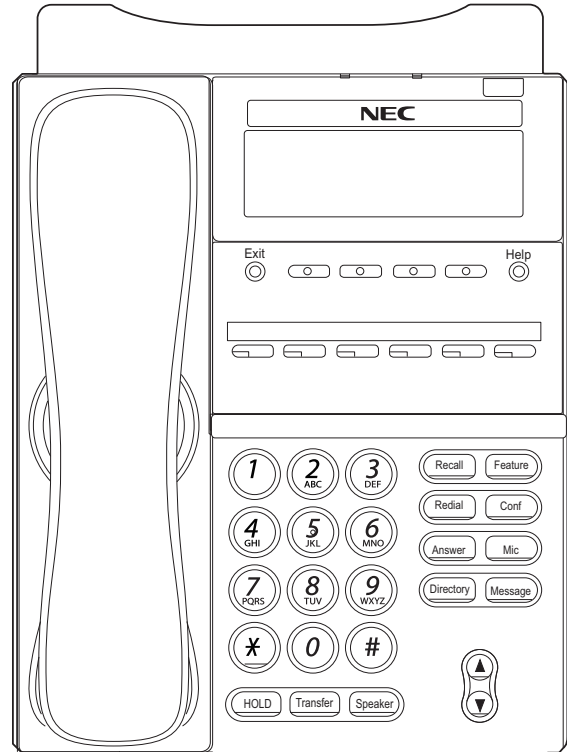

# DTZ-2E-3 (DT410 Series)

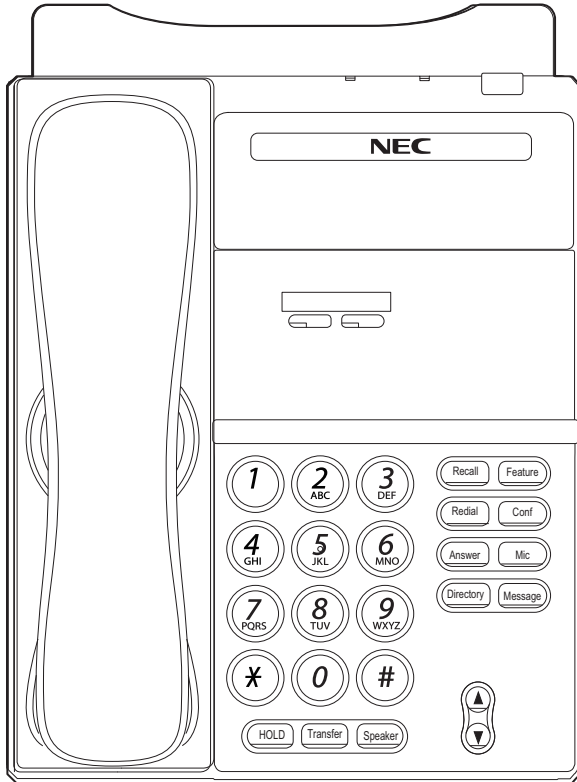

## KEYS AND PARTS

### • KEYS AND PARTS ON ITZ-24D-3

Here explains keys and parts of DT Series taking ITZ-24D-3 as an example.

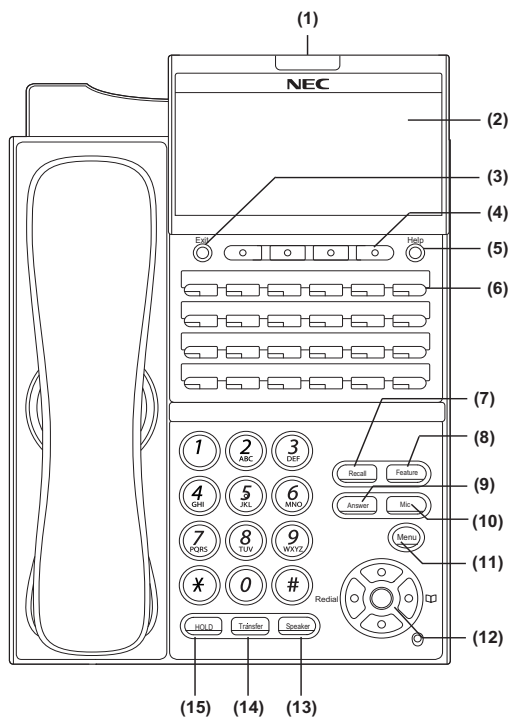

#### (1) Call Indicator Lamp

Lamp at the top corner of the terminal Display flashes when a call terminates to the terminal. Also, when Voice Mail service is available, the Lamp lights to indicate there has been a message.

#### (2) LCD

LCD (Liquid Crystal Display) provides the terminal activity information plus date, time and Soft Key Operation.

#### (3) Exit

To exit Menu or Help mode and go back to the time display.

#### (4) Soft Keys

Any feature shown at the bottom of the LCD is available. The appropriate feature key is displayed on the screen according to the call handling process.

#### (5) Help

Explanations of the Soft Keys can be called up on the LCD by pressing this key.

#### (6) Programmable Keys

These keys can be programmed as Flexible Line key/Programmable Feature Key by Telephony Server administrator.

When Telephony Server administrator sets "One-Touch Speed Dial key" on the programmable keys, you can assign any numbers (ex. Telephone number, etc.) to the key (up to 32 digits).

\* For the assignment of the keys, contact your Telephony Server administrator.

\*\* When two telephone numbers are assigned this key which has a two-page memory (Page 0 and Page 1) of "One-Touch Speed Dial key", you can switch the page with the **PAGE** key.

### (7) Recall

Press this key to finish the call and hear the dial tone.

### (8) Feature

Used to activate any features as terminal setup functions (see [FUNCTION KEY ACTIVITIES](#)), and to program One-Touch Speed Dial Keys.

### (9) Answer

When LED on this key is lit, press this key to answer a waiting call.

### (10) Mic

Press this key to respond hands-free. LED on this key lights during speaker phone operation.



### (11) Menu



To access the local menus of DT830 Series, such as Call History, Directory or Terminal Setting.

### (12) Cursor

By using this key, the terminal user can access to various features with a simple operation.

Also, this key is used as a cursor-movement key on the Menu screen.

	<b>Up</b>	Move the highlighted area one line up the screen.
	<b>Down</b>	Move the highlighted area one line down the screen.
	<b>Left</b>	Go back to the previous screen.

	<b>Right</b>	Go to the screen which corresponds to the highlighted menu item.
	<b>Enter</b>	Go to the screen which corresponds to the highlighted menu item.

#### Details on Cursor key

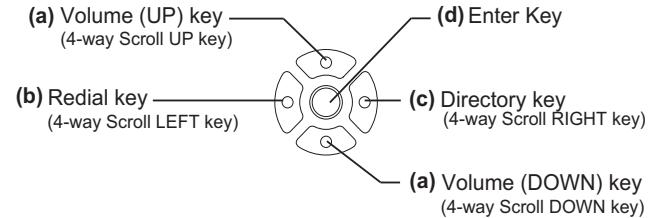

#### (a) UP/DOWN

Used to adjust LCD contrast, speaker/receiver volume, and ringer volume.

- LCD Contrast:  
Press the **UP/DOWN** key while an idle state.
- Speaker/Receiver Volume:  
Press the **UP/DOWN** key during a conversation.
- Ringer Volume:  
Press the **UP/DOWN** key while a terminal is ringing.

#### (b) Redial

(Last Number Call, Speed Calling-Station/Group)  
Press the key to activate redial feature. Press the **Redial** key and scroll back through numbers that have been dialed. When the desired number is displayed, press the ✕ or # key to activate dialing.



**Note:** A-law Countries [Europe, Australia, Russia, Latin America, Middle Near East, other Asian nations]: #  
μ-law Countries [North America, Hong Kong, Taiwan]: ✖

### (c) Directory

Pressing this key opens Directory menu. For details on Directory service, see [6.DIRECTORY OPERATION](#).

### (d) Enter

DT830 Series/DT430 Series have a shortcut menu for frequently-used features. Use this key to display the shortcut menu (see [PROGRAMMABLE FEATURE KEYS](#)) and determine the selected item in the menu.

### (13) Speaker

Controls the built-in speaker which can be used for hands-free dialing/monitoring.  
LED on the key lights when the key is active.

**Note:** DT830/DT430 support for a full duplex hands-free mode. DT410 is a half duplex hands-free mode.

### (14) Transfer

Allows the station user to transfer established calls to another station, without attendant assistance.

### (15) Hold

Press this key to place an internal or external call on hold.

## • THE OTHER KEYS AND PARTS

**Redial** (only for DTZ-2E-3 and DTZ-6DE-3)  
(Last Number Call, Speed Calling-Station/Group)  
Press the key to activate redial feature. Press the **Redial** key and scroll back through numbers that have been dialed.  
When the desired number is displayed, press the ✖ or # key to activate dialing.

**Note:** A-law Countries [Europe, Australia, Russia, Latin America, Middle Near East, other Asian nations]: #  
μ-law Countries [North America, Hong Kong, Taiwan]: ✖

**Conf** (only for DTZ-2E-3 and DTZ-6DE-3)  
Press this key to establish a conversation. LED on the key lights when the key is active.

**Directory** (only for DTZ-2E-3 and DTZ-6DE-3)  
Press this key to activate speed calling - system feature.

**Message** (only for DTZ-2E-3 and DTZ-6DE-3)  
Press this key to access the voice mail system.

**UP/DOWN** (only for DTZ-2E-3 and DTZ-6DE-3)

Used to adjust the LCD contrast, the speaker/receiver volumes, and a ringer volume.

- LCD Contrast:  
Press the **UP/DOWN** key while an idle state.
- Speaker/Receiver Volume:  
Press the **UP/DOWN** key during a conversation.
- Ringer Volume:  
Press the **UP/DOWN** key while a terminal is ringing.

## MENU KEY

From **Menu** key, you can use various application features such as Directory and Call History.

### To Display Menu List



STEP 1: Press **Menu** key while indicating the current time on LCD. The Menu List is displayed in LCD. Use Cursor Key to select the desired Menu Item. You can also select the Menu Item directly using digit keys.

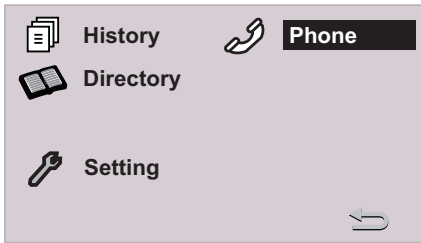



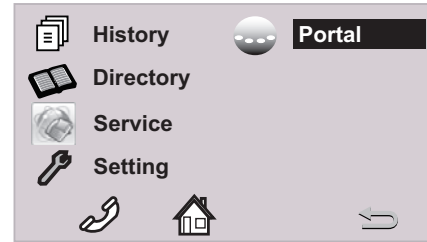

#### Main Menu for DT830 Series without XML application







#### Main Menu for DT830 Series with XML application



Menu Item	Digit key to select	Description
 History	①	To view Call History. There are two types of Call History features. On the one hand, the history data is stored in the server (system) memory. On the other hand, the history data is stored in the memory of the telephone (see <a href="#">7.1FOR DT830 SERIES</a> in chapter 7 Call History Operation).
 Directory	②	To use Directory features. There are the following three types of directory features. <ul style="list-style-type: none"> <li>• Personal Directory: Controlled by telephone set. For details, see <a href="#">6.DIRECTORY OPERATION</a>.</li> <li>• Phonebook: Controlled by the system. For details, see <a href="#">PHONEBOOK</a> in chapter 5.</li> <li>• Corporate Directory: Controlled by the external XML server. <u>For details, please contact the system administrator.</u></li> </ul>

Menu Item	Digit key to select	Description
 Service	③	To access external XML server. For details, please <u>contact the system administrator.</u>  <b>Note:</b> This icon appears only when XML service is used.
 Setting	④	To control settings for ringing volume, LCD display, and Music on Hold. For details, see <a href="#">SETUP WITH MENU KEY FOR DT830 SERIES.</a>
 Phone	⑤	To switch from Main Menu to the Portal screen or Phone screen (time indication screen). <ul style="list-style-type: none"> <li>• When Home URL is registered, Portal icon appears.</li> <li>• When Home URL is not registered, Phone icon appears.</li> </ul> For details, please contact the system administrator.
 Portal		
 XML-1	⑥	To display XML application 1 screen. History or Directory screen being used is treated as an application. This icon is displayed when an XML application starts with a new window.
 XML-2	⑦	To display XML application 2 screen. This icon is displayed when an XML application starts with a new window.

Menu Item	Digit key to select	Description
 XML-3	⑧	To display XML application 3 screen. This icon is displayed when an XML application starts with a new window.
 Phone	Soft Key 1	To switch from application screen to phone screen (Time Indication screen).
 Home	Soft Key 2	XML application screen registered in the home URL is displayed. When the home URL is not registered, Home URL icon is not displayed.
 Return	Soft Key 4	To close the main menu and go back to the previous screen.

**Note:** A Portal screen is the home (entrance) screen of the phone. When you use multiple XML applications, the URL that is registered as the home URL is the Portal screen: this is where other XML applications can be accessed.

### Main Menu for DT430 Series

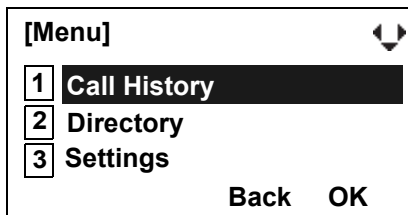

Menu Item	Description
1 Call History	To view Call History. For details, see <a href="#">7.2FOR DT430 SERIES</a> in chapter 7Call History Operation.
2 Directory	To use Phonebook function. For details, see <a href="#">PHONEBOOK</a> in Chapter 5.
3 Setting	To control settings for ringing volume, LCD display. For details, see <a href="#">SETUP WITH MENU KEY FOR DT430 SERIES</a> .

**Note:** DTZ-6DE-3/DTZ-2E-3 does not have Menu key.

**Note:** Unavailable Menu items are grayed out.

## SIMPLE OPERATION BY MENU KEY AND CURSOR KEY

By using  key and  key, the terminal user can access Call History, Directory and terminal settings with simple operation.

As an example, the following operations show how to access the Directory menu.

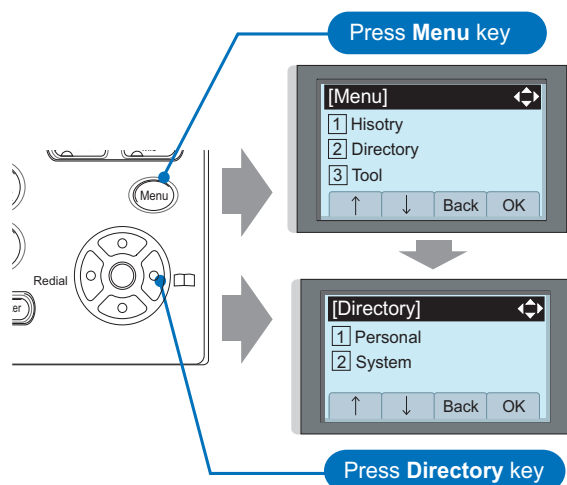

## SHORTCUT MENU

As shown in the figure below, DT830 Series and DT430 Series have a Shortcut Menu for frequently-used features. You can access to Shortcut Menu by pressing  (Enter) key.

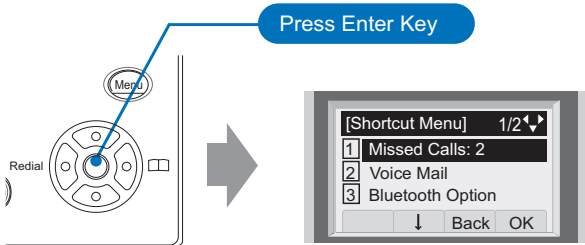

**Note:** DT410 Series do not support the Shortcut Menu.

Shortcut Menu includes the following features.

**Note:** Unavailable Menu items are grayed out.

### Shortcut Menu for DT830 Series

Feature	Description
1 Missed Calls	Access history of Missed Calls.
2 Voice Mail	Access history of incoming Voice Mail.
3 Bluetooth Option	Access the current status of the Bluetooth connection.

### Shortcut Menu for DT430 Series

Feature	Description
1 Missed Calls	Access to history of Missed Call.
2 Voice Mail	Access to history of incoming Voice Mail.

As an example of DT830 Series, the following shows how to view the log data of missed a call from the Shortcut menu.

STEP 1: Press  (Enter) key. The Shortcut menu screen is displayed on LCD.

STEP 2: Select **1 Missed Calls** and then press ,  (Right-cursor) or the **OK** soft key.

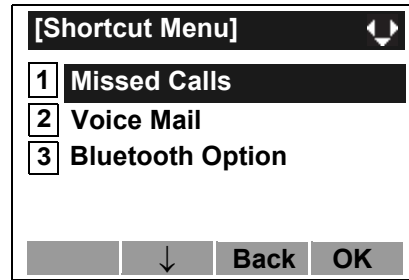

STEP 3: The log data of the last call is displayed.

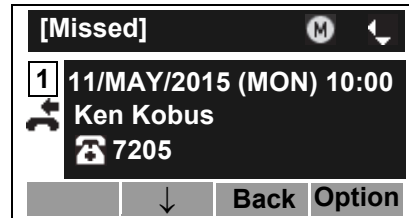

**Note:** If two or more records exist, use  or the **UP/DOWN** soft key to display the next/former records.

**Note:** For unanswered incoming calls,  will be displayed on the left of the name.

**Note:** If you make/answer a call to/from the telephone number which is registered to Personal Directory, the corresponding name will be displayed as call history data.





STEP 4: Press  (**Enter**) key while displaying the log data for the target telephone number on LCD.

**Note:** While the log data is displayed, you cannot make a call by dialing a telephone number.

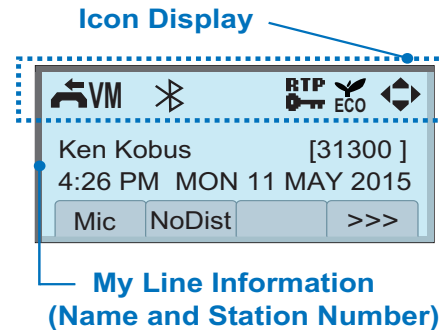
## DISPLAY

The LCD of DT830 Series and DT430 Series display Desktop Icons which provide notification when events (such as missed a call and a voice mail) occur.



Feature	Icon	Description
Missed Call		This icon appears when there is a missed call. Once you have checked the missed call, this icon will disappear.
Voice Mail		This icon provides notification of received Voice Mail. Once you have checked the Voice Mail, this icon will disappear.
Bluetooth		This icon appears when a cordless handset or Bluetooth® Connection Adapter (BCA-Z) is connected to DT830 Series/DT430 Series.
Encryption		This icon appears when the conversation is encrypted. This icon is displayed for DT830 Series only.
Power Save		This icon appears when the terminal is in power save mode. This icon is displayed for DT830 Series only.

Feature	Icon	Description
Cursor		This icon indicates the currently available direction of the Cursor key.

**Note:** The LCD can display the My Line information (name and station number) when the station is in an idle state. For details, please contact the system administrator.

**Note:** The Bluetooth® word mark and logos are registered trademarks owned by Bluetooth SIG, Inc. and any use of such marks by NEC Corporation is under license.

**Note:** Power save mode can be set at installation. For details, please contact the system administrator.

## PROGRAMMABLE FEATURE KEYS

These are examples of the terminal features available by pressing the programmable keys. Some features using feature access code may be programmed by the user. Others must be programmed by the telephone system administrator.

### **LED**

Programmable Feature keys have a built-in Light Emitting Diode (LED) that lights or flashes according to the activity of the Feature key.

### **AICM:**

Press the key to activate “Automatic Intercom”.

### **DICM:**

Press the key to activate “Dial Intercom”.

### **NoDist (Do Not Disturb):**

Press the key to activate or cancel “Privacy” feature.

### **CF-All:**

Press the key to activate or cancel “Call Forwarding – All Calls” feature.

### **CF-Busy:**

Press the key to activate, verify, or cancel “Call Forwarding – Busy Line” feature.

### **CF-NoAns:**

Press the key to activate, verify, or cancel “Call Forwarding – Don’t Answer” feature.

### **MICM:**

Press the key to activate “Manual Intercom”.

### **MSG (Message):**

Press the key to leave a message indication at a station in no answer or busy condition.

### **MSG Wait:**

Press the key to leave a message waiting indication on boss’ station from secretary’s station.

### **no MSGwt:**

Press the key to cancel a message waiting indication on boss’s station from secretary’s station.

### **Priv.Rel:**

Press the key to release “Privacy” feature.

### **Save&Rep (Save and Repeat):**

Press the key to store a number or redial a stored number.

### **Signal:**

Press the key to cause chime at a predetermined station.

### **SPD Name:**

Press the key to register name for the key to **One-Touch Speed Calling** key.

### **Reverse:**

Press the key to reverse the black and white in its display: background, characters and icons.

### **MULTILINE APPEARANCE:**

You can see the caller information (such as a caller ID or a name) using the programmable key (which is programmed for a multiline by the system administrator) during an incoming call. For details, see [MULTILINE OPERATION](#) in chapter 4.



## FUNCTION KEY ACTIVITIES

- Feature + 0 = Side Tone On/Off (for handset)
- Feature + 1 = Turns microphone on or off.
- Feature + 2 = Adjusts handset receiver volume.
- Feature + 3 = Selects ringer tone.
- Feature + 4 = Adjusts transmission/receiving volume.
- Feature + 5 = Activates hands-free operation.
- Feature + 6 = Deactivates hands-free operation.
- Feature + 7 = Turns call indicator lamp on or off for incoming call notification (If turned off, this lamp will still light to indicate message waiting.)
- Feature + 8 = Selects between Normal, Dynamic Dial Pad, and Preset Dial.

## CONDITIONS FOR DT830 SERIES

Please note that following terminal settings (by Feature Key + Digit Key) cannot be used for DT830 Series.

- **Feature+0** =Side Tone On/Off (for handset)  
**For the settings, contact the administrator.**  
*\* You can confirm the settings in “Audio&Visual Settings” → “Side Tone Volume” of Online Monitoring.*
- **Feature+2** =Adjusts handset receiver volume  
**For the settings, contact the administrator.**  
*\* You can confirm the settings in “Audio&Visual Settings” → “Audio Settings” → “Receive Bias”/“Receive Gain” of Online Monitoring.*
- **Feature+3** =Selects ringer tone  
**For the settings, contact the administrator.**  
*\* You can confirm the settings in “Audio&Visual Settings” → “Audio Settings” → “Ring Settings” of Online Monitoring.*
- **Feature+4** =Adjusts transmission/receiving volume  
**For the settings, contact the administrator.**  
*\* You can confirm the settings in “Audio&Visual Settings” → “Audio Settings” → “Receive Bias”/“Receive Gain”/“Send Gain” of Online Monitoring.*
- **Feature+5** =Activates hands-free operation  
**Not Available**
- **Feature+6** =Deactivates hands-free operation  
**Not Available**

## SOFT KEYS

The Soft Keys provide a set of functions on the LCD that adapt to the changing state of the telephone. While default soft key settings are provided, desired functions can be assigned to individual stations as required. The soft keys, at the bottom of the LCD, can display the names of available functions, names of user-assigned functions and names of functions assigned by a specific soft key pattern. Displayed soft keys can vary, depending on the state of the phone and/or when the Next/Previous key is pressed.

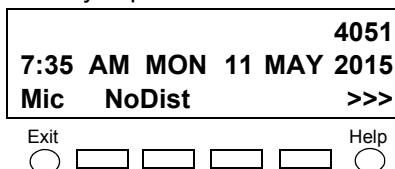

**Note:** For DT830 Series, eight digits characters are displayed on the LCD. For other terminals, the soft key indication characters are displayed as six digits without a frame. For the details, contact the system administrator.

**Note:** The soft key function is available for the terminals with LCD.

### Default Displays for Each Status

Different patterns of soft key settings can be registered for individual call status and assigned to individual terminals as required.

Default soft key settings are provided corresponding to particular functions. Different soft key settings are displayed at the bottom of the LCD depending on the status, as follows:

### IDLE



### DIAL TONE/DIALING



Push >>>

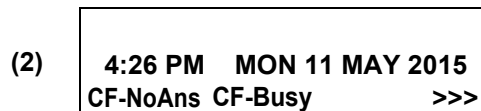

### RINGING

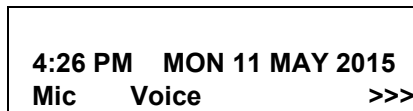

## BUSY

(1)

<b>BUSY</b>	<b>2000</b>
<b>4:26 PM MON 11 MAY 2015</b>	
<b>Mic CallBack CallWait &gt;&gt;&gt;</b>	

Push >>>

(2)

<b>BUSY</b>	<b>2000</b>
<b>4:26 PM MON 11 MAY 2015</b>	
<b>Save&amp;Rep &gt;&gt;&gt;</b>	

## CONNECTION

	<b>2000</b>
<b>4:26 PM MON 11 MAY 2015</b>	
<b>Mic NoDist &gt;&gt;&gt;</b>	

## CONSULTATION HOLD

<b>TRANSFER</b>	<b>2000</b>
<b>4:26 PM MON 11 MAY 2015</b>	
<b>Mic Conf. &gt;&gt;&gt;</b>	

## Soft Key Features

When the soft key corresponding to a desired feature name is operated, the selected feature name starts to blink on the LCD. The blinking display of available features takes precedence over the display of features specified by the soft key pattern.

**Note:** The soft keys can be programmed in System Data to blink, remain steady, have no indication, or display a character when either in use or idle.

The following shows the default display patterns of main features.

### CF-Busy/FDB (Call Forwarding - Busy Line)

Permits a call to a busy station to be immediately forwarded to a predesignated station.

### CF-All/FDA (Call Forwarding - All Calls)

Permits all calls designated for a particular station to be routed to another station regardless of the busy or idle status of the called station.

### CFLogout/FDL (Logged Out IP Station - Call Destination)

Enables a system to transfer the call to appropriate station when the terminal whose LOGGED OUT IP STATION - CALL DESTINATION has already been registered is in logout status.

### Exe-Over/E-OVR (Executive Override)

Enables selected station users, upon encountering a busy condition at an internal station, to bridge into the busy connection.

### CallWait/CW (Call Waiting)

Enables a busy station to receive a second incoming call. A camp-on indication tone is sent to the busy station, and you can use a switchhook flash to answer the second call.

### CallBack/CB (Call Back)

Provides the ability for a calling station to set a CALL BACK. The calling station will be rung as soon as the busy station becomes available.

### Save&Rep/S&R (Save and Repeat)

Allows a station to save a specific dialed number and then redial that number later.

**MSG Wait/MWSET (Message Waiting - Set)**

Allows a station to set a Message Waiting indication or lamp.

**CallHold/HOLD (Call Hold)**

Permits a station user to hold a call in progress and to return to the previously held call.

**no MSGwt/MWOFF (Message Waiting - Cancel)**

Allows a station to cancel a Message Waiting indication or lamp.

**PickUP/PICK (Call Pickup - Group)**

Permits a station user to answer any calls directed to other lines in the user's preset Call Pickup Group.

**Conf./CONF (Three-way Calling)**

Enables a station user to establish a three-way conference by connecting an additional party to an already existing conversation.

**Voice/VOICE (Voice Call)**

Enables you to make a call to the called party's built-in speaker. If the called party's Mic is on, the called party can converse on hands-free.

**SysSpeed/S-SPD (Speed Calling - System)**

Allows a station user to call certain frequently dialed numbers using fewer digits (abbreviated call codes) than would normally be required.

**CAS SHF/CAS (CAS-Switch Hook Flash)**

Allows you to send a switchhook flash while on an outside trunk.

**Busy Out/UCDBO (UCD Busy Out)**

Allows a station user to block UCD calls and to cancel

Busy Out.

**Flash/FLASH (Flash)**

Provides the station with a switchhook flash.

**CF-NoAns/FDN (Call Forward - No Answer)**

Permits a call to an unanswered station to be forwarded to a predesignated station if the called station does not answer within a predetermined period of time.

**MC-Trace/C-RPT (ISDN Malicious Call Trace)**

Allows you to initiate a Call Trace on ISDN calls only.

**GrpSpeed/G-SPD (Speed Calling - Group)**

Allows a station user to share a set of common Speed Calling numbers with other station users in the group.

**Priv.Rel/P-RLS (Privacy Release)**

Allows another station user to press a busy line key and enter the conversation of a station already engaged in communication.

**NoDist/DND (Do Not Disturb)**

Allows a station user to deny access to the station line for incoming calls.

**Mic/MIC (Microphone On/Off)**

Allows you to turn the microphone on and off for use with the speakerphone. LED on the **Mic** key illuminates when the Microphone is on.

**Page/PAGE (Button Page)**

Allows you to toggle between pages when two numbers are registered on One-Touch Speed Calling key.

**Headset/HSET (Headset)**

Allows you to go off-hook and on-hook when using the headset.

### **Release/RLS (Release Key)**

Allows you to release the current call when using the headset, without waiting for the party to hang up.

### **Signal/SIG (Manual Signaling)**

Permits station users to send a one-second ring to a predetermined station. If the signaled station is ringing from another call, the manual intercom signal will interrupt that ringing.

### **CallKeep/CKEEP (Eight-Party Conference Retrain)**

Allows all outside parties to stay on a conference when all internal parties hang up.

### **Serial/SCALL (Serial Call)**

Allows you to set Serial Call for the caller before extending the call, allowing the caller to receive an announcement at the end of the call guiding the caller to dial the next number and subsequent numbers.

### **IZPaging/IZP (Internal Zone Paging)**

Allows a user to make a voice call through the speakers of the designated group.

### **IDChange/IDCHG (Call ID Change Display)**

Allows you to toggle between standard display and an alternate display.

### **G-PickUp/GPICK (Call Pickup - Group Enhancement)**

Allows you to answer any ringing station within your expanded call pickup group.

### **CH Conf./CHCNF (Call Hold - Conference)**

Allows a station user to establish a conference connection by adding a third party, who is held on

another line, to the existing two-party connection.

### **Visitor/VISIT (Survivable Remote MGC)**

Allows a station to indicate a status: when a user is in remote office, VISIT will be blinking. After recovering the main office, VISIT will return to light.

### **RingMute/RMUTE (Ringer Mute)**

Allows a station user to mute or recover station ringing.

### **Reverse/RVERS:**

Allows you to reverse the black and white in its display: background, characters, and icons.



1:25 PM MON 11 MAY 2015  
Mic NoDist Reverse >>>

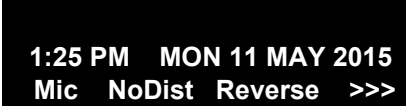

1:25 PM MON 11 MAY 2015  
Mic NoDist Reverse >>>

**Note:** Not available for DT410 Series.

### **SPD Set/SPDSET (One-Touch Speed Calling)**

Allows you to add, edit, or delete the One-Touch Speed Calling key.

### **>>> (Display Function Next Page)**

Allows you to scroll to the next screen.

### **<<< (Display Function Previous Page)**

Allows you to scroll to the previous screen.

## 8LD DISPLAY

8LD Display is available for DTZ-8LD-3, ITZ-8LD-3, and ITZ-8LDG-3.

### DTZ-8LD-3/ITZ-8LD-3/ITZ-8LDG-3

These terminals provide 32 (8 keys x 4 pages additional programmable keys) keys. Also, information set to each programmable key is displayed on DESI-less screen. For setting of the programmable key, contact Telephony Server administrator.

When Telephony Server administrator sets “One-Touch Speed Dial key” on the programmable keys, you can assign any numbers (ex. Telephone number, etc.) to the key (see [TO ORIGINATE A CALL USING SPEED CALLING \(ONE-TOUCH SPEED CALLING KEYS\)](#) and [TO REGISTER NAME ON ONE-TOUCH SPEED CALLING KEY](#)).

\* For the assignment of the keys, confirm with the Telephony Server administrator.

### DTZ-8LD-3/ITZ-8LD-3/ITZ-8LDG-3

#### Time Indication Screen

(Indicates current time information, call information, and Soft Keys, etc.)

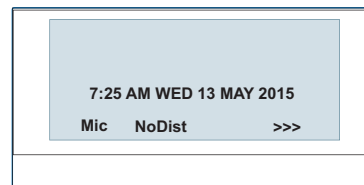

#### DESI-less Screen

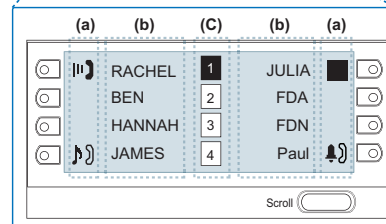

### (a) Icon

Status information on the Line key such as Call termination, Call Hold or Busy can be indicated as following Icons.

User Status	Icon	Flashing Pattern
• Idle	No Icon	-
• Call Hold (Individual Hold/Individual Hold on Call Park Group) • Call Forwarding-All Calls (When “Call Forward Line Lamp Indication” feature is set)		Blink
• Call Hold (Other Party Hold/Other Party Hold on Call Park Group)		
• Recall (Individual Hold/Exclusive Call Hold/Call Transfer/Individual Hold on Call Park Group)		
• Receiving an Incoming Call		Steady Lit
• During Conversation (Individual Use) • Call Transfer • Conference		
• During Conversation (Other Party Use) • Active Feature (Under a setting of feature key like a “Call Forwarding”)		

### (b) Programmable Key Information

Programmable Key Information displays the followings.

Key	Description	Maximum digits to be displayed
<b>Line Key</b>	- Name and Number information	8 digits
<b>One-Touch Speed Dial Key</b>	- Speed Dial Name Information - Number Information	8 digits
<b>Feature Key</b>	- Feature Name	11 digits <b>Note1</b>

**Note1:** Depending on the configuration setting, the maximum number of digits may be displayed as 6 digits. For details, contact the system administrator.

### (c) Page Icon

DESI-less screen has four pages (8 programmable keys per page). Page Icon key indicates currently displayed page. You can switch the programmable key display from page 1 to 4 by using **Scroll** key.

<b>1</b>	Programmable Key 1-8	Black background indicates currently displayed page.
<b>2</b>	Programmable Key 9-16	
<b>3</b>	Programmable Key 17-24	Flashing indicates page with event happening.
<b>4</b>	Programmable Key 25-32	

**Note:** The icon flashes during events such as call termination to a line key or call back.

**Example: Page Turning by Scroll Key**

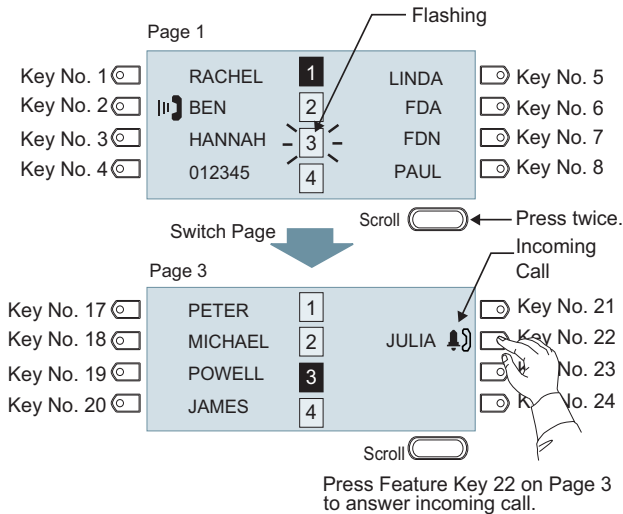

**Note:** For example, when an incoming call is terminated to a line key on Page 3 while Page 1 is being displayed on the screen, the screen is not automatically switched from Page 1 to page 3. You must display Page 3 manually and then answer the incoming call.

**(d) Programmable Key Indication**

The following shows LCD indication of Programmable keys.

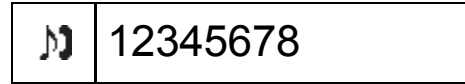

- OR -



Appropriate icons are displayed according to the feature. These displays cannot be changed by user.

The following shows each LCD indication when One-Touch Speed Dial key is set to Programmable key.

**When a Station line/Trunk line is assigned.**

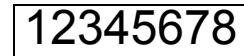

- OR -





No icons are displayed.

\* You can register name on each One-Touch Speed Dial key. For the procedures, see [TO REGISTER NAME ON ONE-TOUCH SPEED CALLING KEY](#).

**When any features using feature access code are assigned.**



Black square icons are displayed.

\* You can register name on each One-Touch Speed Dial key. For the procedures, see [TO REGISTER NAME ON ONE-TOUCH SPEED CALLING KEY](#).

### **(e)Scroll Key**

#### **DTZ-8LD-3, ITZ-8LD-3, ITZ-8LDG-3**

This key is used to turn over the page of DESI-less screen.

**Note:** The following key operations are not available while DESI-less screen is displayed.

- Soft Key
- Help Key
- Exit Key
-  Right-cursor key and  Left-cursor key

# 2. INSTALLATION PROCEDURE

## ADJUSTING ANGLE OF TILT LEG

**DT830 DT430/410**

The angle of the tilt leg can be adjusted in four levels.

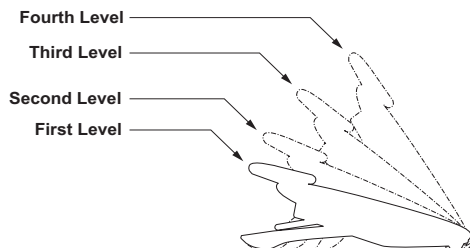

### • TO RAISE TILT LEG

STEP 1: Turn the telephone set upside down.

STEP 2: Adjust the angle of the tilt leg by pulling the leg in the direction of the arrow. The leg clicks when it is in position.

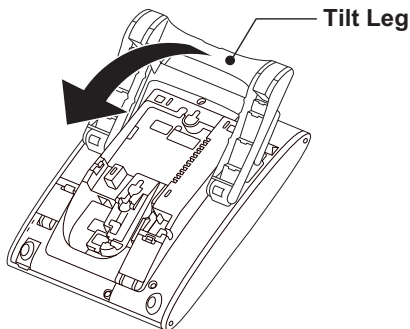

STEP 3: Turn the telephone set upside down again.

### • TO LOWER TILT LEG

STEP 1: Turn the telephone set upside down.

STEP 2: While lifting the center of the stopper, push the tilt leg in the direction of the arrow. The leg clicks when it is in position.

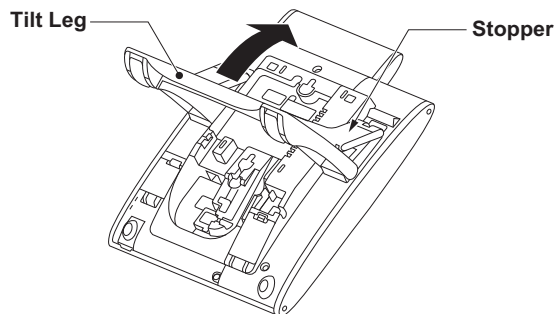

STEP 3: Turn the telephone set upside down again.

- **TO CONFIRM THE ANGLE ADJUSTMENT**

Confirm that the tilt leg and the stopper are joined correctly. If they are not joined correctly, join the stopper's junction to the recessed point of the tilt leg.

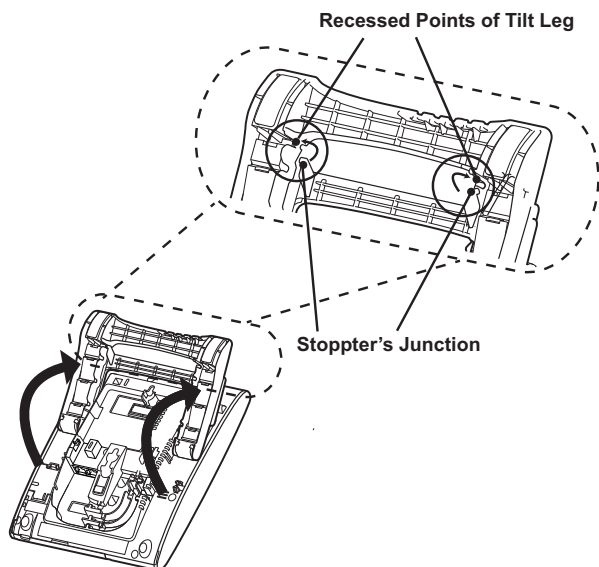

## CONNECTING LAN CABLE

### DT830

- STEP 1: Prepare 10 BASE-T/100 BASE-TX/1000BASE-T (8LDG only) cables (Straight) for connecting the telephone to network devices such as HUB or PoE Switch.
- STEP 2: Connect the telephone to the network device using the LAN cable.
- STEP 3: Thread the LAN cable through the groove on the back of the telephone.

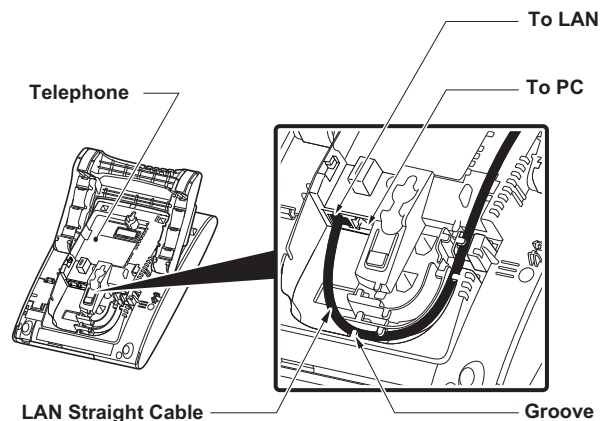

STEP 4: When an AC adapter is used to supply power to the telephone, connect the AC/DC adapter to the telephone as shown below.

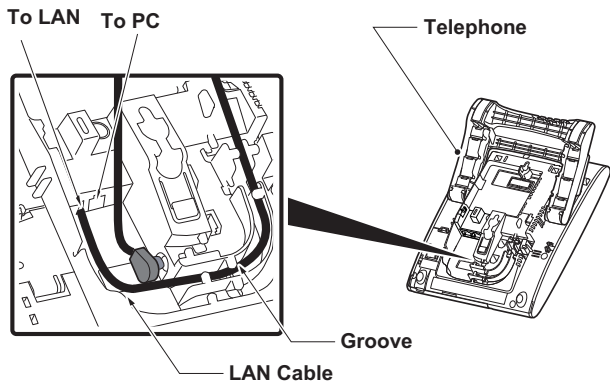

## CONNECTING LINE CORD

### DT430/410

STEP 1: Insert a Line cord plug into the Line connector on the back of the telephone set until you hear it click.

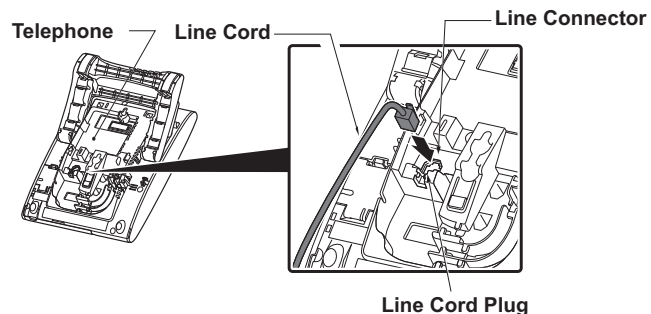

STEP 2: Thread the line cord through the groove on the back of the telephone.

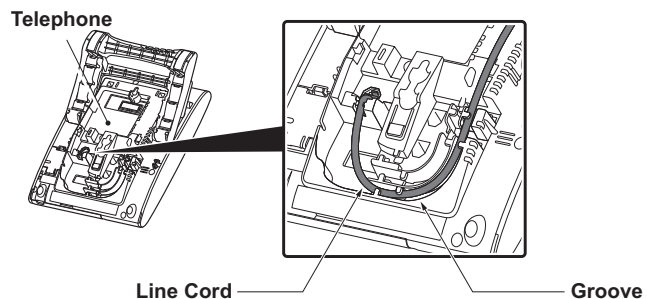

STEP 3: Lead the line cord out through the groove on the tilt leg as shown in the figure below.

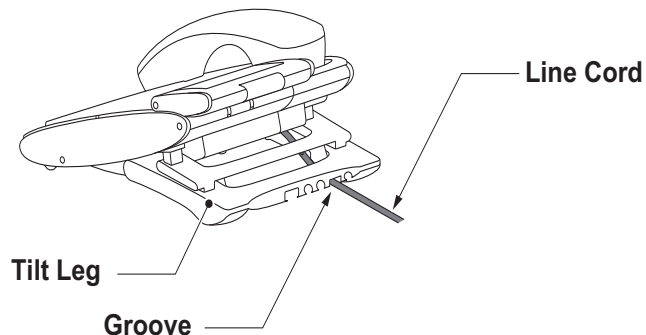

## CONNECTING AC ADAPTER

**DT830** **DT430**

STEP 1: Insert the AC adapter plug into the connector of the AC adapter (AC-L UNIT) on the back of telephone.

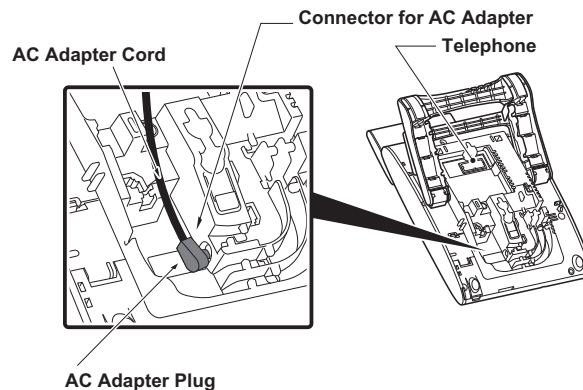

STEP 2: Fix the AC adapter cord through the groove on the back of telephone.

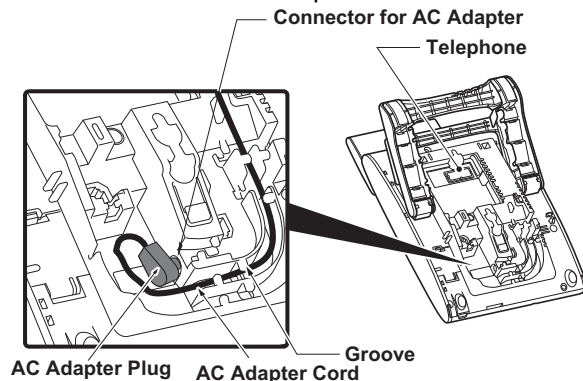

**Note:** When you remove the AC adapter from the terminal, disconnect the LAN cable beforehand.

## INSTALLING DIRECTORY CARD

**DT830 DT430/410**

An optional directory card (also known as an abbreviated dialing table) can be attached to the telephone sets. The directory card can be used to record often dialed numbers or other important information.

**Note:** To remove the directory card, pinch both sides of the directory card holder inward until the tabs release and pull the holder out of the grooves.

STEP 1: Remove the protective sheet from the cover.

STEP 2: Attach the cover to the directory card and then attach it to the directory card holder.

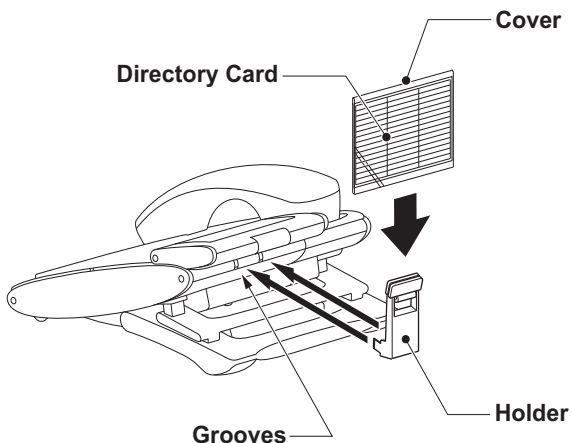

## INSTALLING/REMOVING LINE KEY CARD

**DT830 DT430/410**

### • TO REMOVE KEY SET UNIT (LINE KEY PANEL AND LINE KEY CARD)

STEP 1: Insert the tip of a tool (such as a small screwdriver) into the right side of the line key panel.

STEP 2: Pull the line key panel out of the telephone.

STEP 3: Remove the line key card.

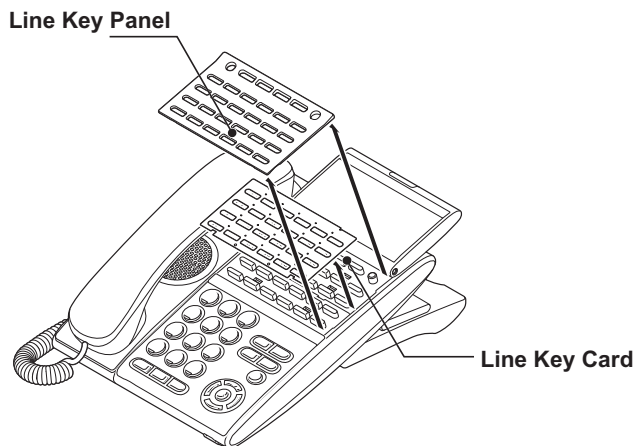

- **TO INSTALL KEY SET UNIT (LINE KEY PANEL, BUTTON PANEL, AND LINE KEY CARD)**

STEP 1: Align the holes in the line key card with the buttons on the telephone.

STEP 2: Align the holes in the line key panel with the buttons on the telephone and then push the four corners of the panel until the panel clicks into place.

Line Key Panel

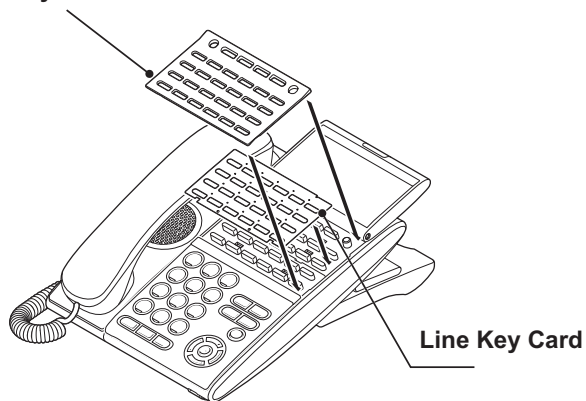

**Note:** Be sure to install the line key panel correctly, or it may cause undesired operation of the terminal.

## WALL MOUNTING **DT830** **DT430/410**

A wall mount unit (WM-L UNIT) is used to mount all telephones to the wall. This unit connects to the back side of the telephone.

	<p><b>WARNING</b> Be careful not to drop the telephone set while mounting it on the wall. It can cause injury. Make sure the telephone set is firmly mounted on the wall to prevent the telephone set from falling out. It can cause injury.</p>
---	--

To mount the telephone set on the wall, the following space is required.

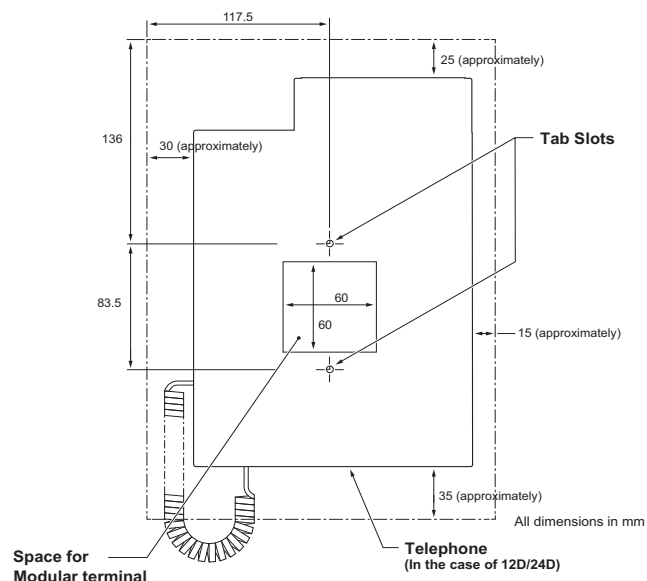

To mount the telephone set on the wall, use the following procedure.

**STEP 1:** Mount the hanger of the handset upside down.

Remove the hanger from the handset once. Turn it upside down and then insert the hanger until you hear it clicks.

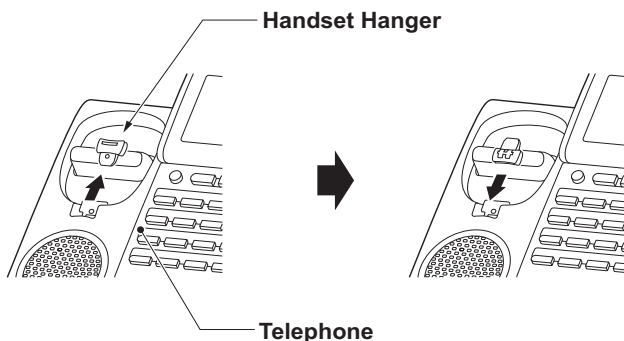

**STEP 2:** Turn the telephone set upside down and widen the tilt leg.

**STEP 3:** Attach WM-L UNIT to the wall directly or the wall plate.

- When attaching WM-L UNIT to the wall directly:

Secure WM-L UNIT with the six screws (included with the telephone set) or hang WM-L UNIT on the wall with the two screws (purchased separately) inserted into the wall.

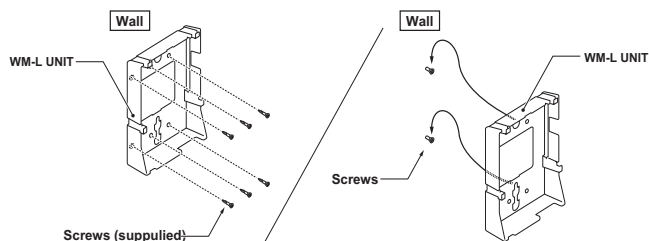

- When attaching WM-L UNIT to the wall plate:  
Attach WM-L UNIT to the posts on the wall plate as shown in the figure below.

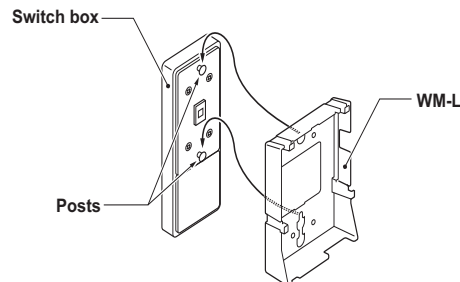

The remainder of the procedure varies between DT430 Series and DT830 Series.

- In the case of DT430 Series: Go to the next step.
- In the case of DT830 Series: Go to Step 8 after the LAN cable is connected to the telephone.

**STEP 4:** Attach the modular terminal to the wall as shown in the following figure. If the modular



connector is attached directly on the wall or the wall plate is used instead of modular terminal, skip this step.

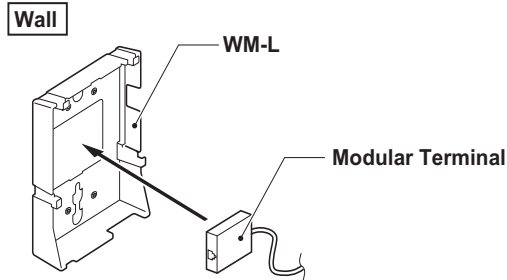

STEP 5: Insert the line cord plug (included with the telephone set) into the modular connector.

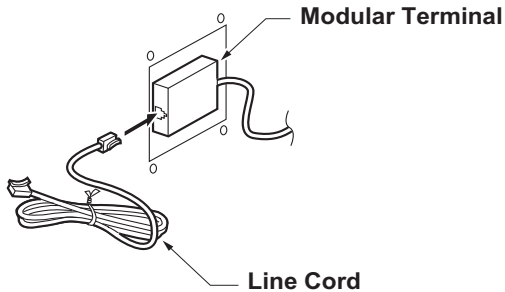

STEP 6: Insert the line cord plug into the LINE connector on the back of the telephone. Wrap the excess cord and secure it with a tie wrap.

STEP 7: Fit the coiled cord through the groove on the back of the telephone as shown in the figure below.

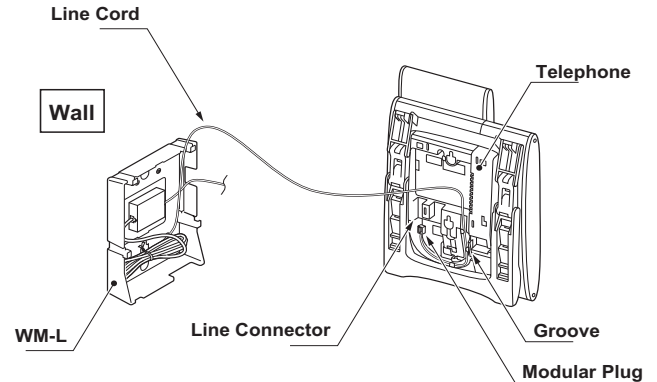

STEP 8: Insert the four tabs on WM-L UNIT in the tab slots on the back of the telephone.

Tuck the excess cord into WM-L UNIT.

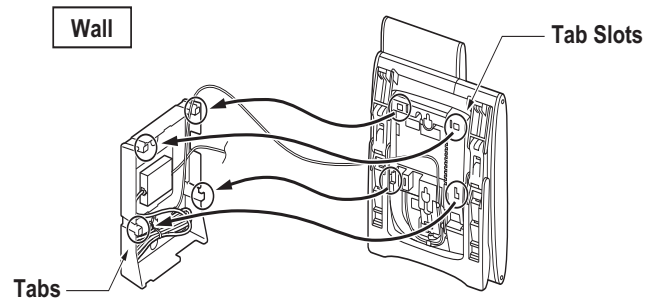

# 3. TERMINAL SETUP

This chapter describes operating procedures for terminal settings with the **Up/Down** (📞) key, **Feature** key and **Menu** key.

Various terminal settings such as display, sounds, password, and language are also available from **Menu** key.

## SETUP WITH UP/DOWN KEY

- **TO ADJUST HANDSET RECEIVER VOLUME** **DT830** **DT430/410**

Press the **Up/Down** (📞) key in the off-hook status or during the call.

LCD indication for North America, Latin America, Asia, Middle East and Russia



LCD indication for Australia



- **TO ADJUST SPEAKER VOLUME** **DT830** **DT430/410**

Press the **Up/Down** (📞) key during an speaker phone operation or during the call.

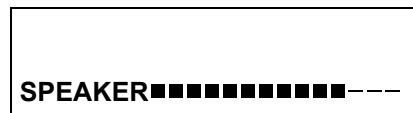

- **TO ADJUST RINGER TONE** **DT830** **DT430/410**

Press the **Up/Down** (📞) key while the terminal is ringing.

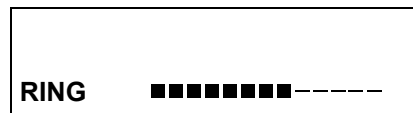

- **TO ADJUST LCD CONTRAST**

**DT830 DT430/410**

Press the Up/Down (Ⓜ) key in the on-hook status.



For DT830 Series, an adjustment range of the LCD contrast is available in 2 types (Wide/Narrow). The type of adjustment range depends on the configuration setting.

**Wide Setting**



**Narrow Setting**



**Note:** For the details of configuration setting, please contact the system administrator.

## SETUP WITH FEATURE KEY

- **MICROPHONE ON/OFF** **DT830**

**DT430/410**

LED on **Mic** key shows the status of the built-in microphone.

STEP 1: Press the soft key associated with the Mic on the LCD or press **Feature** and **1** key.

- **TO CHANGE THE HANDSET RECEIVER VOLUME** **DT430/410**

The handset receiver volume can be changed.

STEP 1: Press **Feature** and **2** key. The LCD displays the current volume status.

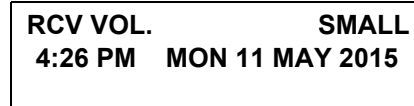

STEP 2: Press **Feature** and **2** key to alternate between Large and Small volume.



- **TO SELECT RINGER TONE** **DT430/410**

The terminal have 10 kinds of ringer tones that you can select.

STEP 1: Press **Feature** and **3** key. The LCD displays the selected tone number (n=1 ~ 10).

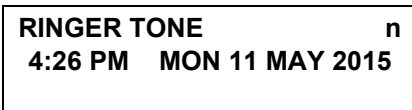

No.	Frequency (Hz)	Modulation (Hz)
1	520/660	16
2	520/660	8
3	1100/1400	16
4	660/760	16
5	Melody 1	
6	Melody 2	
7	Melody 3	
8	Melody 4	
9	Melody 5	
10	Melody 6	

**Note:** The tone number 5, 6, and 8~10 (**Melody 1, 2, 4~6**) sound continuously.

- **TO ADJUST TRANSMISSION/RECEIVING VOLUME** **DT430/410**

The handset volume can be changed.

STEP 1: Press **Feature** and **4** key. The LCD displays the current volume.

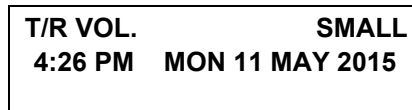

STEP 2: Press **Feature** and **4** key again to alternate between Large and Small volume.

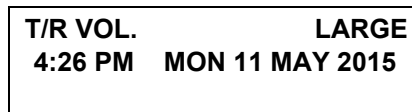

- **TO ACTIVATE HANDS-FREE** **DT430/410**

To Set hands-free On:

STEP 1: Press **Feature** and **5** key.  
The LCD displays:

<b>HANDS FREE</b>	<b>ON</b>
<b>4:26 PM</b>	<b>MON 11 MAY 2015</b>

To Set hands-free Off:

STEP 1: Press **Feature** and **6** key. The LCD displays:

<b>HANDS FREE</b>	<b>OFF</b>
<b>4:26 PM</b>	<b>MON 11 MAY 2015</b>

- **CALL INDICATOR LAMP ON/OFF**

**DT830** **DT430/410**

You can choose to turn the call indicator lamp either on or off during the call.

STEP 1: Press **Feature** and **7** key. The LCD displays:

<b>INDICATOR</b>	<b>ON</b>
<b>4:26 PM</b>	<b>MON 11 MAY 2015</b>
<b>INDICATOR</b>	<b>OFF</b>
<b>4:26 PM</b>	<b>MON 11 MAY 2015</b>

**Note:** The call indicator lamp lights when used as a Message Waiting Lamp, even when it is turned off by the above operation.

- **SELECT DIAL MODE**

**DT830** **DT430/410**

You can select one pattern from Normal, Dynamic Dial Pad or Preset Dial to originate a call.

**When only Dynamic Dial Pad is activated:**

To Set/Reset Dynamic Dial Pad

STEP 1: Press **Feature** and **8** key. The LCD displays:

<b>Direct Dial Pad</b>	<b>ON</b>
<b>4:26 PM</b>	<b>MON 11 MAY 2015</b>
<b>Direct Dial Pad</b>	<b>OFF</b>
<b>4:26 PM</b>	<b>MON 11 MAY 2015</b>

**Note:** When this feature is ON, you may initiate a call by immediately dialing the number and the station will go hands-free off-hook automatically. For details, see [TO ORIGINATE A CALL USING SELECTIVE DIALING \(DYNAMIC DIAL PAD, PRESET DIAL\)](#).

When only Preset Dial is activated:

To Set/Reset Preset Dial

STEP 1: Press **Feature** and **8** key. The LCD displays:

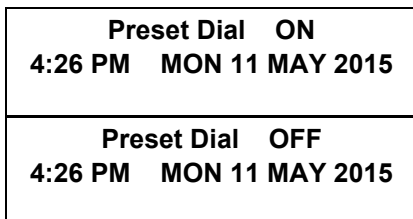

**Note:** When this feature is ON, you may initiate a call by pressing the **Speaker** key or going off-hook after dialing the number. For details, see [TO ORIGINATE A CALL USING SELECTIVE DIALING \(DYNAMIC DIAL PAD, PRESET DIAL\)](#)

When both Dynamic Dial Pad and Preset Dial are activated:

To Set Dial Mode

STEP 1: Every time **Feature** and **8** key are pressed, the Dial Mode switches. The LCD displays:

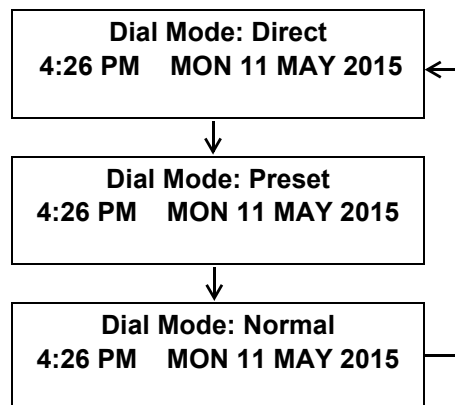

## SETUP WITH MENU KEY FOR DT830 SERIES



### • TO ENABLE/DISABLE OFF-HOOK RINGING

The procedure below shows how to enable/disable Off-hook ringing

STEP 1: Display the **Menu** screen, and select **Setting**.

STEP 2: Select **1** **User Setting**.

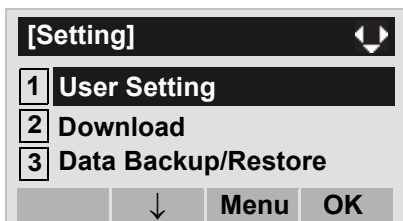

Select an item by either of the following operations.

- Highlight an item by using  or the **UP/DOWN** soft key, and then press ,  or the **OK** soft key.
- Press **1** key.



STEP 3: Select **1** **Incoming Call**.

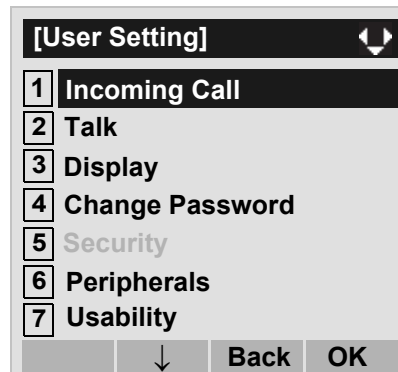

Select an item by either of the following operations.

- Highlight an item by using  or the **UP/DOWN** soft key, and then press ,  or the **OK** soft key.
- Press **1** key.



STEP 4: Select **2** **Offhook Ring**

Select an item by either of the following operations.



- Highlight an item by using  or the **UP/DOWN** soft key, and then press ,  or the **OK** soft key.
- Press **2** key



STEP 5: To disable/enable the off-hook ringing, select

**1** Disable or **2** Enable.

Select an item by one of the following operations.

- Highlight an item by using  or the **UP/DOWN** soft key, and then press  or the **OK** soft key.
- Press **1** or **2** key, and then press  or the **OK** soft key.



**Note:** Default setting is **2** Enable.

**Note:** The enabled item is highlighted.



## • TO SET RINGING OF HEADSET

The procedure below shows how to enable/disable the ringing of headset.

STEP 1: Display the **Menu** screen, and select **Setting**.

STEP 2: Select **1** User Setting.

Select an item by either of the following operations.

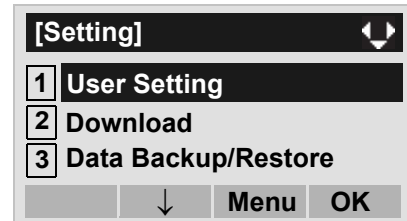

- Highlight an item by using  or the **UP/DOWN** soft key, and then press ,  or the **OK** soft key.
- Press **1** key.





**STEP 3: Select [1] Incoming Call.**

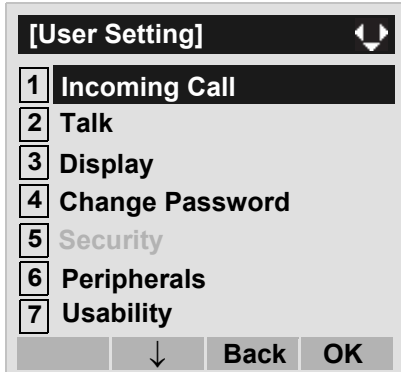

Select an item by either of the following operations.

- Highlight an item by using  or the **UP/DOWN** soft key, and then press  or the **OK** soft key.
- Press **(1)** key.



**STEP 4: Select [3] Headset Ring.**

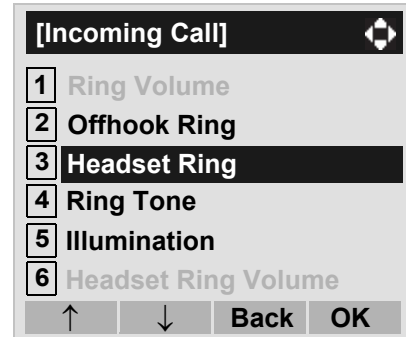

Select an item by either of the following operations.

- Highlight an item by using  or the **UP/DOWN** soft key, and then press  or the **OK** soft key.
- Press **(3)** key.



**STEP 5: To disable/enable the ringing of headset, select [1] Disable or [2] Enable.**

Select an item by one of the following operations.

- Highlight an item by using  or the **UP/DOWN** soft key, and then press  or the **OK** soft key.
- Press **(1)** or **(2)** key, and then press  or the **OK** soft key.



**Note:** Default setting is **[1] Disable**.

**Note:** The enabled item is highlighted.



## • TO SET RINGER TONE

The procedure below shows how to change the ringer tone for internal call and external call.

STEP 1: Display the **Menu** screen, and select **Setting**.

STEP 2: Select **1 User Setting**.

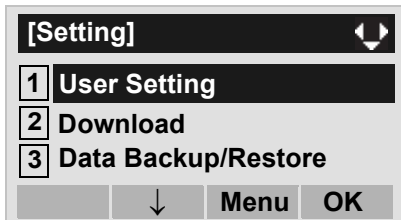

Select an item by either of the following operations.

- Highlight an item by using  or the **UP/DOWN** soft key, and then press  or the **OK** soft key.
- Press **1** key.



STEP 3: Select **1 Incoming Call**.

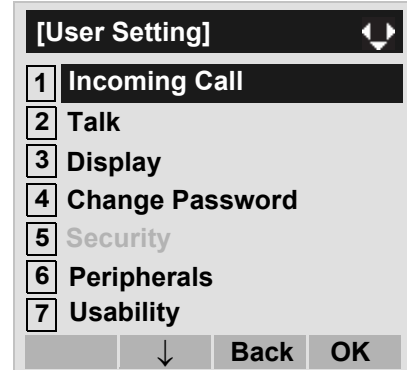

Select an item by either of the following operations.

- Highlight an item by using  or the **UP/DOWN** soft key, and then press  or the **OK** soft key.
- Press **1** key.



STEP 4: Select **4 Ring Tone**

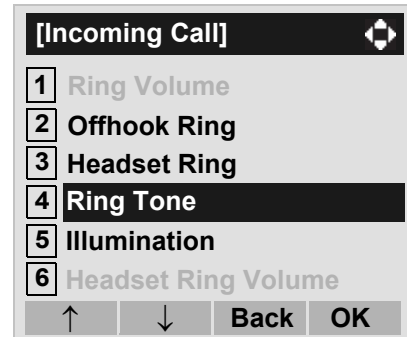

Select an item by either of the following operations.

- Highlight an item by using  or the **UP/DOWN** soft key, and then press  or the **OK** soft key.
- Press **4** key.



STEP 5: Select **1 External Call** when setting the ringer tone for external calls. Select **2 Internal Call** when setting the ringer tone for internal calls.



Select an item by either of the following operations.

- Highlight an item by using  or the **UP/DOWN** soft key, and then press  or the **OK** soft key.
- Press **1** or **2** key.



STEP 6: Select a desired tone type. You can preview the designated ringer tone.

Select an item by either of the following operations.

- Highlight an item by using  or the **UP/DOWN** soft key, and then press  or the **OK** soft key.
- Press **0** - **9** key, and then press  or the **OK** soft key.

For example, press **1** + **5** to select **15 Download1**.

**Note:** The enabled item is highlighted.

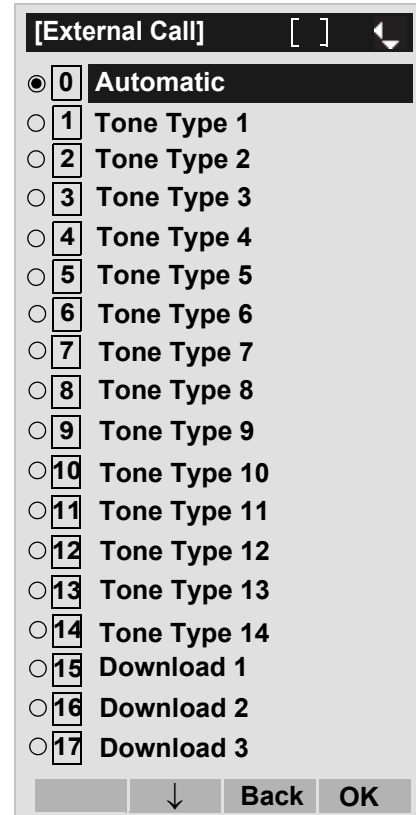

No.	Menu Item	Frequency (Hz)		Remarks
		1st	2nd	
0	Automatic	520	660	16Hz modulation
1	Tone Type 1	520	660	16Hz modulation
2	Tone Type 2	520	660	8Hz modulation
3	Tone Type 3	1400	1100	Door Phone
4	Tone Type 4	1100		No modulation
5	Tone Type 5	540		No modulation
6	Tone Type 6	1100	1400	16Hz modulation
7	Tone Type 7	660	760	16Hz modulation
8	Tone Type 8	1100		Envelope
9	Tone Type 9	-		Door Phone Melody
10	Tone Type 10	-		Melody 1
11	Tone Type 11	-		Melody 2
12	Tone Type 12	-		Melody 3
13	Tone Type 13	-		Melody 4
14	Tone Type 14	-		Melody 5
15	Download 1	-		DT830 only
16	Download 2	-		DT830 only
17	Download 3	-		DT830 only

**Note:** When selecting **Automatic** or not performing this ringer tone setting, **Tone Type 1** is automatically applied.

**Note:** When selecting **Automatic**, the preview function will not operate. Also, when selecting **Download 1/2/3**, the ringer tone file must be downloaded in advance. If there is no downloaded file, you hear no tone.

**Note: Tone Type 1 to Tone Type 8:**

In the preview function, each ringer tone sounds continuously. Actual ringer pattern of each tone is determined by the initial system settings.

**Note:** Terminal settings may not become effective, according as the system settings. For details, contact the System administrator.

**Note:** You can set ringer tone for the telephone set here. Ringer Tone type can be set for "Name", "Group" and "Telephone set". The ringer Tone type set for "Name" has higher priority than the types set for "Group" and "Terminal set".



## • TO SET ILLUMINATION PATTERN FOR CALL INDICATION LAMP

The procedure below shows how to set the illumination pattern (color of Call Indicator Lamp).

STEP 1: Display the **Menu** screen, and select **Setting**.

STEP 2: Select **1 User Setting**.

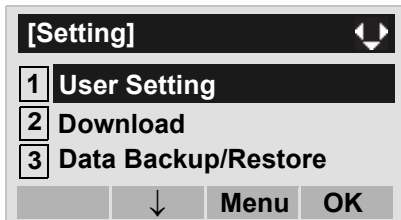

Select an item by either of the following operations.

- Highlight an item by using  or the **UP/DOWN** soft key, and then press ,  or the **OK** soft key.
- Press **1** key.



STEP 3: Select **1 Incoming Call**.

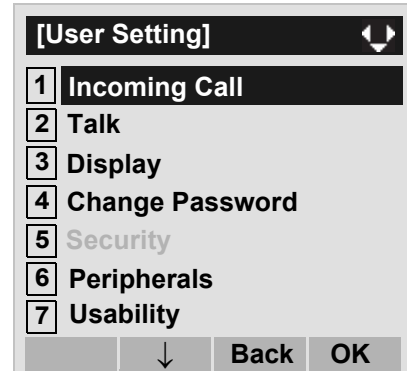

Select an item by either of the following operations.

- Highlight an item by using  or the **UP/DOWN** soft key, and then press ,  or the **OK** soft key.
- Press **1** key.



STEP 4: Select **5 Illumination**.



Select an item by either of the following operations.

- Highlight an item by using  or the **UP/DOWN** soft key, and then press ,  or the **OK** soft key.
- Press **5** key.



STEP 5: Select **1 External Call** when setting the illumination pattern for external calls. Select **2 Internal Call** when setting the illumination pattern for internal call.

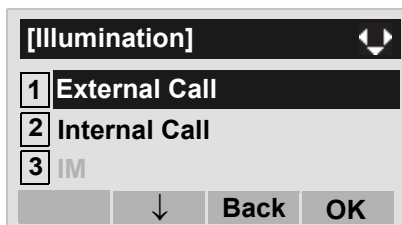

Select an item by one of the following operations.

- Highlight an item by using  or the **UP/DOWN** soft key, and then press ,  or the **OK** soft key.
- Press **1** or **2** key.



STEP 6: Select a desired illumination pattern. You can preview the designated illumination pattern.

Select an item by either of the following operations.

- Highlight an item by using  or the **UP/DOWN** soft key, and then press  or the **OK** soft key.
- Press **0** - **9** key.

- For DT830 Series

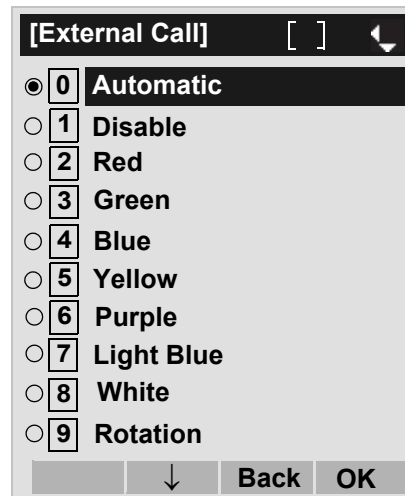

**Note:** When selecting **Automatic**, the preview function will not operate.

**Note:** When selecting **Automatic** or not performing this illumination setting, **Red** is automatically applied.

**Note:** You can set illumination pattern for the telephone set here. Illumination pattern can be set for “Name”, “Group” and “Telephone set”. The illumination pattern set for “Name” has higher priority than the patterns set for “Group” and “Terminal set”.



## • TO ENABLE/DISABLE RTP ALARM

The procedure below shows how to enable/disable RTP alarm.

STEP 1: Display the **Menu** screen, and select **Setting**.

STEP 2: Select **1 User Setting**.

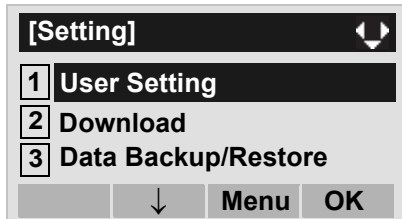

Select an item by either of the following operations.

- Highlight an item by using  or the **UP/DOWN** soft key, and then press  or the **OK** soft key.
- Press **1** key.



STEP 3: Select **2 Talk**.

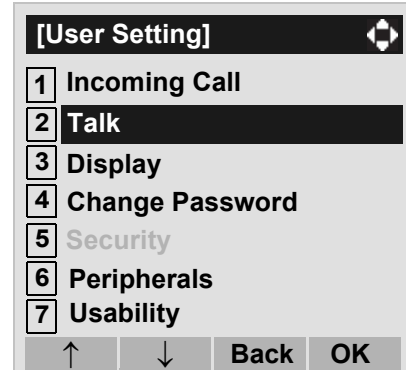

Select an item by either of the following operations.

- Highlight an item by using  or the **UP/DOWN** soft key, and then press  or the **OK** soft key.
- Press **2** key.



STEP 4: Select **1 RTP Alarm**.

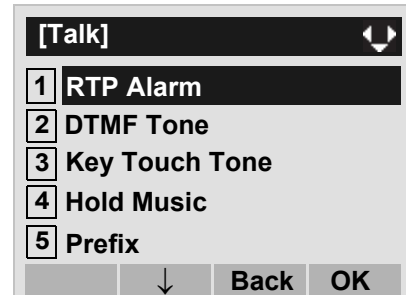

Select an item by either of the following operations.

- Highlight an item by using  or the **UP/DOWN** soft key, and then press  or the **OK** soft key.
- Press **1** key.



STEP 5: Select **0 Automatic**, **1 Disable** or **2 Enable** (see the following table).

Select an item by either of the following operations.

- Highlight an item by using  or the **UP/DOWN** soft key, and then press  or the **OK** soft key.
- Press **0** - **2** key, and then press  or the **OK** soft key.

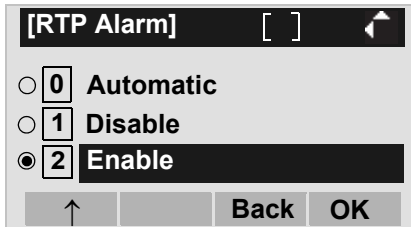

No.	Menu Items	Descriptions
0	Automatic	Follow the setting on the System. If no setting is made in the System, the default setting (Alarm=ON) is applied.
1	Disable	Follow the setting on the terminal (OFF).
2	Enable	Follow the setting on the terminal (ON).

**Note:** For the setting on the System, contact the System administrator.

**Note:** The enabled item is highlighted.



## • TO ENABLE/DISABLE DTMF TONE

The procedure below shows how to enable/disable DTMF Tone.

STEP 1: Display the **Menu** screen, and select **Setting**.

STEP 2: Select **1 User Setting**.

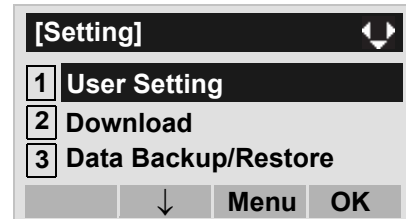

Select an item by either of the following operations.

- Highlight an item by using  or the **UP/DOWN** soft key, and then press  or the **OK** soft key.
- Press **1** key.



STEP 3: Select **2 Talk**.

Select an item by either of the following operations.

- Highlight an item by using  or the **UP/DOWN** soft key, and then press  or the **OK** soft key.
- Press **2** key.



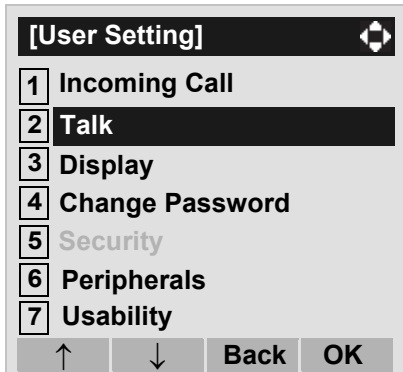

STEP 4: Select **2** DTMF Tone.

Select an item by either of the following operations.

- Highlight an item by using or the **UP/DOWN** soft key, and then press , or the **OK** soft key.
- Press **2** key.



STEP 5: Select **0** Automatic, **1** Disable or **2** Enable (see the following table).

Select an item by either of the following operations.

- Highlight an item by using or the **UP/DOWN** soft key, and then press or the **OK** soft key.
- Press **0** - **2** key, and then press or the **OK** soft key.

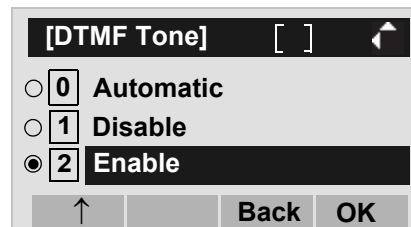

No.	Menu Items	Descriptions
0	Automatic	Follow the setting on the System. If no setting is made in the System, the default setting (DTMF=ON) is applied.
1	Disable	Follow the setting on the terminal (OFF).
2	Enable	Follow the setting on the terminal (ON).

**Note:** For the setting on the System, contact the System administrator.

**Note:** The enabled item is highlighted.



## • TO SET KEY TOUCH TONE

The procedure below shows how to set Key Touch Tone. Key Touch Tone is a tone generated when the digit keys are pressed while the terminal is off-hook.

STEP 1: Display the **Menu** screen, and select **Setting**.

STEP 2: Select **1 User Setting**.

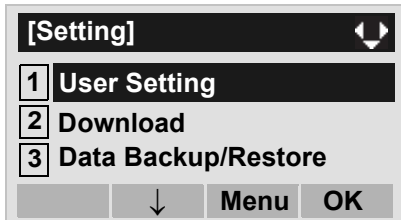

Select an item by either of the following operations.

- Highlight an item by using  or the **UP/DOWN** soft key, and then press ,  or the **OK** soft key.
- Press **1** key.



STEP 3: Select **2 Talk**.

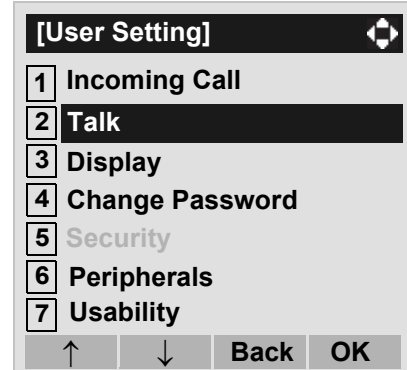

Select an item by either of the following operations.

- Highlight an item by using  or the **UP/DOWN** soft key, and then press ,  or the **OK** soft key.
- Press **2** key.



STEP 4: Select **3 Key Touch Tone**.

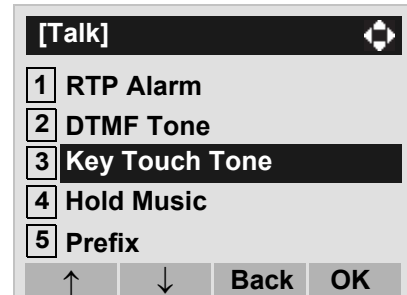

Select an item by either of the following operations.

- Highlight an item by using  or the **UP/DOWN** soft key, and then press ,  or the **OK** soft key.
- Press **3** key.



STEP 5: Select **0 Automatic**, **1 No Tone**, **2 Tone** or **3 Voice**.

Select an item by either of the following operations.

- Highlight an item by using  or the **UP/DOWN** soft key, and then press  or the **OK** soft key.
- Press **0** - **3** key, and then press  or the **OK** soft key.

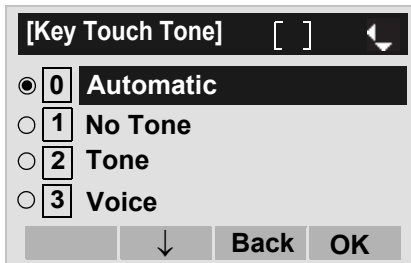

**Note:** When **0 Automatic** is set, the default setting (Tone) is applied.

**Note:** The enabled item is highlighted.



## • TO SET MUSIC ON HOLD

The procedure below shows how to set Music on Hold to be heard by the terminal user.

STEP 1: Display the **Menu** screen, and select **Setting**.

STEP 2: Select **1 User Setting**.

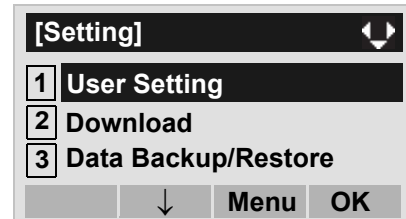

Select an item by either of the following operations.

- Highlight an item by using  or the **UP/DOWN** soft key, and then press  or the **OK** soft key.
- Press **1** key.



STEP 3: Select **2** **Talk**.

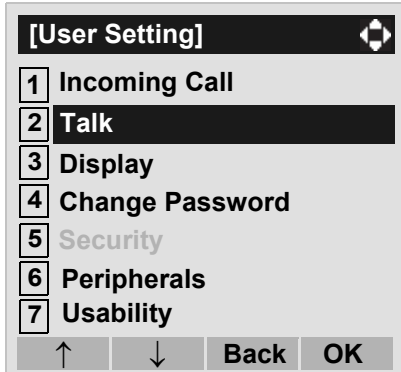

Select an item by either of the following operations.

- Highlight an item by using  or the **UP/DOWN** soft key, and then press  or the **OK** soft key.
- Press **2** key.



STEP 4: Select **4** **Hold Music**.

Select an item by either of the following operations.

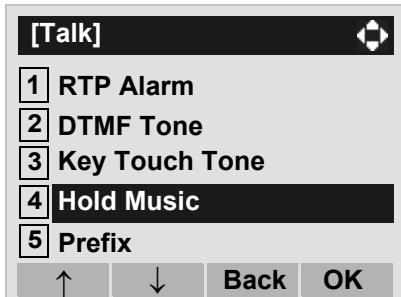

- Highlight an item by using  or the **UP/DOWN** soft key, and then press  or the **OK** soft key.
- Press **4** key.



STEP 5: Select a desired Music on Hold. You can preview the designated Music on Hold.

Select **1** **Default** when the default data (Minuet) is used as Music on Hold. Select **2** **Download** when a downloaded data is used as Music on Hold.

Select an item by either of the following operations.

- Highlight an item by using  or the **UP/DOWN** soft key, and then press  or the **OK** soft key.
- Press **1** or **2** key, and then press  or the **OK** soft key.

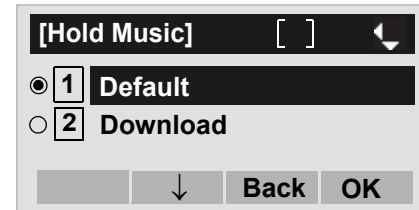

**Note:** When selecting **2 Download**, the music on hold file must be downloaded in advance. If there is no downloaded file, you hear no tone in the preview function (in actual operating conditions, “Minuet” is automatically applied.).

## • TO SET CALENDAR FORMAT

The following explains how to set the time display pattern on the LCD.



**Note:** This setting is available for the following conditions.

- SV9500 V2 or later
- Terminal firmware version 3.0.3.0 or later

STEP 1: Display the **Menu** screen, and select **Setting**.

STEP 2: Select **1 User Setting**.

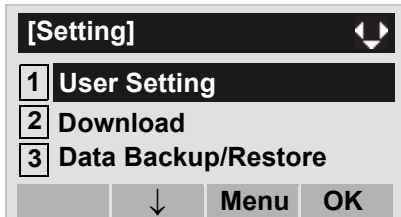

Select an item by either of the following operations.

- Highlight an item by using  or the **UP/DOWN** soft key, and then press  or the **OK** soft key.
- Press **1** key.



STEP 3: Select **3 Display**.

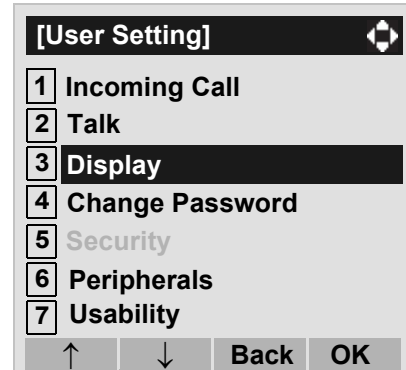

Select an item by either of the following operations.

- Highlight an item by using  or the **UP/DOWN** soft key, and then press  or the **OK** soft key.
- Press **3** key.



STEP 4: Select **1 Calendar Format**.

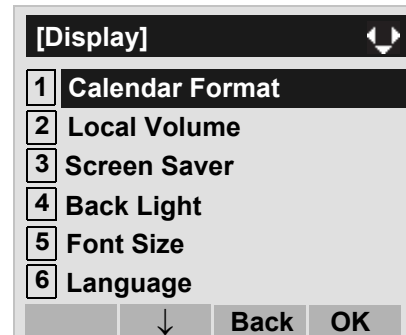

Select an item by either of the following operations.

- Highlight an item by using  or the **UP/DOWN** soft key, and then press  or the **OK** soft key.
- Press **1** key.



**STEP 5: Select 1 Calendar Format.**



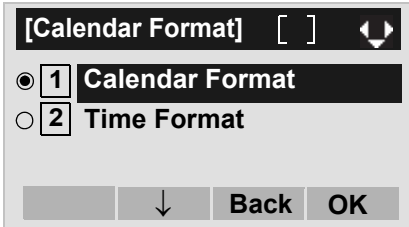

Select an item by either of the following operations.

- Highlight an item by using  or the **UP/DOWN** soft key, and then press ,  or the **OK** soft key.
- Press 1 key.



**STEP 6: Make a selection from the following list.**

Select an item by either of the following operations.

- Highlight an item by using  or the **UP/DOWN** soft key, and then press ,  or the **OK** soft key.
- Press 0 - 5 key, and then press  or the **OK** soft key.

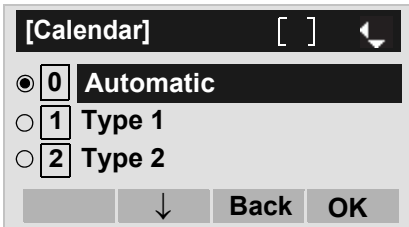

No.	Menu Item	Meaning
5	Type 5	7:25AM MON 23 MAR

**Note:** Default setting is Automatic.

**Note:** The enabled item is highlighted.

No.	Menu Item	Meaning
0	Automatic	Follows the setting on the system
1	Type 1	7:25 AM MON 23 MAR 2015
2	Type 2	23 MAR MON 7:25AM
3	Type 3	7:25AM MAR 23 MON
4	Type 4	3-23 MON 7:25AM

## • TO SET TIME FORMAT



Determines whether time is displayed with a 12-hour or 24-hour clock format.

**Note:** This setting is available for Time Display only. Call Log feature displays the time in 24-hour format regardless of this setting.

STEP 1: Display the **Menu** screen, and select **Setting**.

STEP 2: Select **1** **User Setting**.

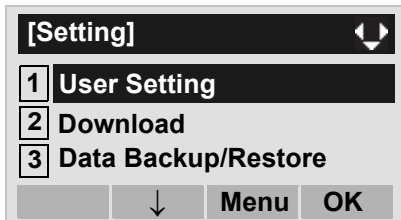

Select an item by either of the following operations.

- Highlight an item by using  or the **UP/DOWN** soft key, and then press  or the **OK** soft key.
- Press **1** key.



STEP 3: Select **3** **Display**.

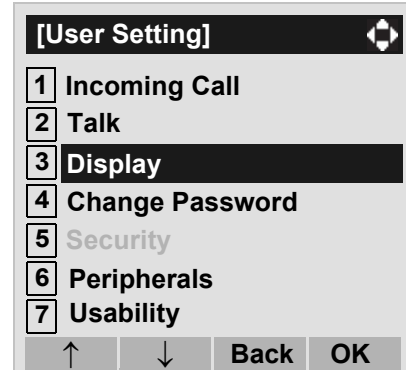

Select an item by either of the following operations.

- Highlight an item by using  or the **UP/DOWN** soft key, and then press  or the **OK** soft key.
- Press **3** key.



STEP 4: Select **1** **Calendar Format**.

Select an item by either of the following operations.

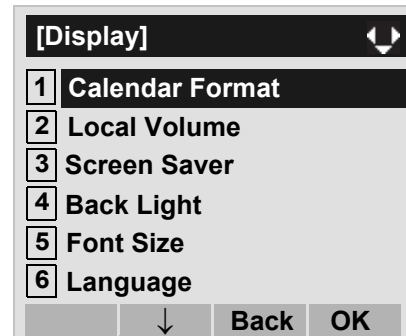

- Highlight an item by using  or the **UP/DOWN** soft key, and then press  or the **OK** soft key.
- Press **1** key.



**Note:** For SV9500 V1, Time Format is displayed instead of Calendar Format. Select Time Format and go to Step 6.

**STEP 5: Select [2] Time Format.**

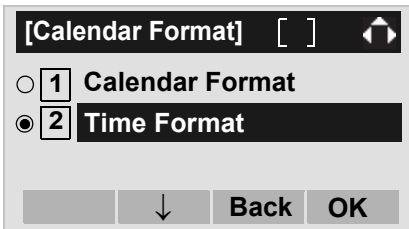

Select an item by either of the following operations.

- Highlight an item by using  or the **UP/DOWN** soft key, and then press ,  or the **OK** soft key.
- Press **[2]** key.



**STEP 6: Make a selection from the following list.**

Select an item by either of the following operations.

- Highlight an item by using  or the **UP/DOWN** soft key, and then press  or the **OK** soft key.
- Press **[0]** - **[2]** key, and then press  or the **OK** soft key.

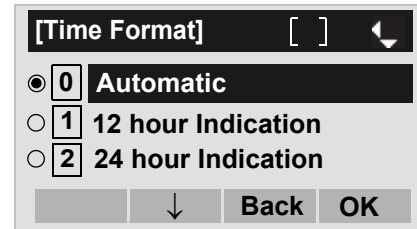

No.	Menu Item	Meaning
0	Automatic	Follows the setting on the system (default)
1	12 hour Indication	12-hour clock
2	24 hour Indication	24-hour clock

**Note:** When selecting Automatic or not performing this time format setting, 12-hour clock is automatically applied.

**Note:** Default setting is Automatic.

**Note:** The enabled item is highlighted.





- **TO ENABLE/DISABLE VOLUME LEVEL DISPLAY**

Determines whether or not to display the following volume levels: handset receiver volume, speaker volume, ringer tone volume and LCD contrast.

STEP 1: Display the **Menu** screen, and select **Setting**.

STEP 2: Select **1 User Setting**.

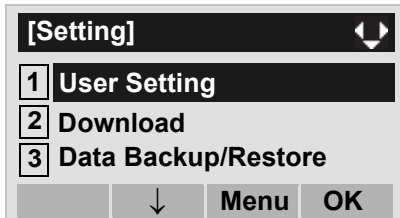

Select an item by one of the following operations.

- Highlight an item by using  or the **UP/DOWN** soft key, and press  or the **OK** soft key.
- Press **1** key.



STEP 3: Select **3 Display**.

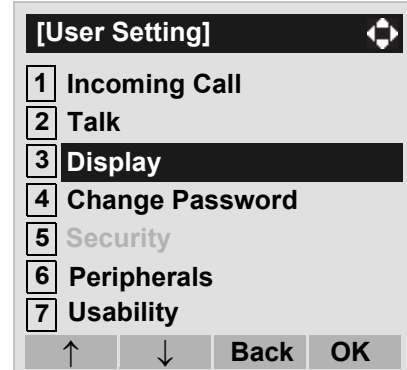

Select an item by either of the following operations.

- Highlight an item by using  or the **UP/DOWN** soft key, and then press  or the **OK** soft key.
- Press **3** key.



STEP 4: Select **2 Local Volume**.

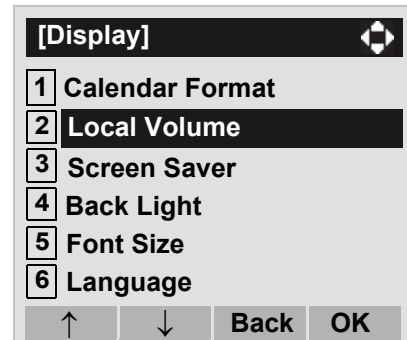

Select an item by either of the following operations.

- Highlight an item by using  or the **UP/DOWN** soft key, and then press  or the **OK** soft key.
- Press **2** key.



STEP 5: Make a selection from the following list.

Select an item by either of the following operations.

- Highlight an item by using  or the **UP/DOWN** soft key, and then press  or the **OK** soft key.
- Press **0** - **2** key, and then press  or the **OK** soft key.

No.	Menu Item	Meaning
0	Automatic	Each volume level is displayed on LCD (default).
1	Disable	Each volume level is not displayed on LCD.
2	Enable	Each volume level is displayed on LCD.

**Note:** The enabled item is highlighted.

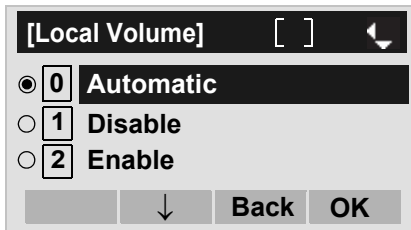

## • TO SET SCREEN SAVER



Screen Saver works after the telephone is in an idle state for a certain period of time. The latest Screen Saver contents will be displayed from XML server when the Screen Saver works. If the latest contents can not be downloaded from XML server, default Screen Saver will be displayed.

**Note:** For details on the XML service, contact the System administrator.

STEP 1: Display the **Menu** screen, and select **Setting**.

STEP 2: Select **1** **User Setting**.

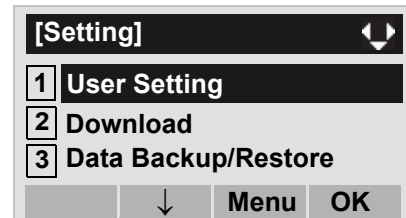

Select an item by either of the following operations.

- Highlight an item by using  or the **UP/DOWN** soft key, and then press ,  or the **OK** soft key.
- Press **1** key.



STEP 3: Select **3** **Display**.

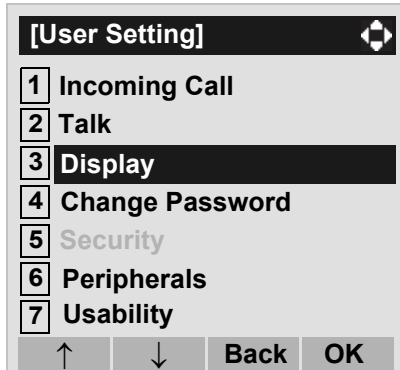

Select an item by either of the following operations.

- Highlight an item by using  or the **UP/DOWN** soft key, and then press ,  or the **OK** soft key.
- Press **3** key.



STEP 4: Select **3** **Screen Saver**.

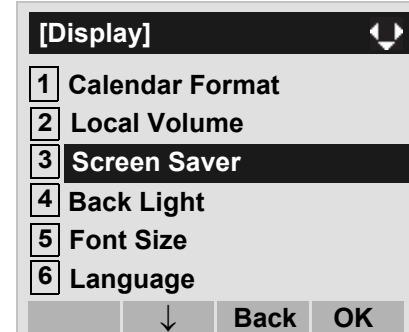

Select an item by either of the following operations.

- Highlight an item by using  or the **UP/DOWN** soft key, and then press ,  or the **OK** soft key.
- Press **3** key.



STEP 5: Select **1** **Screen Saver Mode**.

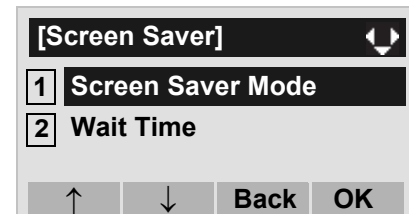

Select an item by either of the following operations.

- Highlight an item by using  or the **UP/DOWN** soft key, and then press ,  or the **OK** soft key.
- Press **1** key.



STEP 6: Select either **1 Disable** or **2 Enable**.

Select an item by one of the following operations.

- Highlight an item by using  or the **UP/DOWN** soft key, and then press  or the **OK** soft key.
- Press **1** or **2** key, and then press  or the **OK** soft key.

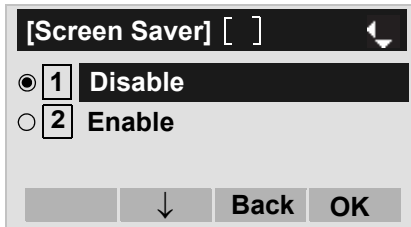

**Note:** Default setting is **1 Disable**.

**Note:** The enabled item is highlighted.

STEP 7: The display goes back to the **Screen Saver** screen. When **2 Enable** is selected on Step 6, Select **2 Wait Time**.

Input **Wait Time** to launch the screen saver (1-999min) and then press  or the **OK** soft key.



**Note:** Default value is 120 min.

## • TO ENABLE/DISABLE BACKLIGHT

The following explains how to enable/disable the backlights of LCD and digit keys.



**Note:** Backlight feature is optional. For DT410 Series, this feature is not supported.

The backlights illuminate (for approximately 10 seconds) when you press any key or lifts the handset.

STEP 1: Display the **Menu** screen, and select **Setting**.

STEP 2: Select **1 User Setting**.

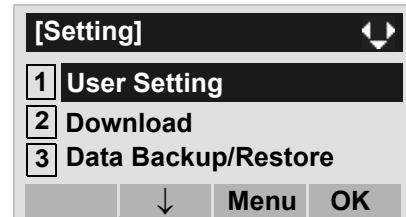

Select an item by either of the following operations.

- Highlight an item by using  or the **UP/DOWN** soft key, and then press ,  or the **OK** soft key.
- Press **1** key.



STEP 3: Select **3 Display**.

Select an item by either of the following operations.

- Highlight an item by using  or the **UP/DOWN** soft key, and then press ,  or the **OK** soft key.
- Press **3** key.

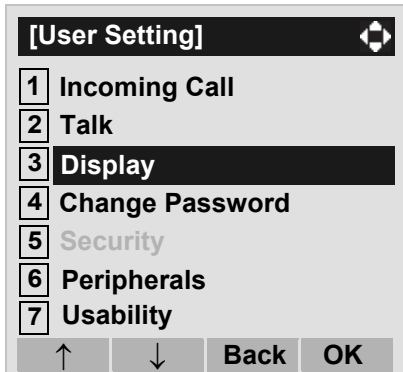

**STEP 4:** Select **4** **Back Light**.

Select an item by either of the following operations.

- Highlight an item by using or the **UP/DOWN** soft key, and then press or the **OK** soft key.
- Press **4** key.

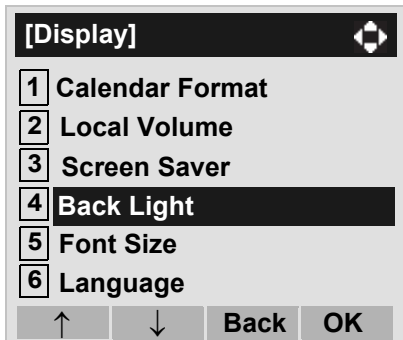

**STEP 5:** Make a selection from the following list.

Select an item by either of the following operations.

- Highlight an item by using or the **UP/DOWN** soft key, and then press or the **OK** soft key.
- Press **1** or **2** key, and then press or the **OK** soft key.

No.	Menu Item	Meaning
1	Disable	Backlights of LCD and digit keys are disabled.
2	Enable	Backlights of LCD and digit keys are enabled.

**Note:** The enabled item is highlighted.

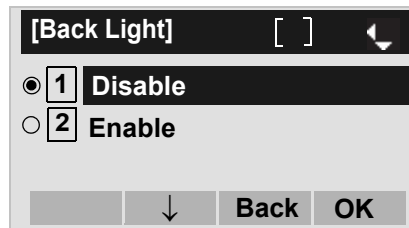



## • TO CHANGE CHARACTER SIZE

The following explains how to change the displayed character size on the LCD.

STEP 1: Display the **Menu** screen, and select **Setting**.

STEP 2: Select **1 User Setting**.

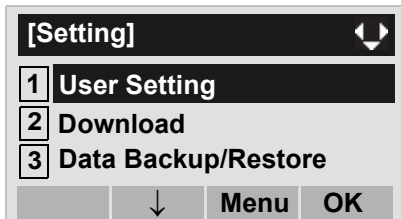

Select an item by either of the following operations.

- Highlight an item by using  or the **UP/DOWN** soft key, and then press  or the **OK** soft key.
- Press **1** key.



STEP 3: Select **3 Display**.

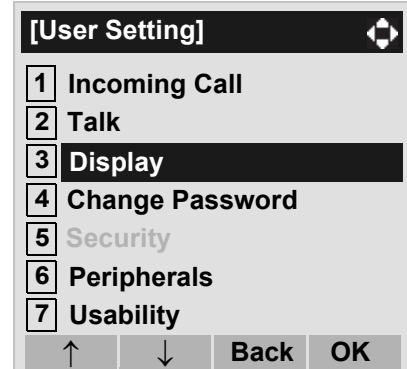

Select an item by either of the following operations.

- Highlight an item by using  or the **UP/DOWN** soft key, and then press  or the **OK** soft key.
- Press **3** key.



STEP 4: Select **5 Font Size**.

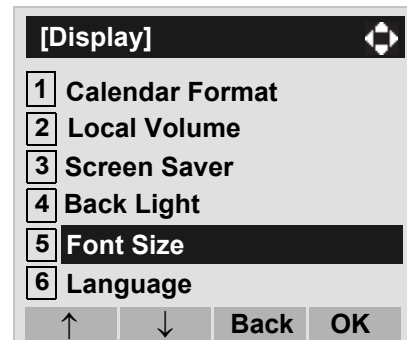

Select an item by either of the following operations.

- Highlight an item by using  or the **UP/DOWN** soft key, and then press  or the **OK** soft key.
- Press **5** key.



STEP 5: Select either “Standard (16dot)” or “Small (12dot)”.

Select an item by either of the following operations.

- Highlight an item by using  or the **UP/DOWN** soft key, and then press  or the **OK** soft key.
- Press **1** or **2** key, and then press  or the **OK** soft key.



**Note:** The enabled item is highlighted.



## • TO SET A LANGUAGE

The following explains how to set a language to be displayed on LCD.

STEP 1: Display the **Menu** screen, and select **Setting**.

STEP 2: Select **1 User Setting**.

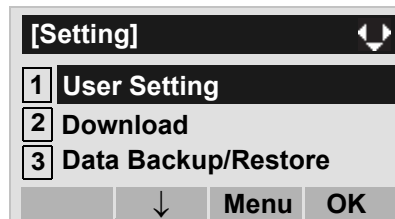

Select an item by either of the following operations.

- Highlight an item by using  or the **UP/DOWN** soft key, and then press ,  or the **OK** soft key.
- Press **1** key.



### STEP 3: Select **3** Display.



Select an item by either of the following operations.

- Highlight an item by using  or the **UP/DOWN** soft key, and then press  or the **OK** soft key.
- Press **3** key.



### STEP 4: Select **6** Language

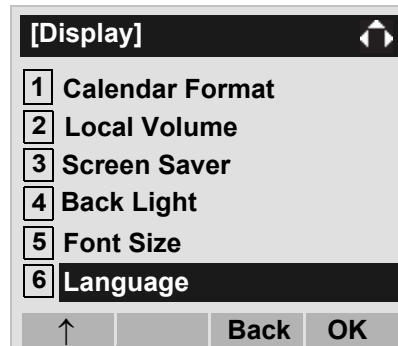

Select an item by either of the following operations.

- Highlight an item by using  or the **UP/DOWN** soft key, and then press ,  or the **OK** soft key.
- Press **6** key (DT830).



### STEP 5: Select a desired language.

Select an item by either of the following operations.

- Highlight an item by using  or the **UP/DOWN** soft key, and then press  or the **OK** soft key.
- Press **0** - **9** key, and then press  or the **OK** soft key.

For example, press **1** + **3** to select **13** English.



**Note:** The enabled item is highlighted.

**Note:** Each item is displayed in its native language as follows:



- |      |               |  |
|------|---------------|--|
| ● 0  | Automatic     | 0:Telephony Server side's language setting is applied. |
| ○ 1  | 日本語           | 1:Japanese   |
| ○ 2  | NEC English   | 2:NEC English  |
| ○ 3  | NEC Português | 3:NEC Portuguese                                       |
| ○ 4  | NEC Español   | 4:NEC Spanish  |
| ○ 5  | NEC Français  | 5:NEC French   |
| ○ 6  | Deutsch       | 6:German   |
| ○ 7  | ITALIANO      | 7:Italian  |
| ○ 8  | Nederlands    | 8:Dutch  |
| ○ 9  | Norsk         | 9:Norwegian  |
| ○ 10 | Dansk         | 10:Danish  |
| ○ 11 | Svensk        | 11:Swedish   |
| ○ 12 | Ελληνικά      | 12:Greek   |
| ○ 13 | English       | 13:English   |
| ○ 14 | Português     | 14:Portuguese  |
| ○ 15 | Español       | 15:Spanish   |
| ○ 16 | Français      | 16:French  |
| ○ 17 | Русский       | 17:Russian   |
| ○ 18 | Türk          | 18:Turkish   |
| ○ 19 | Român         | 19:Romania   |
| ○ 20 | Polski        | 20:Polish  |
| ○ 21 | Català        | 21:Catalan   |
| ○ 22 | 한국어           | 22:Korean  |
| ○ 23 | 中文(簡体字)       | 23:Simplified Chinese                                  |
| ○ 24 | 中文(繁体字)       | 24:Traditional Chinese                                 |

**Note:** “23. Simplified Chinese” and “24. Traditional Chinese” are available since SV9500 V3, and the terminal firmware version 4.0.0.0 or later.

STEP 6: After making a selection, press  or the **OK** soft key.

## • TO CHANGE PASSWORD

To change an existing password, follow the procedure below. This password is used for the following occasions.



- To lock/unlock the telephone.
- To delete the directory data.
- To reset the telephone settings.

**Note:** Depending on the System Configuration, the expiration date of password can be specified. For details, please contact the system administrator.

STEP 1: Display the **Menu** screen, and select **Setting**.

STEP 2: Select **1 User Setting**.

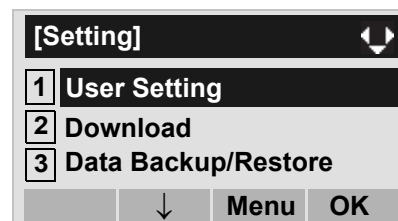

Select an item by either of the following operations.

- Highlight an item by using  or the **UP/DOWN** soft key, and then press ,  or the **OK** soft key.
- Press **1** key.



**STEP 3: Select [4] Change Password.**

Select an item by either of the following operations.

- Highlight an item by using  or the **UP/DOWN** soft key, and then press ,  or the **OK** soft key.
- Press **[4]** key.

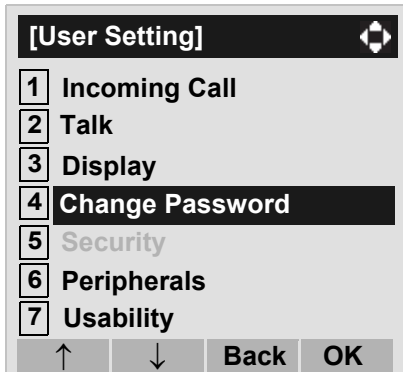

**STEP 4: The Change Password screen is displayed.**

Enter the old password and then press  or the **Set** soft key.

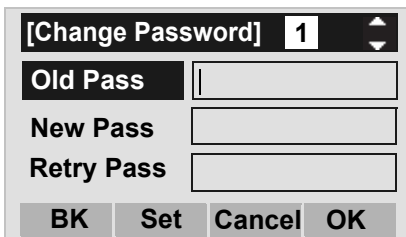

**Note:** The initial password is "0000". When changing the password for the first time, enter "0000" as the old password.

**STEP 5: Enter the new password and then press  or the Set soft key.**

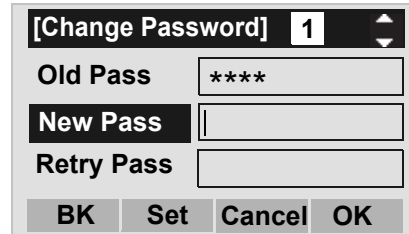

**STEP 6: Enter the new password again and then press  or the OK soft key.**

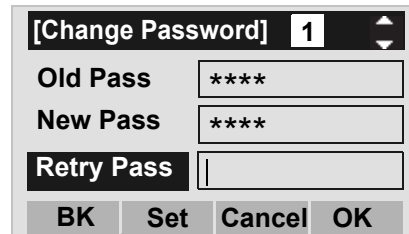

**Note:** A maximum of 32 digits (0-9, \* and #) can be set as a password.

STEP 7: When the password entry completes successfully, the display changes as follows. Press  or the **OK** soft key.

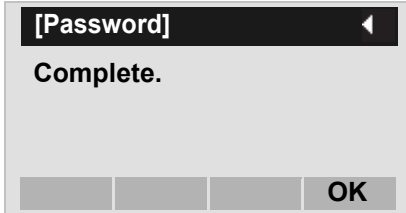

**Note:** When the password entry ends in failure, the following error message is issued. In that case, press the **OK** soft key and try again.

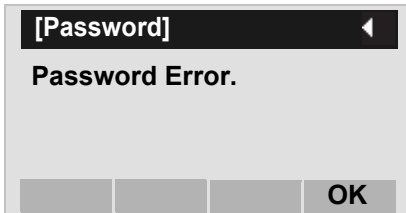

**Note:** When you enter the current password to the **New Pass**, the following error message is issued. In that case, press the **OK** soft key and enter the password except for the current password.

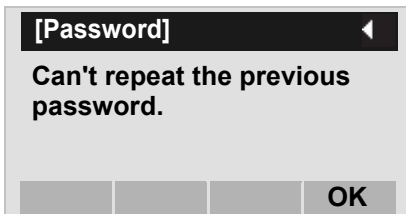



## • TO SET USABILITY

The procedure below shows how to set the operation of the **Help** key while pop-up window is displayed.

STEP 1: Display the **Menu** screen, and select **Setting**.

STEP 2: Select **1 User Setting**.

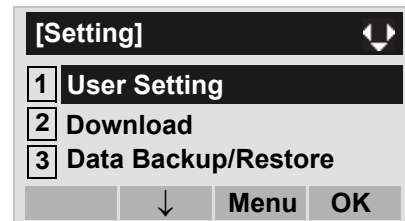

Select an item by one of the following operations.

- Touch panel operation.
- Highlight an item by using  or the **UP/DOWN** soft key, and press ,  or the **OK** soft key.
- Press **1** key.



STEP 3: Select **7 Usability**.

Select an item by one of the following operations.

- Touch panel operation.
- Highlight an item by using  or the **UP/DOWN** soft key, and press ,  or the **OK** soft key.
- Press **7** key.

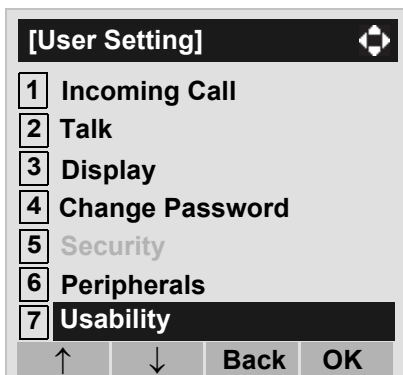

STEP 4: Select **1 Help Key Mode**.



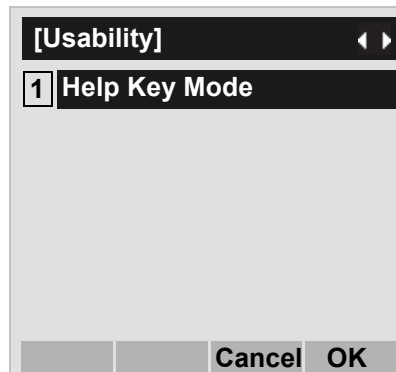

Select an item by one of the following operations.

- Touch panel operation.
- Press  or the **OK** soft key.
- Press **1** key.



**STEP 5: Select a desired mode of Help key.**

Select an item by one of the following operations.

- Touch panel operation, and press  or the **OK** soft key.
- Highlight an item by using  or the **UP/DOWN** soft key, and press  or the **OK** soft key.
- Press **1** or **2** key, and press  or the **OK** soft key.

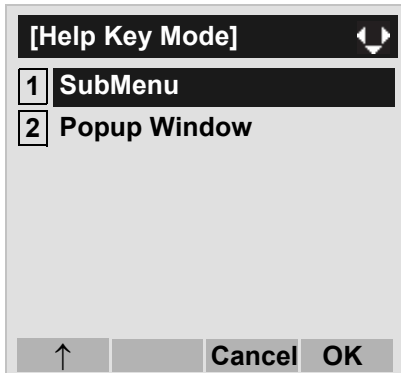

No.	ITEM	DESCRIPTION
1	Sub Menu	Set the Help key which displays sub menu
2	Popup Window	Set the Help key which displays pop-up window



**• TO RESET TELEPHONE SETTINGS**

The following explains how to clear the personal data off the telephone.

**STEP 1: Display the Menu screen, and select Setting.**

**STEP 2: Select 1 User Setting.**



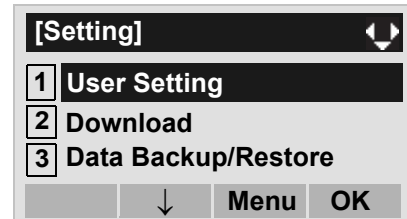

Select an item by either of the following operations.

- Highlight an item by using  or the **UP/DOWN** soft key, and then press   or the **OK** soft key.
- Press **1** key.



**STEP 3: Select [0] Setting Reset.**

Select an item by either of the following operations.

- Highlight an item by using  or the **UP/DOWN** soft key, and then press ,  or the **OK** soft key.
- Press  key.

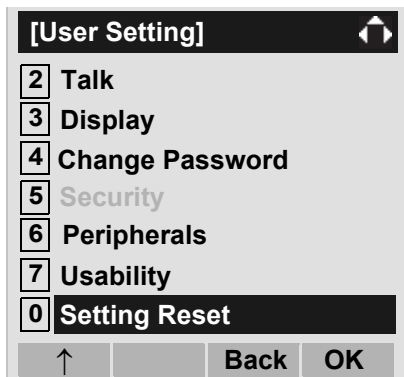

**STEP 4: Enter the password and then press  or the **OK** soft key.**

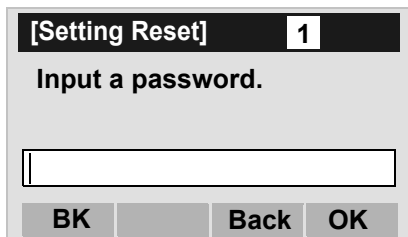

**STEP 5: Press  or the **OK** soft key to clear the personal data of the telephone.**

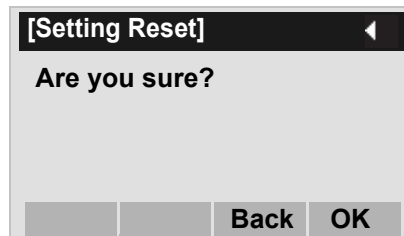

## • TO DOWNLOAD A FILE

The DT830 Series user can download files for Music on Hold, Ringer Tone and Directory. When downloading these files, the terminal needs to be connected FTP/TFTP server.

**Note:** For details on the FTP/TFTP service, contact the System administrator.

Before starting the download, the IP Address of the FTP/TFTP Server must be entered from the terminal.

STEP 1: Set up the FTP/TFTP server.

<FTP server>

Put the downloading file into the designated directory (for Windows IIS, the default is "C:\InetPub\ftproot") of the FTP server.



<TFTP server>

Put the downloading file into a desired directory of TFTP server and then specify it as the directory for downloading.

STEP 2: Display the **Menu** screen, and select **Setting**.

STEP 3: Select **2** **Download**.

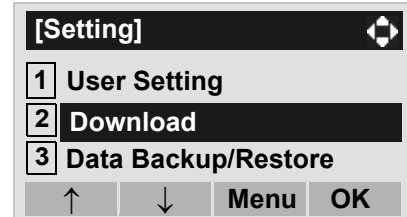

Select an item by either of the following operations.

- Highlight an item by using  or the **UP/DOWN** soft key, and then press ,  or the **OK** soft key.
- Press **2** key.



STEP 4: Select **3** **Protocol**.

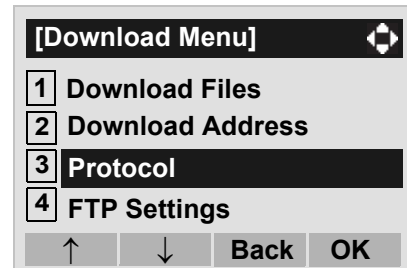

Select an item by either of the following operations.

- Highlight an item by using  or the **UP/DOWN** soft key, and then press ,  or the **OK** soft key.
- Press **3** key.



STEP 5: Select a protocol used by the server which stores the download file.

Select an item by either of the following operations.

- Highlight an item by using  or the **UP/DOWN** soft key, and then press  or the **OK** soft key.
- Press **1** or **2** key, and then press  or the **OK** soft key.

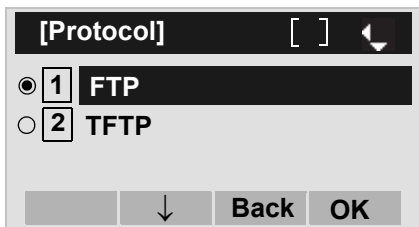



STEP 6: The display goes back to the **Download Menu** screen.

When **1 FTP** is selected here, go to STEP 7.

When **2 TFTP** is selected here, go to STEP 15.

STEP 7: Select **4 FTP Settings**.

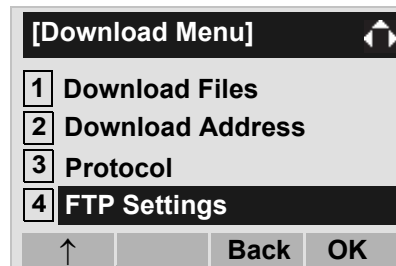

Select an item by either of the following operations.

- Highlight an item by using  or the **UP/DOWN** soft key, and then press  or the **OK** soft key.
- Press **4** key.



STEP 8: Select **1 User ID**.

Select an item by either of the following operations.

- Highlight an item by using  or the **UP/DOWN** soft key, and then press  or the **OK** soft key.
- Press **1** key.

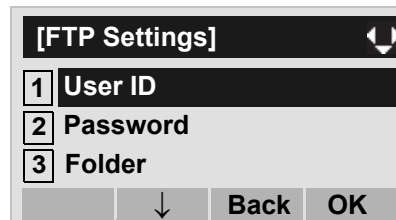

STEP 9: Enter a User ID by using digit keys, then press  or the **OK** soft key.

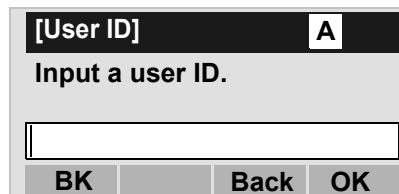







**Note:** For details on character entry method, see [HOW TO INPUT CHARACTERS](#) in Chapter 4 Basic Operation.

STEP 10: The display goes back to the **FTP Settings** screen. Select **2 Password**.

Select an item by either of the following operations.

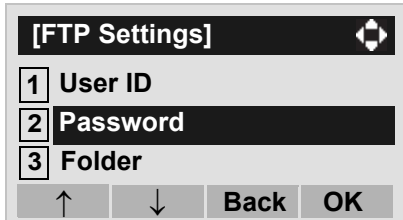
- Highlight an item by using  or the **UP/DOWN** soft key, and then press  or the **OK** soft key.
- Press **2** key.



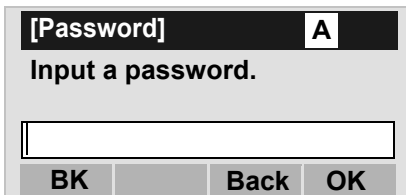

STEP 11: Enter a password by using digit keys, then press  or the **OK** soft key.





**Note:** For details on character entry method, see [HOW TO INPUT CHARACTERS](#) in chapter 4 Basic Operation.

STEP 12: The display goes back to the **FTP Settings** screen. Select **3 Folder**.

Select the item by either of the following operations.

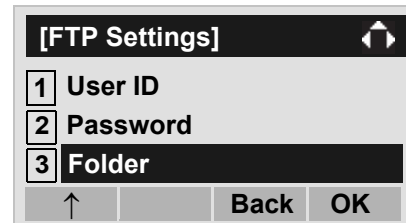
- Highlight an item by using  or the **UP/DOWN** soft key, and then press  or the **OK** soft key.
- Press **3** key.



STEP 13: Enter the directory where the download file is stored and then press  or the **OK** soft key.

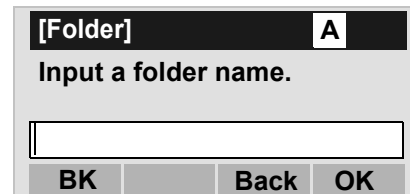

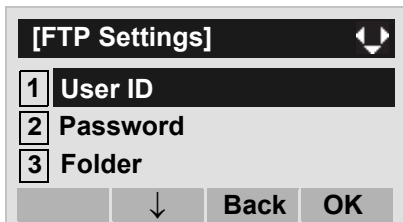

**Note:** For details on character entry method, see [HOW TO INPUT CHARACTERS](#) in chapter 4 Basic Operation.

STEP 14: The display goes back to the **FTP Settings** screen. Press  or the **Back** soft key to display the **Download Menu** screen.



STEP 15: Select **2 Download Address**.

Select an item by either of the following operations.

- Highlight an item by using  or the **UP/DOWN** soft key, and then press ,  or the **OK** soft key.
- Press **2** key.

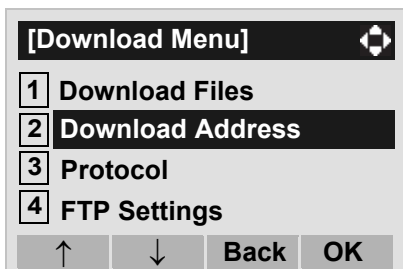

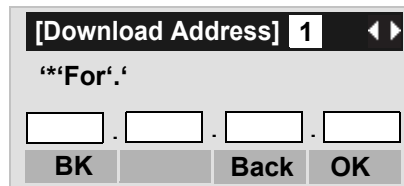

STEP 16: Enter the IP address of the FTP/TFTP server which stores the download file. For example, to set the IP address of 10.41.208.205, enter 10\*41\*208\*205 [separate with an asterisk (\*)].



After entering the IP address, press  or the **OK** soft key.

STEP 17: The display goes back to the **Download Menu** screen. Select **1 Download Files**.

Select an item by either of the following operations.

- Highlight an item by using  or the **UP/DOWN** soft key, and then press ,  or the **OK** soft key.
- Press **1** key.

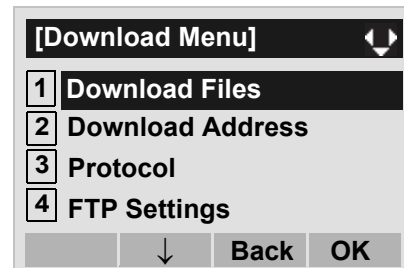

STEP 18: Select a file to be downloaded.

When downloading a file for Music on Hold : Select **1 Hold Music** and go to **STEP 20**.

When downloading a file for ringer tone : Select **2 Ring Tone** and go to **STEP 19**.

When downloading a file for directory : Select **3 Directory** and go to **STEP 20**.



STEP 19: When **2 Ring Tone** is selected at STEP 18, the following **Ring Tone** screen is displayed. Select either **1 Download1**, **2 Download2** or **3 Download3**.

Select an item by either of the following operations.

- Highlight an item by using or the **UP/DOWN** soft key, and then press or the **OK** soft key.
- Press **1** - **3** key.

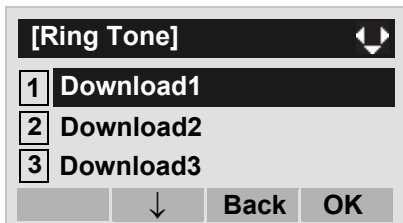

STEP 20: The default file name will be displayed.

- When downloading a file for Music on Hold, the default file name is "MOH.wav".

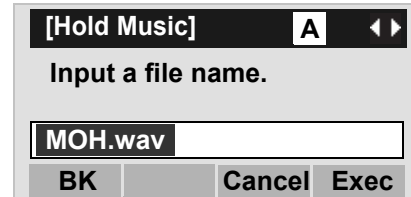

File Format	Maximum Size
PCM $\mu$ -law 8kHz/s wav	under 32 seconds

- When downloading a file for ringer tone, the default file name is "Melody1/2/3.wav".

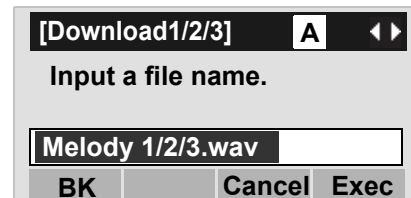

File Format	Maximum Size
PCM $\mu$ -law 8kHz/s wav	under 32 seconds

- When downloading a file for Directory, the default file name is “Directory.csv”.

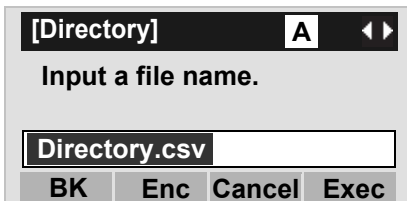

<b>File Name</b>	Directory.csv (Fixed)
<b>Code</b>	Unicode (UTF-8)

Press the **Enc** soft key to download the encrypted file. The encrypted file name is displayed as “Directory.csv.ef”.

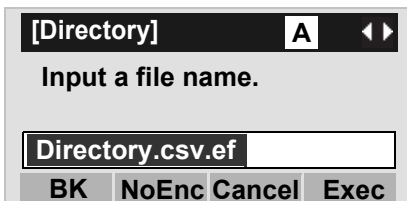

**Note:** If you change the encrypted file into the unencrypted file, press the **NoEnc** soft key.

When changing the file name, go to **STEP 21**.

When not changing the file name, go to **STEP 22**.

**STEP 21:** Press the **BK** soft key once to delete the default file name and then enter a new file name by using the digit keys.

**Note:** For details on character entry method, see [HOW TO INPUT CHARACTERS](#) in chapter 4 Basic Operation.

**Note:** A maximum of 20 characters (“0-9”, “A-Z”, “a-z”, “\*”, “#”, “.”, “-” or “\_”) can be entered as a file name.

**Note:** To delete an entered character, press the **BK** soft key.

**STEP 22:** Press  or the **Exec** soft key to start the downloading process. While downloading a file, the LCD displays “Downloading...” first and then “Saving...”.

**Note:** Be sure not to turn OFF the DT830 Series while “Saving...” is displayed on the LCD.

STEP 23: After the downloading process is complete, the display changes as follows:

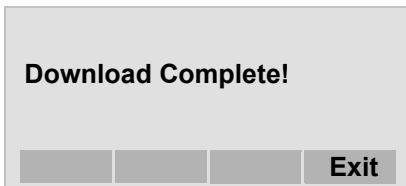

The display goes back to the **Download Files** screen with the **Exit** soft key.

**Note:** When the downloading process ends in failure, "Downloading Failed!" is displayed on the LCD. Check to see the following and then retry.

Check Points	Actions
Download file is not placed in the specified directory.	Place the download file in the specified directory.
A different file name is specified between DT830 Series and FTP/TFTP server.	Set the same file name from both DT830 Series and FTP/TFTP server.
Incorrect IP address of FTP/TFTP server has been entered from the telephone.	Set the proper IP address of FTP/TFTP server.
The power to FTP/TFTP server or network equipment is OFF.	Turn on the power.
LAN cable is disconnected.	Reconnect the cable securely.

## • TO BACKUP PERSONAL SETTINGS

The DT830 Series user can backup personal settings of the terminal to the FTP/TFTP server. To back up the setting data, the terminal needs to be connected to the FTP/TFTP server.

**Note:** For details on the FTP/TFTP service, contact the System administrator.

Before starting the backup, the IP Address of the FTP/TFTP server must be entered from the terminal.

STEP 1: Set up the FTP/TFTP server.

<FTP server>

Confirm the designated directory (for Windows IIS, the default is "C:\inetPub\ftproot") for the backed up file.



<TFTP server>

Specify a desired destination directory for the backed up file.

STEP 2: Display the **Menu** screen, and select **Setting**.

STEP 3: Select **3 Data Backup/Restore**.

Select an item by either of the following operations.

- Highlight an item by using  or the **UP/DOWN** soft key, and then press  or the **OK** soft key.
- Press **3** key.

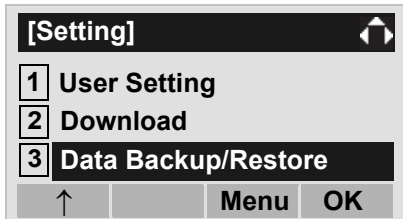

STEP 4: Select **4 Protocol**.

Select an item by either of the following operations.

- Highlight an item by using or the **UP/DOWN** soft key, and then press , or the **OK** soft key.
- Press **4** key.

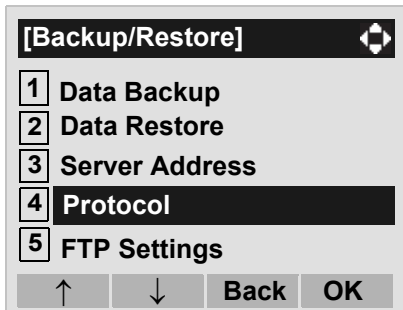

STEP 5: Select a protocol used by the destination server.

Select an item by either of the following operations.

- Highlight an item by using or the **UP/DOWN** soft key, and then press or the **OK** soft key.
- Press **1** or **2** key, and then press or the **OK** soft key.

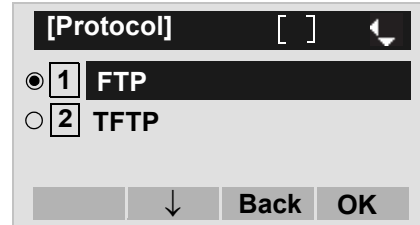

STEP 6: The display goes back to the **Backup/Restore** screen.

When **1 FTP** is selected here, go to STEP 7.

When **2 TFTP** is selected here, go to STEP 15.

STEP 7: Select **5 FTP Settings**.

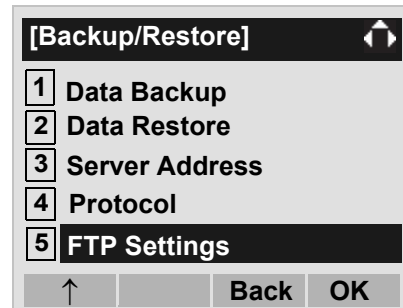

Select an item by either of the following operations.

- Highlight an item by using or the **UP/DOWN** soft key, and then press , or the **OK** soft key.
- Press **5** key.



**STEP 8: Select 1 User ID.**

Select an item by either of the following operations.

- Highlight an item by using  or the **UP/DOWN** soft key, and then press  or the **OK** soft key.
- Press 1 key.

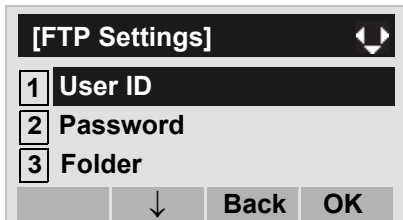

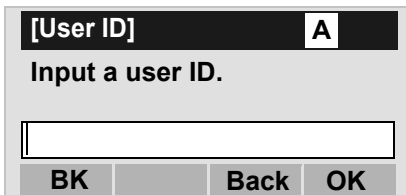

**STEP 9: Enter a User ID by using digit keys, then press  or the **OK** soft key.**





**Note:** For details on character entry method, see [HOW TO INPUT CHARACTERS](#) in chapter 4 Basic Operation.

**STEP 10: The display goes back to the **FTP Settings** screen. Select 2 **Password**.**

Select an item by either of the following operations.

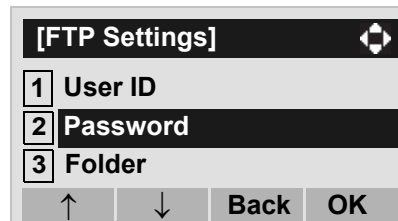
- Highlight an item by using  or the **UP/DOWN** soft key, and then press  or the **OK** soft key.
- Press 2 key.



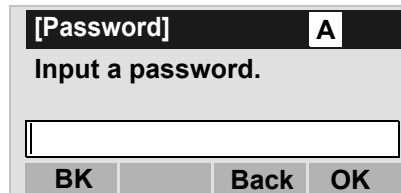

**STEP 11: Enter a password by using digit keys, then press  or the **OK** soft key.**



**Note:** For details on character entry method, see [HOW TO INPUT CHARACTERS](#) in chapter 4 Basic Operation.

**STEP 12: The display goes back to the **FTP Settings** screen. Select 3 **Folder**.**

Select an item by either of the following operations.

- Highlight an item by using  or the **UP/DOWN** soft key, and then press  or the **OK** soft key.
- Press 3 key.

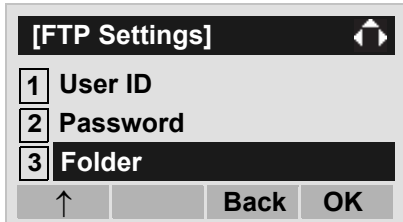

STEP 13: Enter the destination directory of the FTP/TFTP server and then press or the **OK** soft key.

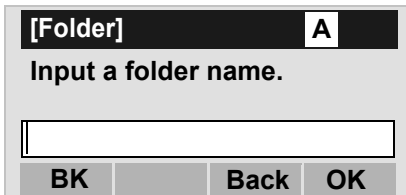

**Note:** For details on character entry method, see [HOW TO INPUT CHARACTERS](#) in chapter 4 Basic Operation.

STEP 14: The display goes back to the **FTP Settings** screen. Press or the **Back** soft key to display the **Backup/Restore** screen.

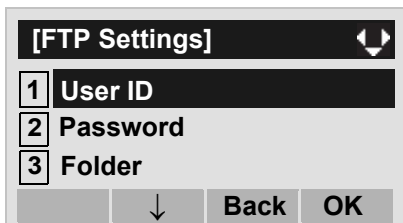

STEP 15: Select **3 Server Address**.

- Select an item by either of the following operations.
- Highlight an item by using or the **UP/DOWN** soft key, and then press , or the **OK** soft key.
  - Press **3** key.

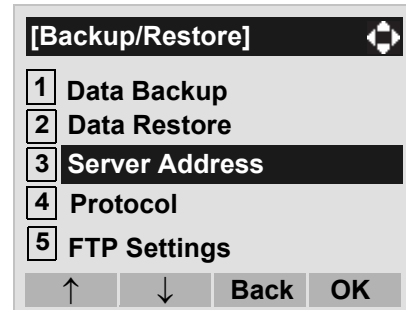

STEP 16: Enter the IP address of the destination FTP/TFTP server. For example, to set the IP address of 10.41.208.205, enter 10\*41\*208\*205 [separate with an asterisk (\*)].

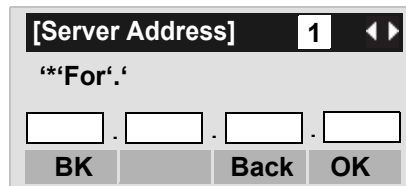



After entering the IP address, press or the **OK** soft key.



STEP 17: The display goes back to the **Backup/Restore** screen. Select **1 Data Backup**.

Select an item by either of the following operations.

- Highlight an item by using  or the **UP/DOWN** soft key, and then press  or the **OK** soft key.
- Press **1** key.

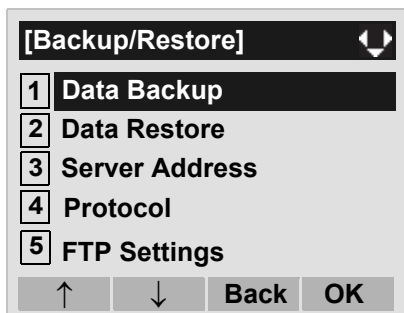

STEP 18: The default file name is displayed as follows:

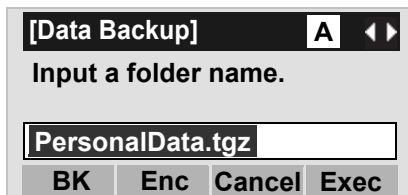

**Note:** Do not change the extension of the backup file. The setting data of the telephone can only be backed up as a.tgz file.

**Note:** When changing the default file name, press the **BK** soft key once to delete the default file name and then enter a new file name by using the digits keys.

**Note:** For details on character entry method, see [HOW TO INPUT CHARACTERS](#) in chapter 4 Basic Operation.

**Note:** A maximum of 20 characters ("0-9", "A-Z", "a-z", "\*", "#", ".", "-", "\_") can be entered as a file name.

**Note:** To delete an entered character, press the **BK** soft key.

Press the **Enc** soft key to download the encrypted backup file.

The encrypted backup file name is displayed as "PersonalData.tgz.ef".

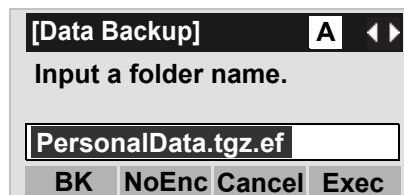

**Note:** If you make the unencrypted file, press the **NoEnc** soft key.

STEP 19: Press  or the **Exec** soft key to start the data backup. While making a backup copy, the LCD displays "Uploading..." first and then "Saving...".

**Note:** Be sure not to turn OFF the DT830 Series while "Saving..." is displayed on the LCD.

STEP 20: After the data backup is complete, the display changes as follows:

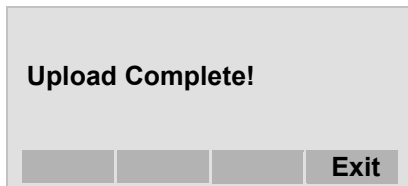

The display goes back to the **Backup/Restore** screen with the **Exit** soft key.

**Note:** When the data backup ends in failure, "Upload Failed!" is displayed on the LCD. Check to see the following and then make a retry.

Check Points	Actions
A different file name is specified between DT830 Series and FTP/TFTP server.	Set the same file name from both DT830 Series and FTP/TFTP server.
Incorrect IP address of FTP/TFTP server has been entered from the telephone.	Set the proper IP address of FTP/TFTP server.
The power to FTP/TFTP server or network equipment is OFF.	Turn on the power.
LAN cable is disconnected.	Reconnect the cable securely.

## • TO RESTORE PERSONAL SETTINGS

The DT830 Series user can restore the personal settings of the terminal. To download the backup file to the telephone, the terminal needs to be connected to FTP/TFTP server.

**Note:** For details on the FTP/TFTP service, contact the System administrator.

Before starting the download, the IP Address of the FTP/TFTP server must be entered from the terminal.

STEP 1: Set up the FTP/TFTP server.

<FTP server>

Put the backup file you want to restore into the designated directory (for Windows IIS, the default is "C:\inetPub\ftproot") of the FTP server.



<TFTP server>

Put the backup file you want to restore into a desired directory of the TFTP server and then specify it as the directory for downloading.

STEP 2: Display the **Menu** screen, and select **Setting**.

STEP 3: Select **3 Data Backup/Restore**.

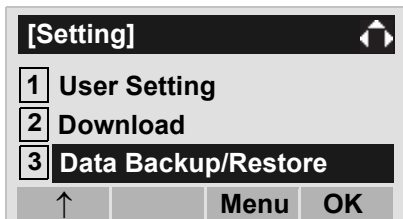

Select an item by either of the following operations.

- Highlight an item by using  or the **UP/DOWN** soft key, and then press  or the **OK** soft key.
- Press **3** key.



STEP 4: Select **4 Protocol**.

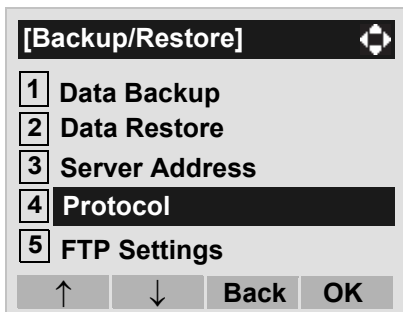

Select an item by either of the following operations.

- Highlight an item by using  or the **UP/DOWN** soft key, and then press  or the **OK** soft key.
- Press **4** key.



STEP 5: Select a protocol used by the server which stores the backup file.

Select an item by either of the following operations.

- Highlight an item by using  or the **UP/DOWN** soft key, and then press  or the **OK** soft key.
- Press **1** or **2** key, and then press  or the **OK** soft key.

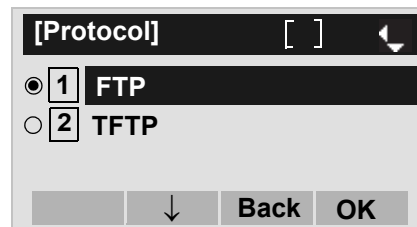



STEP 6: The display goes back to the **Backup/Restore** screen.

When **1 FTP** is selected here, go to STEP 7.

When **2 TFTP** is selected here, go to STEP 15.

**STEP 7: Select [5] FTP Settings.**

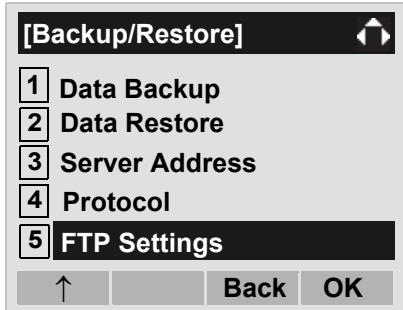

Select an item by either of the following operations.

- Highlight an item by using  or the **UP/DOWN** soft key, and then press ,  or the **OK** soft key.
- Press **(5)** key.



**STEP 8: Select [1] User ID.**

Select an item by either of the following operations.

- Highlight an item by using  or the **UP/DOWN** soft key, and then press ,  or the **OK** soft key.
- Press **(1)** key.

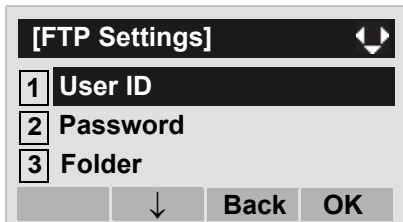

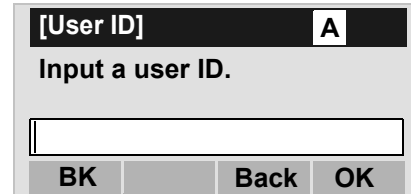

**STEP 9: Enter the User ID by using digit keys, then press  or the **OK** soft key.**





**Note:** For details on character entry method, see [HOW TO INPUT CHARACTERS](#) in chapter 4 Basic Operation.

**STEP 10:** The display goes back to the **FTP Settings** screen. Select **[2] Password**.

Select an item by either of the following operations.

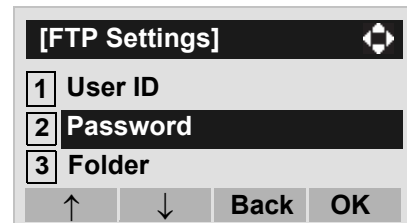
- Highlight an item by using  or the **UP/DOWN** soft key, and then press ,  or the **OK** soft key.
- Press **(2)** key.



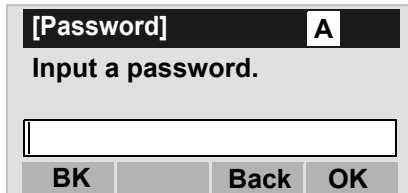

STEP 11: Enter the password by using digit keys, then press  or the **OK** soft key.





**Note:** For details on character entry method, see [HOW TO INPUT CHARACTERS](#) in chapter 4 Basic Operation.

STEP 12: The display goes back to the **FTP Settings** screen. Select **3 Folder**.

Select an item by either of the following operations.

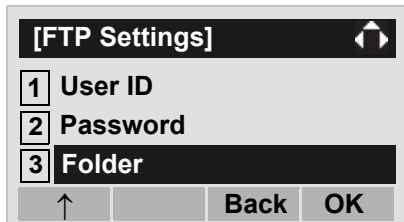
- Highlight an item by using  or the **UP/DOWN** soft key, and then press  or the **OK** soft key.
- Press **3** key.



STEP 13: Enter the directory where the backup file is stored and then press  or the **OK** soft key.

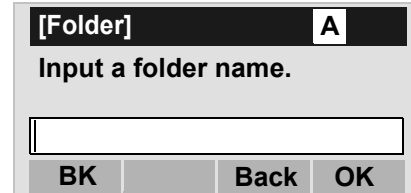

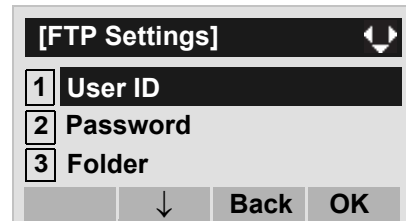

**Note:** For details on character entry method, see [HOW TO INPUT CHARACTERS](#) in chapter 4 Basic Operation.

STEP 14: The display goes back to the **FTP Settings** screen. Press  or the **Back** soft key to display the **Backup/Restore** screen.



STEP 15: Select **3** **Server Address**.

Select an item by either of the following operations.

- Highlight an item by using  or the **UP/DOWN** soft key, and then press ,  or the **OK** soft key.
- Press **3** key.

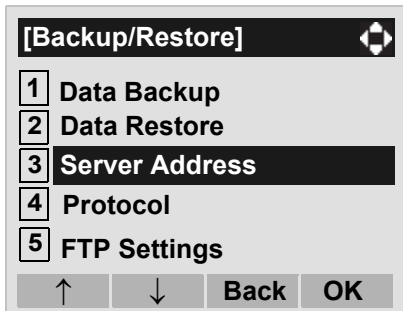

STEP 16: Enter the IP address of the FTP/TFTP server which stores the backup file. For example, to set the IP address of 10.41.208.205, enter 10\*41\*208\*205 [separate with an asterisk (\*)].

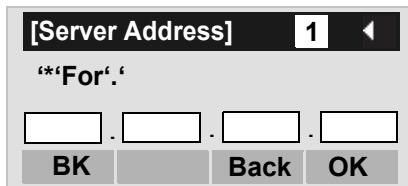



After entering the IP address, press  or the **OK** soft key.

STEP 17: The display goes back to the **Backup/Re-**

**store** screen. Select **2** **Data Restore**.

Select an item by either of the following operations.

- Highlight an item by using  or the **UP/DOWN** soft key, and then press ,  or the **OK** soft key.
- Press **2** key.

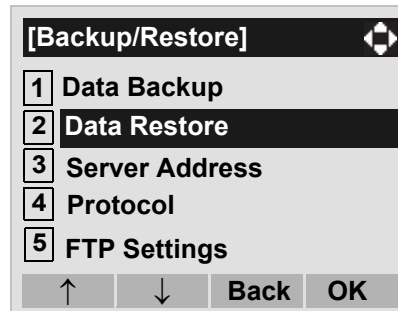

STEP 18: The default file name will be displayed as follows:



**Note:** Do not change the extension (.tgz) of the backup file. If the extension is changed, the file cannot be restored properly.

**Note:** When changing the default file name, press the **BK** soft key once to delete the default file name and then enter a new file name by using the digits keys.

**Note:** For details on character entry method, see [HOW TO INPUT CHARACTERS](#) in chapter 4 Basic Operation.

**Note:** A maximum of 20 characters (“0-9”, “A-Z”, “a-z”, “\*”, “#”, “.”, “-” or “\_”) can be entered as a file name.

**Note:** To delete an entered character, press the **BK** soft key.

Press the **Enc** soft key to download the encrypted restore file.

The encrypted restore file name is displayed as “PersonalData.tgz.ef”.

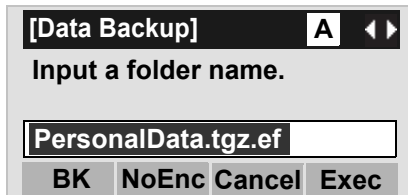

**Note:** If you change the encrypted file into the unencrypted file, press the **NoEnc** soft key.

STEP 19: Press  or the **Exec** soft key to start restoring the backup data to the telephone. While downloading the backup data, the LCD displays “Downloading...” first and then “Saving...”.

**Note:** Be sure not to turn OFF the DT830 Series while “Saving...” is displayed on the LCD.

STEP 20: After the downloading process is complete, the display changes as follows:

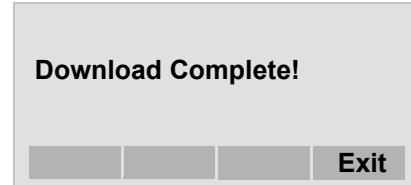

The display goes back to the **Backup/Restore** screen by the **Exit** soft key.

**Note:** When the downloading process ends in failure, “Download Failed!” is displayed on the LCD. Check to see the following and then make a retry.

Check Points	Actions
Download file is not placed in the specified directory.	Place the download file in the specified directory.
A different file name is specified between DT830 Series and FTP/TFTP server.	Set the same file name from both DT830 Series and FTP/TFTP server.
Incorrect IP address of FTP/TFTP server has been entered from the telephone.	Set the proper IP address of FTP/TFTP server.
The power to FTP/TFTP server or network equipment is OFF.	Turn on the power.
LAN cable is disconnected.	Reconnect the cable securely.



## SETUP WITH MENU KEY FOR DT430 SERIES

### • TO CHANGE RINGER TONE VOLUME

The procedure below shows how to change the volume of ringer tone.

STEP 1: While indicating the current time on LCD, press **Menu** key to open the **Menu** screen. Then, select **3 Settings**.

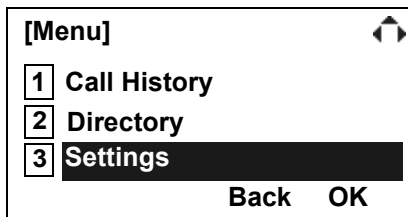

Select an item by either of the following operations.

- Highlight an item by using , and then press ,  or the **OK** soft key.
- Press **3** key.





STEP 2: Select **1 Ring Volume**.

Select an item by either of the following operations.

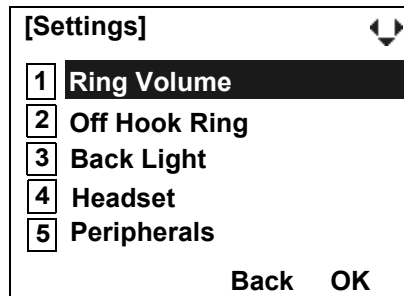
- Highlight an item by using , and then press ,  or **OK** soft key.
- Press **1** key.



STEP 3: Ring Volume can be set in 13 levels (0 - 12). Adjust the ringer tone volume by using  key and then press  or the **OK** soft key.

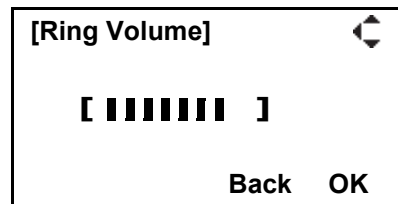
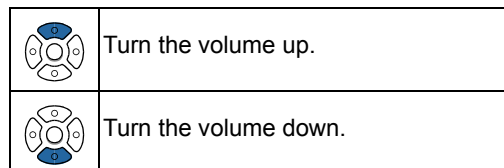





## • TO ENABLE/DISABLE OFF-HOOK RINGING

The procedure below shows how to enable/disable the off-hook ringing.

STEP 1: While indicating the current time on LCD, press **Menu** key to open the **Menu** screen. Then, select **3 Settings**.



Select an item by either of the following operations.

- Highlight an item by using , and then press ,  or the **OK** soft key.
- Press **3** key.



STEP 2: Select **2 Off Hook Ring**.

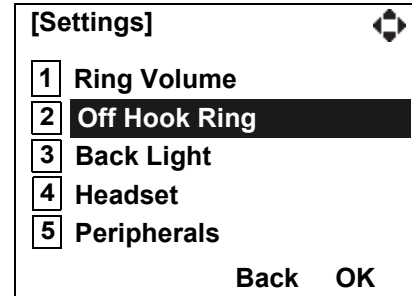

Select an item by either of the following operations.

- Highlight an item by using , and then press ,  or the **OK** soft key.
- Press **2** key.



STEP 3: To disable/enable the off-hook ringing, select **1 Disable** or **2 Enable**.

Select an item by either of the following operations.

- Highlight an item by using , and then press  or the **OK** soft key.
- Press **1** or **2** key, and then press  or the **OK** soft key.

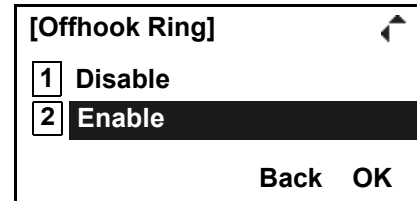

**Note:** Default setting is **2 Enable**.

**Note:** The enabled item is highlighted.



## • TO ENABLE/DISABLE BACKLIGHT

The following explains how to enable/disable the backlights of LCD and digit keys.

The backlights illuminate (for approximately 10 seconds) when you press any key or lift the handset.

STEP 1: While indicating the current time on LCD, press **Menu** key to open the **Menu** screen. Then, select **3 Settings**.

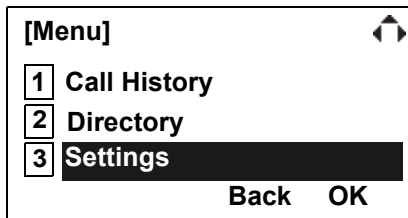

Select an item by either of the following operations.

- Highlight an item by using , and then press ,  or the **OK** soft key.
- Press **3** key.



STEP 2: Select **3 Back Light**.

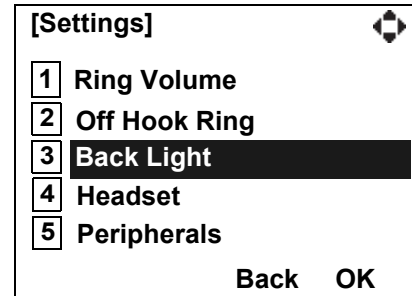

Select an item by either of the following operations.

- Highlight an item by using , and then press ,  or the **OK** soft key.
- Press **3** key.



STEP 3: Make a selection from the following list.

Select an item by either of the following operations.

- Highlight an item by using , and then press  or the **OK** soft key.
- Press **1** or **2** key, and then press  or the **OK** soft key.

No.	Menu Item	Meaning
1	Disable	Backlights of LCD and digit keys are disabled.
2	Enable	Backlights of LCD and digit keys are enabled.

**Note:** Default setting is **2 Enable**.

**Note:** The enabled item is highlighted.

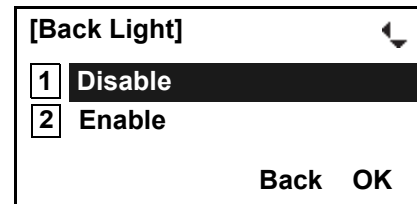



STEP 4: After Making a selection, press  or the **OK** soft key.

## • TO SET RINGING OF HEADSET

The procedure below shows how to enable/disable the ringing of headset.

STEP 1: While indicating the current time on LCD, press  key to open the **Menu** screen. Then, select **3 Settings**.

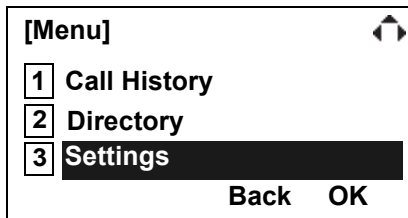

Select an item by either of the following operations.

- Highlight an item by using , and then press ,  or the **OK** soft key.
- Press **3** key.



STEP 2: Select **4 Headset**.

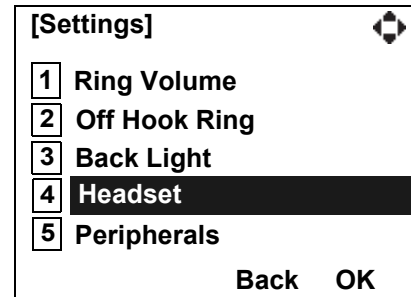

Select an item by either of the following operations.

- Highlight an item by using , and then press ,  or the **OK** soft key.
- Press **4** key.



STEP 3: To disable/enable the ringing of headset, select **1 Disable** or **2 Enable**.

Select an item by either of the following operations.

- Highlight an item by using , and then press  or the **OK** soft key.
- Press **1** or **2** key, and then press  or the **OK** soft key.

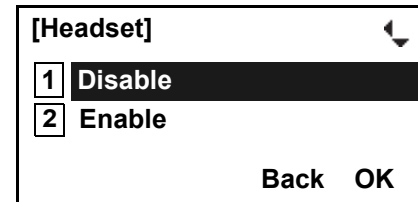

**Note:** Default setting is **1 Disable**.

**Note:** The enabled item is highlighted.

# 4. BASIC OPERATION

---

This chapter describes the following basic operation of DT Series.

- TO LOGIN
- TO LOGOUT
- DISPLAY ENLARGED CHARACTERS
- TO MAKE AN EXTERNAL CALL
- TO MAKE AN INTERNAL CALL
- TO ANSWER AN EXTERNAL CALL
- TO ANSWER AN INTERNAL CALL
- MULTILINE OPERATION
- TO HOLD A CALL
- TO PLACE A CALL ON EXCLUSIVE HOLD
- TO TRANSFER A CALL
- HOW TO INPUT CHARACTERS
- HOW TO INPUT CHARACTERS
- SECURITY MODE
- EMERGENCY CALL
- XML APPLICATION
- SCREEN POP-UP

## TO LOGIN **DT830**

STEP 1: When the login mode is activated, the telephone prompts for Login ID and Password.

Login ID :	-		
Password :			
Cancel	Back	Set	OK

STEP 2: Enter the login code and press the **Set** soft key.  
(Station number is used as the Login code.)

Login ID :	31313		
Password :			
Cancel	Back	Set	OK

STEP 3: Enter the password and press the **OK** soft key.

Login ID :	31313		
Password :	*****		
Cancel	Back	Set	OK

STEP 4: If the login code is accepted, display changes to a normal idle state.

Ken Kobus	[31313 ]	
7:25 AM MON 11 MAY 2015		
Mic	NoDist	>>>

**Note:** The LCD can display the My Line information (name and station number) when the station is in an idle state. For details, please contact the system administrator.

## TO LOGOUT **DT830**

STEP 1: Press the preassigned **Logout** Feature key on the terminal.

**Note:** The following soft key location is an example.

**Note:** The **Logout** key is assigned by the system administrator.

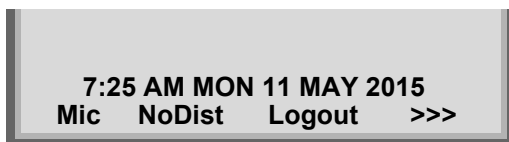

STEP 2: “**LOGOUT?**” is displayed on the LCD of the terminal.

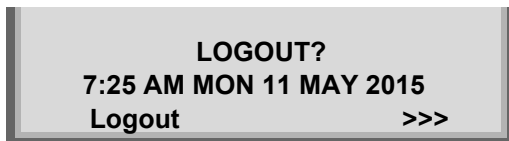

STEP 3: Press the **Logout** Feature key again, or the Logout soft key on the terminal. The terminal displays the Login screen.

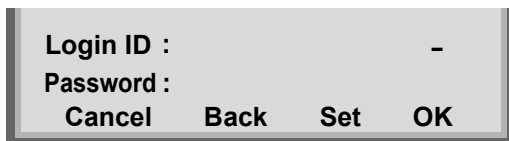

## DISPLAY ENLARGED CHARACTERS **DT830**

This feature enables to display characters height as a double height size for the terminal information on the LCD. The indication of enlarged characters is available for 2nd line or 3rd line on the LCD. The line displayed as enlarged characters can be switched by using the Line/Feature key for “Display Enlarged Characters”.

**Note:** The feature key of “Display Enlarged Characters” is assigned at installation. For details, contact the system administrator.

## To Switch the Line Indicating Double Height Characters

By pressing the soft key or the Line/Feature key, you can switch the characters displayed to double height in the order of "Enlarged Characters (2nd line)" → "Enlarged Characters (3rd line)" → "No Enlarged Characters".

The following shows an example when using this feature.

- No Enlarged Characters

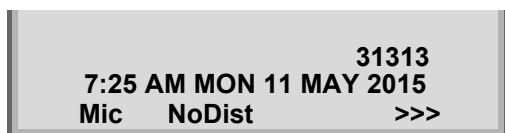

31313  
7:25 AM MON 11 MAY 2015  
Mic NoDist >>>

- Enlarged Characters (2nd line)

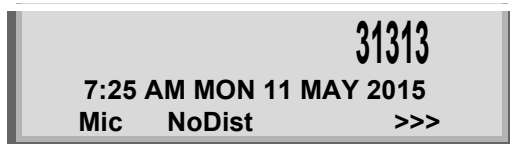

31313  
7:25 AM MON 11 MAY 2015  
Mic NoDist >>>

- Enlarged Characters (3rd line)



31313  
7:25 AM MON 11 MAY 2015  
Mic NoDist >>>

## TO MAKE AN EXTERNAL CALL

### DT830 DT430/410

When a dialed telephone number is registered in Personal Directory, the corresponding name information will be displayed on LCD of DT830 Series while you are hearing a ringback tone or are engaged in a conversation. According to the initial settings, the display may differ from the following examples. For more information, contact the system administrator.

**Note:** Personal Directory Name Display function is available only for DT830 Series.

**Note:** Here describes the Normal Dial Mode. Regarding the other mode, see TO ORIGINATE A CALL USING SELECTIVE DIALING (DYNAMIC DIAL PAD, PRESET DIAL) in Chapter 5.

STEP 1: Lift the handset or press  key, receive a dial tone.

My Line Information (Name and Station Number)

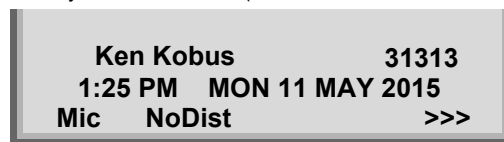

Ken Kobus 31313  
1:25 PM MON 11 MAY 2015  
Mic NoDist >>>

STEP 2: Dial the Central Office access code, e.g. **9**.

Dialed Code

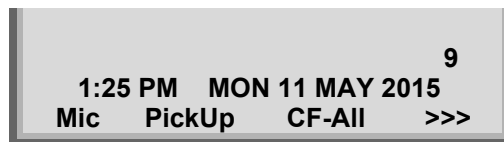

9  
1:25 PM MON 11 MAY 2015  
Mic PickUp CF-All >>>

STEP 3: Dial desired telephone number.

(while hearing a ringback tone)

Dial Code + Number			
		9XXXXXXXXX	
1:25 PM	MON 11 MAY 2015		
Mic	PickUp	CF-All	>>>

STEP 4: Use the handset or Mic to start a conversation. Display indicates:

(while in a conversation)

- When the dialed number is registered in Personal Directory

Name Information registered in Personal Directory	Elapsed Time	Dial Code + Number
TOM JONES	00:05	9XXXXXX*
Mic	NoDist	>>>

**Note:** In the above case, a maximum of eight digits of the number (including “\*”) can be displayed. If the dialed number exceeds eight digits, “the first seven digits of the number” + “\*” or “the last seven digits of the number” + “\*” are displayed. For more information, please contact the system administrator.

- When the dialed number is not registered in Personal Directory

Elapsed Time		Dial Code + Number
	00:05	9XXXXXXXXX
Mic	NoDist	>>>

**Note:** My Line is an actual line that is directly associated with station number of the telephone. You can make/answer a call via this line. Usually, My Line is seized automatically only by lifting the handset or pressing the **Speaker** key.



## TO MAKE AN INTERNAL CALL

### DT830 DT430/410

When a dialed station number is registered in Personal Directory, the corresponding name information is displayed on the LCD of DT830 Series while you are hearing a ringback tone or are engaged in a conversation. According to the initial settings, the display may differ from the following examples. For more information, contact the system administrator.

**Note:** Personal Directory Name Display function is available only for DT830 Series.

**Note:** Here describes the Normal Dial Mode. About the other mode, see [TO ORIGINATE A CALL USING SELECTIVE DIALING \(DYNAMIC DIAL PAD, PRE-SET DIAL\)](#) in chapter 5.

STEP 1: Lift the handset or press  key, receive a dial tone.

Blink → My Line Information  
(Name and Station Number)

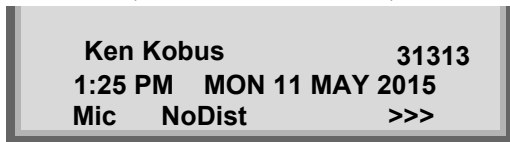

STEP 2: Dial the desired station number. Display indicates digits dialed.

(while hearing a ringback tone)

- When the dialed station number is registered in Personal Directory

Name Information registered  
in Personal Directory      Dialed Station Number

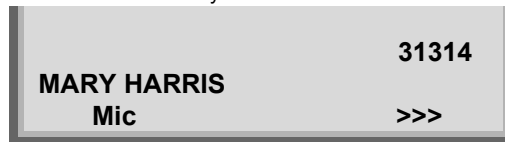

- When the dialed station number is not registered in Personal Directory

Dialed Station Number

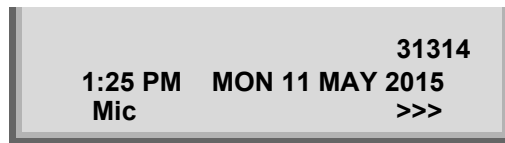

STEP 3: Use the handset or Mic to start a conversation.

(while in a conversation)

- When the dialed station number is registered in Personal Directory

Name Information  
registered in  
Personal Directory      Dialed Station Number

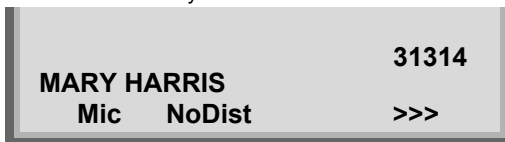

- When the dialed station number is not registered in Personal Directory

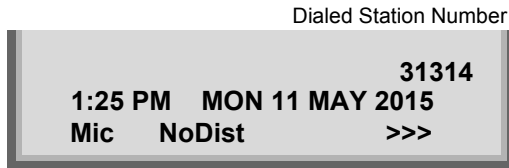

**Note:** My Line is an actual line that is directly associated with station number of the telephone. You can make/answer a call via this line. Usually, My Line is seized automatically only by lifting the handset or pressing the **Speaker** key.

## TO ANSWER AN EXTERNAL CALL

### DT830 DT430/410

When a calling party telephone number is registered in Personal Directory, the corresponding name information is displayed on the LCD while you are hearing a ringing tone or are engaged in a conversation. According to the initial settings, the display may differ from the above example. For more information, contact the system administrator.

**Note:** Personal Directory Name Display function is available only for DT830 Series.

STEP 1: You hear the ringing tone. Call indicator flashes red while hearing ring tone.

- When the calling party telephone number is registered in Personal Directory

Name Information registered  
in Personal Directory

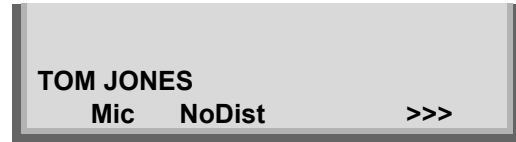

- When calling party telephone number is not registered in Personal Directory

Calling Party  
Telephone Number

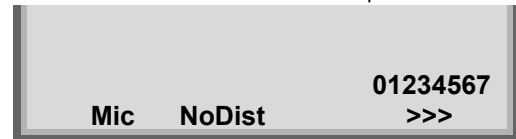

- When caller ID is not received

	Trunk Type	Trunk Number
1:25 PM	DDD	3
Mic	NoDist	>>>
MON 11 MAY 2015		

- When the caller ID is not received

	Elapsed Time	Trunk Type	Trunk Number
1:25 PM	00:05	DDD	3
Mic	NoDist	>>>	
MON 11 MAY 2015			

STEP 2: Press **Answer** key or touch the appropriate Line key.

STEP 3: Lift the handset to answer the call.

(while in a conversation)

- When the calling party telephone number is registered in Personal Directory

Name Information registered in Personal Directory      Elapsed Time

TOM JONES	00:05
Mic	NoDist >>>

- When the calling party telephone number is not registered in Personal Directory

Elapsed Time      Calling Party Telephone Number

00:05	01234567
Mic	NoDist >>>

**Note:** When an incoming call is terminated to My Line of the telephone, you can usually answer the call only by lifting the handset or pressing the **Speaker** key.

## TO ANSWER AN INTERNAL CALL

The following procedure explains how to answer an internal call routed to My Line of the telephone.

When a calling station number is registered in Personal Directory, the corresponding name information is displayed on the LCD of DT830 Series while you are hearing a ringing tone or are engaged in a conversation. According to the initial settings, the display may differ from the above example. For more information, contact the system administrator.

**Note:** Personal Directory Name Display function is available only for DT830 Series.

STEP 1: You hear the ringing tone. Call indicator flashes red while hearing ring tone.

- When the calling station number is registered in Personal Directory

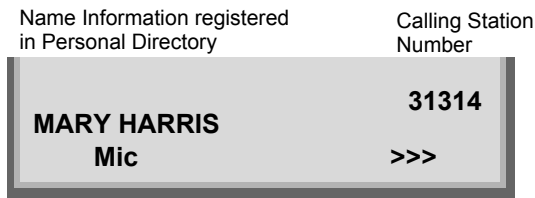

- When the calling station number is not registered in Personal Directory

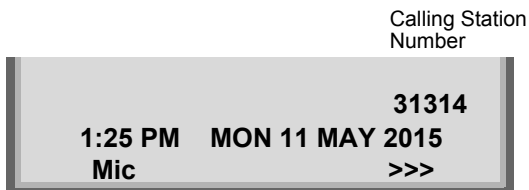

STEP 2: Press **Answer** key or touch the appropriate Line key.

STEP 3: Lift the handset to answer the call.

(while in a conversation)

- When calling station number is registered in Personal Directory

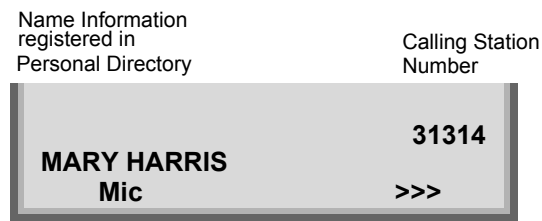

- When calling station number is not registered in Personal Directory

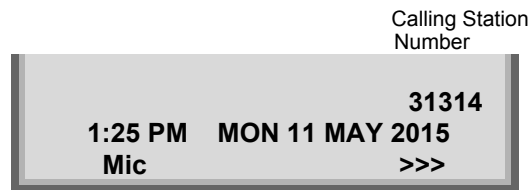

**Note:** When an incoming call is terminated to My Line of the telephone, you can usually answer the call only by lifting the handset or pressing the **Speaker** key.

## MULTILINE OPERATION

### DT830 DT430/410

You can answer an incoming call to the other station to press the **MULTILINE** key (which is preassigned the other station number).

#### To Originate a Call

STEP 1: Press the **MULTILINE** key.

STEP 2: Lift the handset or press **Speaker** key. Dial the Central Office access code (i.e.9 (US), 0 (Aust)).

STEP 3: Dial the desired number.

#### To Answer a Call

STEP 1: Press the **MULTILINE** key (ringing and flashing LED alert user to incoming call).

STEP 2: Lift the handset or press **Speaker** key.

STEP 3: Speak with the incoming party.

## TO HOLD A CALL DT830 DT430/410

STEP 1: Press **HOLD** key. The held line key wink flashes.

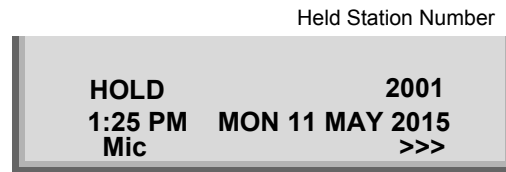

**Note:** If held line appears on other stations, the associated LED flashes red slowly.

#### To Retrieve

STEP 1: Lift the handset or press **Speaker** key.

STEP 2: Press the held line key. Use the handset to converse.

**Note:** Any station with this line key appearance can retrieve the call.

#### If unanswered

STEP 1: After preprogrammed time, Automatic Recall is initiated.

STEP 2: Visual and audible signal (rapid flash and ring burst) is sent to the station that placed call on hold.

**Note:** **Hold** shows as a flashing green LED on your phone. The same line on other phones shows as a flashing red LED. **Recall** shows as a flashing green LED on your phone and flashing red LED on other phones with the same line.

## TO PLACE A CALL ON EXCLUSIVE HOLD **DT830** **DT430/410**

STEP 1: Press **HOLD** key twice. The line key appearance indicates interrupted wink.

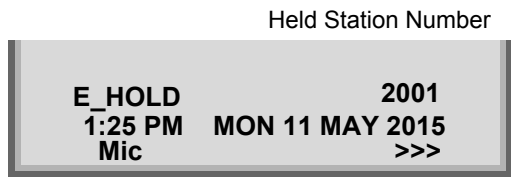

**Note:** If held line key appears on other stations, LED remains steadily lit red.

### To Retrieve

STEP 1: Lift the handset or press **Speaker** key.

STEP 2: Press the held line key. Use the handset to converse.

**Note:** Only the terminal that set Exclusive Hold option can retrieve the call.

### If unanswered

STEP 1: After preprogrammed time, Automatic Recall is initiated.

STEP 2: Visual and audible signal (rapid flash and ring burst) is sent to the station which placed call on Exclusive Hold. **Recall** shows as a flashing green LED on your phone, and solid red on other phones with same line.

**Note:** Exclusive Hold excludes any other phone from picking up your held call. Exclusive Hold shows as a flashing green LED on your phone. The same line on other phones appears as a solid red LED.

## TO TRANSFER A CALL

**DT830** **DT430/410**

STEP 1: After conversing, ask the other party to hold.

STEP 2: Press **Transfer** key. Receive an interrupted dial tone.

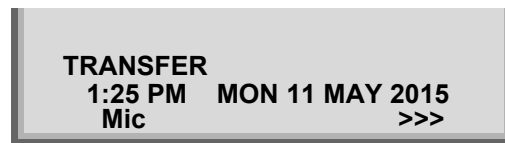

STEP 3: Dial destination station's extension, hang up or wait for answer.

Transferred station  
or trunk number

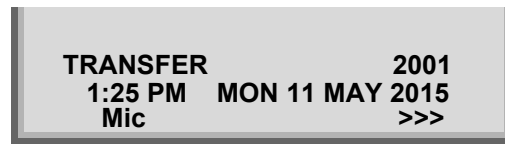

STEP 4: If transferring party hangs up, that station's number appears in the center of recipient's display.

Transferring station



## HOW TO INPUT CHARACTERS DT830

Here explains how to enter characters on the text input screen such as Name or User ID, etc.

### • Character Entry Mode

When entering characters from the telephone set, the following three modes are available: uppercase alphabetic character, lowercase alphabetic character and numeric character. The character entry mode can be changed by pressing  key (alphabetic/numeric) or from the Sub Menu screen (uppercase/lowercase).

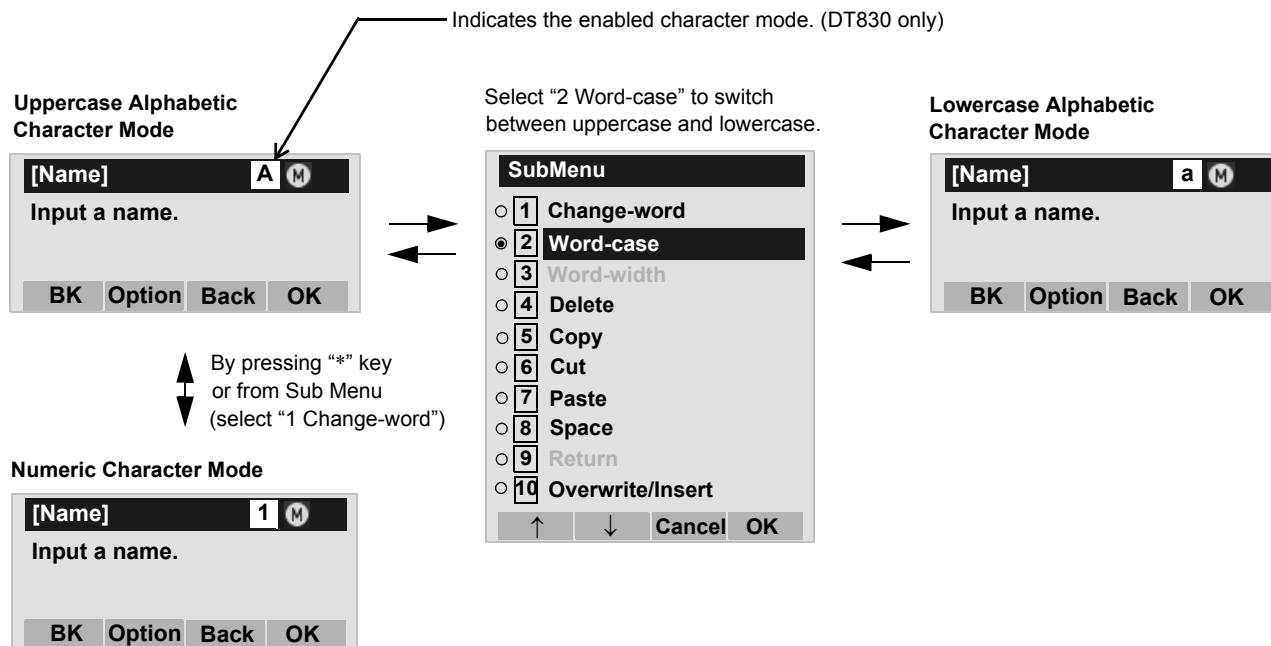

The enabled entry mode is indicated in the top portion of the LCD screen.

To display the Sub Menu screen, press the **Help** key or **Option** soft key while the text input screen is displayed. Also, the following operations are available from the Sub Menu screen.

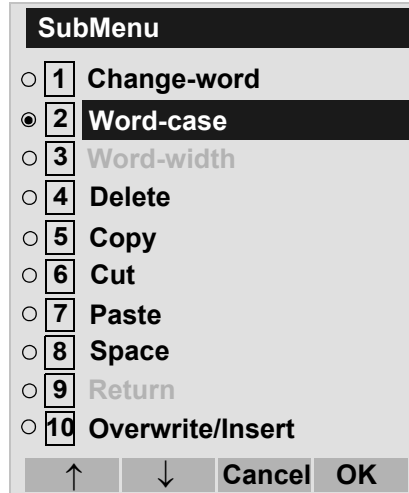

Sub Menu Items	Descriptions
Change-word	Change character entry mode between uppercase alphabetic, lowercase alphabetic and numeric character.
Word-case	Switch between uppercase and lowercase.
Word-width	Not used.
Delete	Delete a single character.
Copy	Copy the specified characters.
Cut	Cut the specified characters.
Paste	Paste the specified characters.
Space	Enter a space.
Return	Start a new line.
Overwrite/Insert	Write over existing characters.



• **Character Code List**

<Character Code For English (1/2)>

DIGIT KEY	CASE SHIFT	1st	2nd	3rd	4th	5th	6th	7th	8th	9th	10th	11th	12th	13th
①	A	.	,	\	1	?	!	@	:	;				
	a													
②	A	A	B	C	2									
	a	a	b	c	2									
③	A	D	E	F	3									
	a	d	e	f	3									
④	A	G	H	I	4									
	a	g	h	i	4									
⑤	A	J	K	L	5									
	a	j	k	l	5									
⑥	A	M	N	O	6									
	a	m	n	o	6									
⑦	A	P	Q	R	S	7								
	a	p	q	r	s	7								
⑧	A	T	U	V	8									
	a	t	u	v	8									
⑨	A	W	X	Y	Z	9								
	a	w	x	y	z	9								
⑩	A	[SP]	0											
	a													

## <Character Code For English (2/2)>

		1st	2nd	3rd	4th	5th	6th	7th	8th	9th	10th
 <b>Note1</b>		*	#	.	/	:	~	!	@	\$	%
		11th	12th	13th	14th	15th	16th	17th	18th	19th	20th
		^	&	(	)	'	?		_	+	-
		21th	22th	23th	24th	25th	26th	27th	28th	29th	30th
		=	[	]	{	}	<	>	,	;	\
 <b>Note1</b>	Used as a case shift key. Shifts the characters between alphabetic and numeric.										

**Note1:** and keys are the same for Russian, Turkish and other Languages.

<Character Code For Russian>

DIGIT KEY	CASE SHIFT	1st	2nd	3rd	4th	5th	6th	7th	8th	9th	10th	11th	12th	13th	14th	15th
①	⌈A	.	,	:	!	?	+	-	%	&	/	(	)	=	¿	¡
	⌋a															
②	⌈A	А	Б	В	Г											
	⌋a	а	б	в	г											
③	⌈A	Д	Е	Ё	Ж	З										
	⌋a	д	е	ё	ж	з										
④	⌈A	И	Й	К	Л											
	⌋a	и	й	к	л											
⑤	⌈A	М	Н	О	П											
	⌋a	м	н	о	п											
⑥	⌈A	Р	С	Т	У											
	⌋a	р	с	т	у											
⑦	⌈A	Ф	Х	Ц	Ч											
	⌋a	ф	х	ц	ч											
⑧	⌈A	Ш	Щ	Ъ	Ы	Ь										
	⌋a	ш	щ	ъ	ы	ь										
⑨	⌈A	Э	Ю	Я												
	⌋a	э	ю	я												
⑩	⌈A	[SP]														
	⌋a															

**Note:** Ⓝ and ✖ keys are the same for English. Refer to the <Character Code For English (2/2)>.

<Character Code For Turkish>

DIGIT KEY	CASE SHIFT	1st	2nd	3rd	4th	5th	6th	7th	8th	9th	10th	11th	12th	13th	14th	15th
①	A	.	,	:	!	?	+	-	%	&	/	(	)	=	ı	i
	a															
②	A	A	B	C	Ç											
	a	a	b	c	ç											
③	A	D	E	F												
	a	d	e	f												
④	A	G	Ğ	H	I	İ										
	a	g	ğ	h	i	ı										
⑤	A	J	K	L												
	a	j	k	l												
⑥	A	M	N	O	Ö											
	a	m	n	o	ö											
⑦	A	P	R	S	Ş											
	a	p	r	s	ş											
⑧	A	T	U	Ü	V											
	a	t	u	ü	v											
⑨	A	Y	Z													
	a	y	z													
⑩	A	[SP]														
	a															

**Note:** ① and ② keys are the same for English. Refer to the <Character Code For English (2/2)>.

## <Character Code For Other Languages>

DIGIT KEY	CASE SHIFT	1st	2nd	3rd	4th	5th	6th	7th	8th	9th	10th	11th	12th	13th	14th	15th
①	A	.	,	:	!	?	+	-	%	&	/	(	)	=	¿	i
	a															
②	A	A	B	C	À	Á	Â	Ã	Ä	Å	Æ	Ç				
	a	a	b	c	à	á	â	ã	ä	å	æ	ç				
③	A	D	E	F	È	É	Ê	Ë								
	a	d	e	f	è	é	ê	ë								
④	A	G	H	I	Ì	Í	Î	Ï								
	a	g	h	i	ì	í	î	ï								
⑤	A	J	K	L												
	a	j	k	l												
⑥	A	M	N	O	Ñ	Ò	Ó	Ô	Õ	Ö	Ø					
	a	m	n	o	ñ	ò	ó	ô	õ	ö	ø					
⑦	A	P	Q	R	S	ß										
	a	p	q	r	s	ß										
⑧	A	T	U	V	Ü	Ú	Û									
	a	t	u	v	ü	ú	û									
⑨	A	W	X	Y	Z											
	a	w	x	y	z											
⑩	A	[SP]														
	a															

**Note:** ① and ② keys are the same for English. Refer to the <Character Code For English (2/2)>.

<Number Code>

DIGIT KEY	CASE SHIFT	1st	2nd	3rd	4th	5th	6th	7th	8th	9th	10th	11th	12th	13th	14th	15th
①	□ 1	1														
②	□ 1	2														
③	□ 1	3														
④	□ 1	4														
⑤	□ 1	5														
⑥	□ 1	6														
⑦	□ 1	7														
⑧	□ 1	8														
⑨	□ 1	9														
⑩	□ 1	0														
⊕	□ 1	*	#	.	@	/	( )	,	-	_	:	'	~	&	\	
⊗	□ 1	Used as a case shift key. Shifts the characters between alphabetic and numeric.														

**Note:** When entering password, “0-9”, “\*” and “#” are available.

“#” is entered by pressing ⊕ key.

“\*” is entered by pressing ⊗ key.

## • Character Entry Method

As an example of character entry method, the following shows how to enter “Ken Kobus”.

STEP 1: Press **5** key twice to enter “K”.



STEP 2: Press the **Help** key or **Option** soft key to display Sub Menu screen, and then select **2 Word-case** to switch the text input mode from uppercase to lowercase.

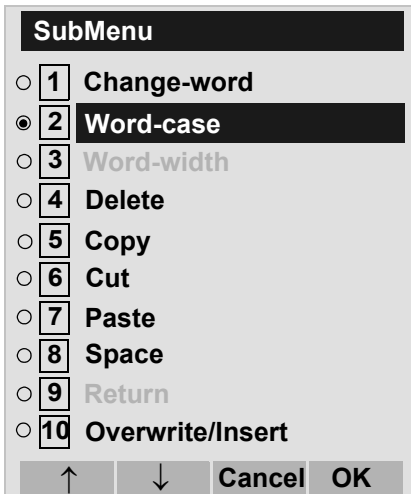

STEP 3: Press **OK** or the **OK** soft key on the Sub Menu to go back to text input screen.



STEP 4: Enter “en” by using digit keys.

Press **3** key twice to enter “e”.

Press **6** key twice to enter “n”.

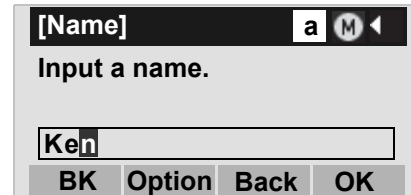

STEP 5: Press **0** key once to enter a space.

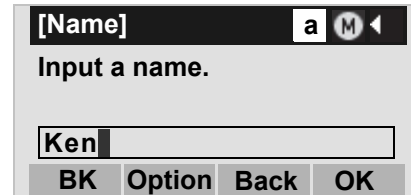

STEP 6: Press the **Help** key or **Option** soft key to display Sub Menu screen, and then select **2 Word-case** to switch the text input mode from lowercase to uppercase.



STEP 7: Press **OK** or the **OK** soft key on the Sub Menu to go back to text input screen.

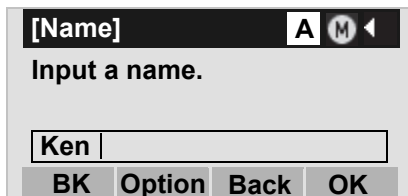

STEP 8: Press **5** key twice to enter "K".

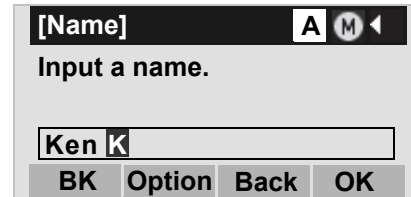

STEP 9: Press the **Help** key or **Option** soft key to display Sub Menu screen, and then select **2 Word-case** to switch the text input mode from uppercase to lowercase.

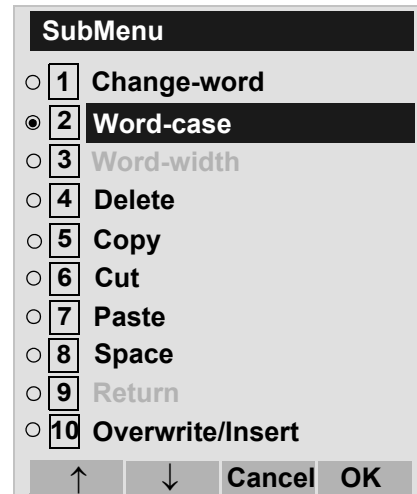



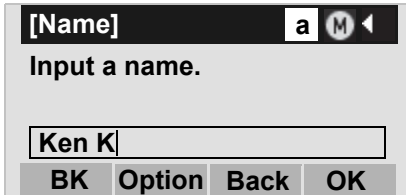

STEP 10: Press  or the **OK** soft key on the Sub Menu to go back to text input screen.



STEP 11: Enter "obus" by using digit keys.

Press  key three times to enter "o".

Press  key twice to enter "b".

Press  key twice to enter "u".

Press  key four times to enter "s".

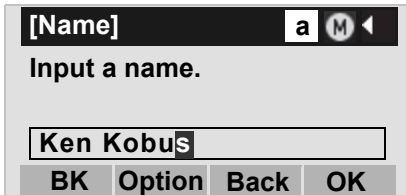



STEP 12: Press  or the **OK** soft key.

## • To Overwrite Characters

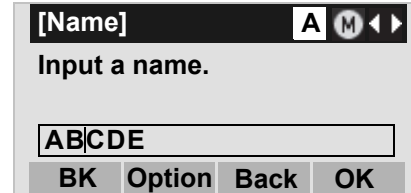
STEP 1: Place the cursor at the left of the characters to be overwritten.



STEP 2: Press the **Help** key or **Option** soft key.

STEP 3: On the following Sub Menu screen, select **10 Overwrite/Insert** and then press ,  or the **OK** soft key.



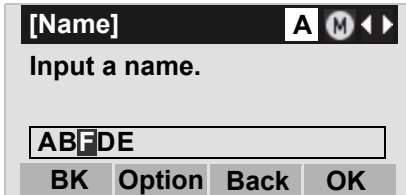

STEP 4: Enter new words over existing characters. In this example, "F" is entered.

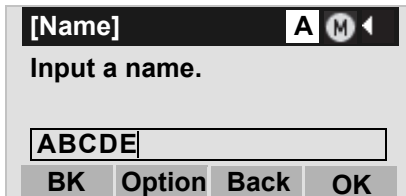

### • To Copy and Paste Characters

STEP 1: While characters which you want to copy are displayed, the **Help** key or **Option** soft key.



STEP 2: On the Sub Menu screen, press  or the **OK** soft key while **5 Copy** is highlighted, or press **5** key.



STEP 3: Place the cursor at the starting point of the target characters by using  and then press the **Start** soft key.

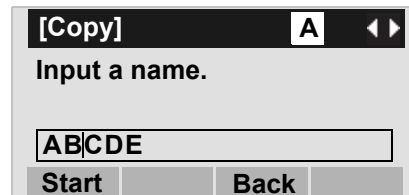

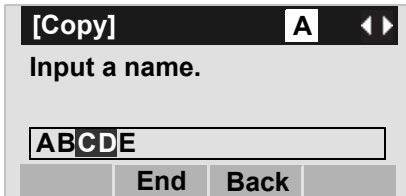

STEP 4: Place the cursor at the end point of the target characters  and then press the **End** soft key.

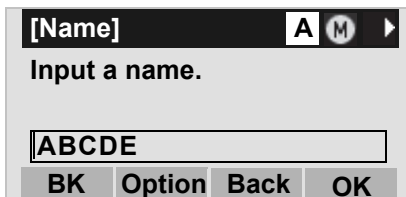

STEP 5: Place the cursor at position where you want to paste the copied characters and then press the **Help** key or **Option** soft key.



STEP 6: On the Sub Menu screen, select **7 Paste** and then press ,  or the **OK** soft key. (or press **7** key.)

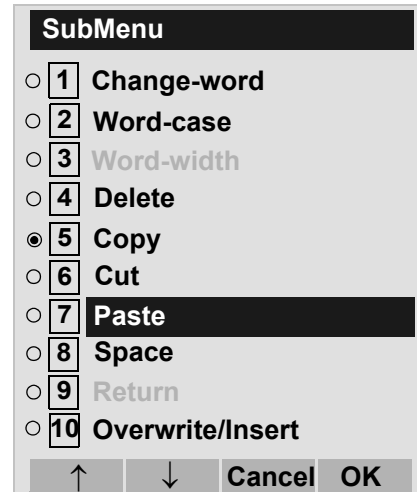

STEP 7: The copied characters “CD” are inserted as follows:

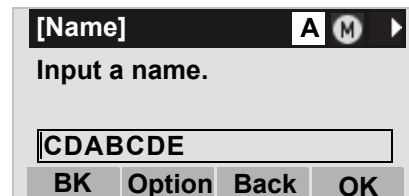

## SECURITY MODE **DT830**

By pressing the **Security** key, you can prevent information leakage from terminal. While the terminal is locked, Security Lamp lights up.

**Note:** The **Security** key must be programmed in advance. For the programming of the **Security** key, contact the system administrator.

**Note:** For using the feature of the terminal in collaboration with a mobile phone, the terminal cannot be placed in Security mode pressing the **Security** key. For details, contact the system administrator.

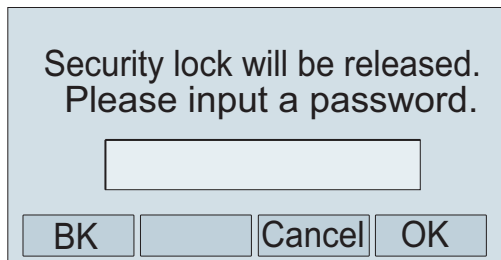

**Note:** When the system administrator invalidates the security mode, this function cannot be used. For details of the security mode, contact the system administrator.

**Note:** While the telephone is locked,  key becomes disabled. Also, any features provided by the Telephony Server, such as call origination or call answering, cannot be performed. (The Incoming call cannot be picked up though "Ringing" or "Voice call" are possible.) It is necessary to release the security mode to respond.

**Note:** To make a call of VOICE CALL is available toward a called party in the Security mode. When a called party activates the Security mode with leaving its Mic to ON, the called party can converse with a calling party though terminal operation is restricted.

**Note:** Even when the telephone is reset for any reason (such as power-off, etc.) while the telephone is placed in security mode, the lock is not released.

### • To Lock the Telephone

Before placing DT830 Series in Security mode, you can set a password. For details on the password setting, see [TO CHANGE PASSWORD](#) in chapter 3 Terminal Setup.

STEP 1: Press the **Security** key. The following message is displayed on LCD.

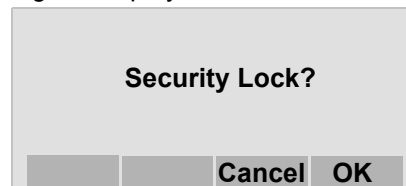

STEP 2: Press  or the **OK** soft key to place DT830 Series in Security mode.

STEP 3: When DT830 Series is placed in Security mode, Security Lamp lights red and the screen saver will be activated.

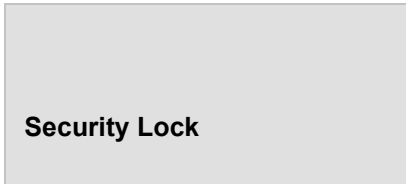



- **To Unlock the Telephone**

STEP 1: Display the Password Entry screen by either of the following operations.

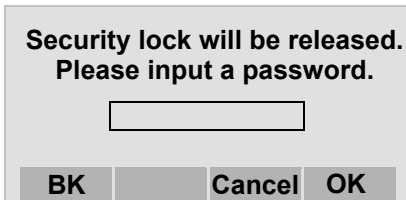
- Press any key while the screen saver is activated.
- Press the **Security** key while the screen saver is activated.



STEP 2: Enter the password and then press  or the **OK** soft key. Security Lamp is extinguished and Security Mode is canceled.

**Note:** When the password entry ends in failure, the following error message is issued. In that case, press  or the **OK** soft key and then retry.

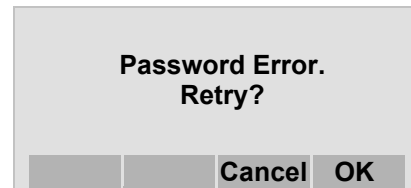

**Note:** After a third attempt (if incorrect password entered three times), the following error message is issued. Press  or the **OK** soft key. The telephone locks up, and any key operation will be disabled for 10 minutes. After 10 minutes, make a retry.

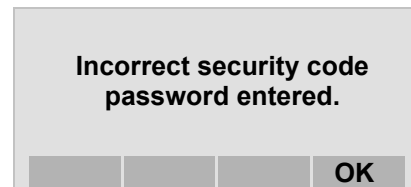

**Note:** If you forget the password, please contact the system administrator.

## EMERGENCY CALL **DT830**

You can make a call to a predetermined emergency telephone number while the telephone is locked (in Security mode). This function is available on the telephone with the **Security** key.

**Note:** You can make an emergency call to only the predetermined number. For details on the setting of the emergency number, contact the system administrator.

**Note:** When using Emergency Call, you can use the feature of the terminal in collaboration with a mobile phone until the terminal is placed in Security mode.

STEP 1: Lift the handset while the telephone is locked (the screen saver is activated).



**Dial Emergency Number Only**

**Unlock**

**Note:** Emergency Call cannot be made with the **Speaker** key.

**Note:** When pressing the **Unlock** soft key, the telephone prompts for the Security mode cancellation password.

STEP 2: Dial an emergency telephone number by pressing digit keys(0-9, \*, #).

**Note:** Emergency telephone number needs to be set in advance. For the setting of the emergency telephone numbers, contact the system administrator.

**Note:** You can make a call to only the predetermined number. When telephone numbers other than the predetermined emergency number are dialed, the following message appears (after a few seconds, the display goes back to "Dial Emergency Number Only" screen).



**Invalid Dial.**

**911**

STEP 3: After a conversation, replace the handset. The LCD turns to time display. Then, Security mode is released.

**Note:** If Security Lock is not set after originating an Emergency Call, Security Lock will be set after 60 minutes from releasing Security mode.

## XML APPLICATION **DT830**

DT830 has an XML browser function. You can display the information of XML application installed in an external server onto the LCD of DT830 and use various services in collaboration with the XML application.

Also, it is possible to launch multiple applications (up to 4 applications) simultaneously, and you can switch the screen quickly. If you receive an incoming call while displaying an application screen, you can answer the call without exiting the application. You can restart the suspended application by pressing an icon of itself.

The following explains how to start the XML application from DT830. For more information, refer to manuals relating to XML applications.

- **To start up XML application**

When you start up the phone, the application screen, which is registered as home URL, is displayed automatically.

- **To switch XML applications**

From the menu screen displays XML application icons, XML applications can be switched.

STEP 1: Press **Menu** key to display the menu screen.

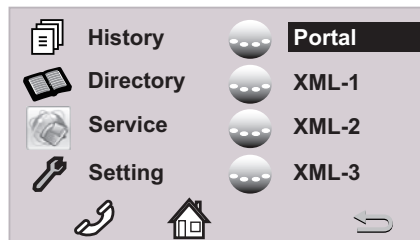

The icons of running XML applications are displayed on the menu screen.

STEP 2: Select an application icon you want to display on the menu screen.

- **To exit XML applications**

While an XML application screen is displayed, press **Exit** key to exit the application. After the XML application is exited, the icons of the running applications are aligned to the top of the Menu screen from the above.

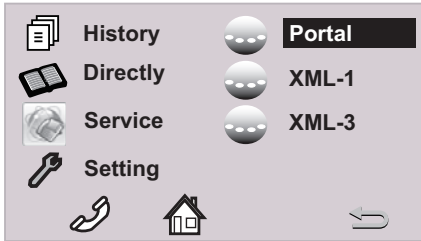

- **When a fifth application is launched**

You can launch up to four XML applications including Portal at a time. If you try to launch a fifth application, a notification message to ask you to exit one of the currently running applications is displayed.

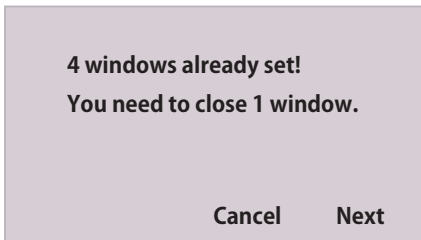

While this error message is displayed, you cannot execute any operations on XML applications.

**Note:** If you do not operate anything for 10 seconds after an error message is displayed, the trial of launching the new application is automatically canceled.

When you press the **Next** key, the application exit screen appears. On the exit screen, the currently running XML application icons excluding Portal are displayed. Select an application icon you want to exit and then press  icon.

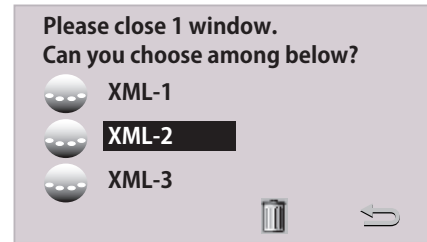

The selected application exits. Now, you can launch a new application.

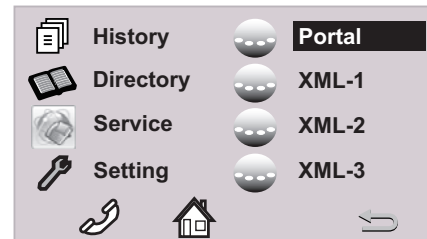



## SCREEN POP-UP **DT830**

When you receive an incoming call while an application screen (History, Directory, or XML application) is displayed, you can suspend the application and answer the incoming call.

- **To set the screen pop-up function**

STEP 1: Press **Menu** key to display the menu screen.  
Then, select **Setting**.

STEP 2: Select **1 User Setting**.

Select an item by one of the following operations.

- Highlight an item by using **UP/DOWN** soft key, and press **OK** soft key.
- Press **1** key.

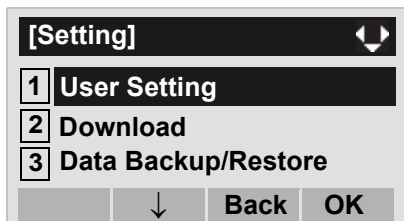

STEP 3: Select **7 Usability**.

Select an item by one of the following operations.

- Highlight an item by using **UP/DOWN** soft key, and press **OK** soft key.
- Press **7** key.

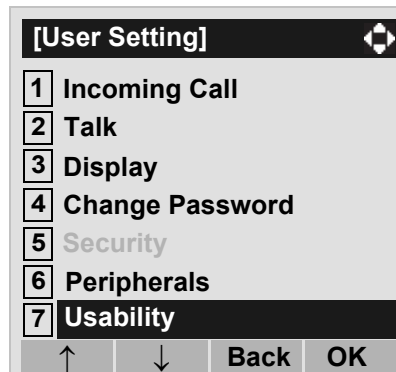

STEP 4: Select **1 Help Key Mode**.

Select an item by one of the following operations.

- Press **OK** soft key.
- Press **1** key.

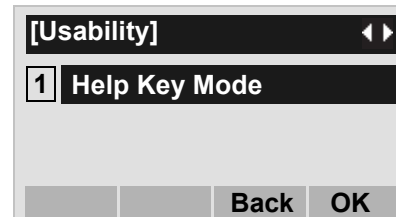

STEP 5: Select a desired mode of the **Help** key.

Select an item by one of the following operations.

- Highlight an item by using  or the **UP/DOWN** soft key, and press  or the **OK** soft key.
- Press **2** key, and press  or the **OK** soft key.

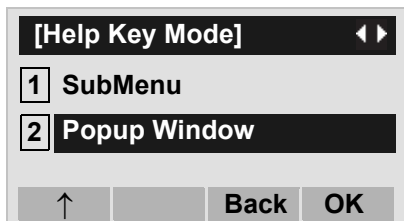



Menu Item	Meaning
1 Sub Menu	Set the <b>Help</b> key which displays sub menu
2 Popup Window	Set the <b>Help</b> key which displays pop-up window

### • To use the screen pop-up function

The following shows an example of an operation to display a pop-up screen when you receive an incoming call while an application screen is being displayed.

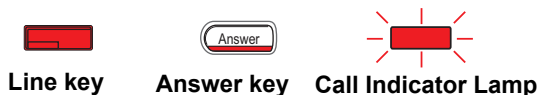

STEP 1: When you receive an incoming call while editing a name list on Directory Menu, call indicator lamp and line key flash red.

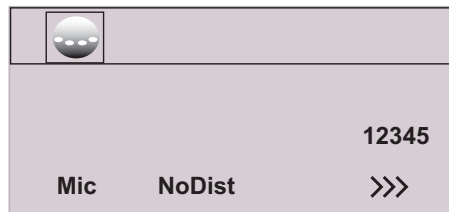

STEP 2: To open the pop-up screen and confirm incoming call number, when you set Help Key Mode as Sub Menu, press  key to display the menu screen and press the soft key 1. When you set Help Key Mode as Pop-up Window, press the **Help** key.

The screen is displayed and you can check the incoming call information.



To answer the incoming call, lift the handset. If you do not answer the call and continue to edit the name list of Directory, press  key to display the menu screen. And highlight Directory icon using , and then press  key.

**Note:** Pop-up screen cannot be closed by pressing the **Exit** key.

When you finish a conversation, hang up the handset. And you can go back to the screen of Directory.

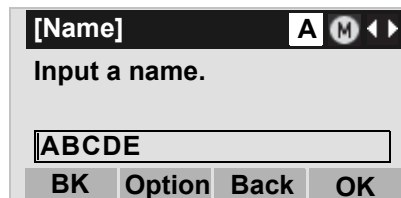

# 5. FEATURE OPERATION

## TO ORIGINATE A CALL USING SELECTIVE DIALING (DYNAMIC DIAL PAD, PRESET DIAL)

### Dynamic Dial Pad **DT830** **DT430/410**

STEP 1: Enter desired telephone number (Digit keys 0-9, \*, and #).

STEP 2: LED on **Speaker** key lights. Here the key touch tone.

STEP 3: The dialed number appears on the top of LCD.

	<b>2000</b>
<b>1:25 PM</b>	<b>MON 11 MAY 2015</b>
<b>Mic</b>	<b>&gt;&gt;&gt;</b>

**Note:** Pressing the **Speaker** key or going off-hook is not necessary.

### Preset Dial **DT830** **DT430/410**

**Note:** DTZ-2E-3 is not supported.

STEP 1: Enter desired telephone number (Digit keys 0-9, \*, and #).

STEP 2: The dialed number appears on the top of LCD.

<b>Input Dial Number</b>	<b>2000</b>
<b>Clr</b>	<b>Cnl</b>

STEP 3: Lift handset or press **Speaker** key.

**- OR -**

STEP 3: Press the originating Line key and lift the handset.

**Note:** Originating call operation is cancelled by the following soft key operation;

- Press the **Exit** key or the **Cnl** key.
- Press the **Clr** key, and cancel by one digit.

## TO ORIGINATE A CALL USING SPEED CALLING (ONE-TOUCH SPEED CALLING KEYS)

**DT830** **DT430/410**

STEP 1: Press the desired **One-Touch Speed Calling** key, or press **Speaker** key and **One-Touch Speed Calling** key.

### To Program

(Available only on the terminal with **One-Touch Speed Calling** key.)

STEP 2: Press **Feature** key.

STEP 3: Press the desired **One-Touch Speed Calling** key.

STEP 4: Enter the desired telephone number or feature access code on the keypad.  
Display indicates the digits dialed.

STEP 5: Press **Feature** key again to save the number.

<b>SPEED SET</b>		
1:25 PM MON 11 MAY 2015		
Mic	NoDist	>>>

### To Verify

STEP 2: Press **Feature** key.

STEP 3: Press the desired **One-Touch Speed Calling** key.

STEP 4: Display indicates digits programmed.

**Note:** To program a hook switch for transfer or feature activation, press **Recall** key as first digit. (! displays on LCD.)

**Note:** To program a pause, press the **Recall** key as any digit other than the first digit. (- displays on LCD.)

**Note:** To program a Voice Call, press **Transfer** key after dialing station number. (Voice displays on LCD.)

**Note:** The **One-Touch Speed Calling** key for feature access:

The **One-Touch Speed Calling** key may be used as a feature key by storing the feature access code. The features may be programmed on a system basis by the Telephony Server administrator. Access codes may be stored in conjunction with telephone numbers. For example, you can program one button to transfer to a certain extension.

### LCD Indication of DESI-less screen

STEP 1: Press the desired **One-Touch Speed Calling** key and originate a call.  
Registered name will be displayed as follows.  
For the key to which no name information is registered, the character "SPD" is displayed.

When a registering Name Information of One-touch Speed Calling, you can use uppercase alphabetic, uppercase European or lowercase European characters.

**Note:** For details of available characters, see TO REGISTER NAME ON ONE-TOUCH SPEED CALLING KEY.

## TO REGISTER NAME ON ONE-TOUCH SPEED CALLING KEY

**DT830 DT430**

(Available for DESI-less screen terminal.)

STEP 1: Press the **Name** soft key.

<p><b>Push Speed Calling Key</b>  <b>1:25 PM MON 11 MAY 2015</b>  <b>Name &gt;&gt;&gt;</b></p>
--

STEP 2: Press the desired **One-Touch Speed Calling** key.

STEP 3: Enter desired name on the keypad.  
 Display indicates the name entered.

<p><b>NEC BNET</b>  <sup>^</sup>  <b>Set Cnl Clr &gt;&gt;&gt;</b></p>
---

STEP 4: Press the **Set** soft key to save the name.

<p><b>1:25 PM MON 11 MAY 2015</b>  <b>Name &gt;&gt;&gt;</b></p>
---

**Note:** To delete the entry, press the **Delete** or the **BK** key and delete each one character.

**Note:** To delete the whole setting, press the **Clr** key and back to an idle state.

## To Register Speed Calling Number On DESI-less Screen

STEP 1: Follow the procedure of **To program** in **To Originate a Call Using Speed Calling (One-Touch Speed Calling Keys)**.

- Available characters for One-Touch Speed Calling keys.

### ALPHABETIC CHARACTER

DIGIT KEY	1	2	3	4	5	6	7	8	9	0	*	#
CHARACTER	1	A	D	G	J	M	P	T	W	0	*	#
		B	E	H	K	N	Q	U	X		@	&
		C	F	I	L	O	R	V	Y		.	(
		a	d	g	j	m	S	t	Z		,	)
		b	e	h	k	n	p	u	w		'	[
		c	f	i	l	o	q	v	x		:	]
		2	3	4	5	6	r	8	y		;	!
							s		z		-	?
							7		9		/	

### EUROPEAN CHARACTER (UPPERCASE)

DIGIT KEY	1	2	3	4	5	6	7	8	9	0	*	#
CHARACTER	.	A	D	G	J	M	P	T	W	0	*	#
	,	B	E	H	K	N	Q	U	X			
	:	C	F	I	L	O	R	V	Y			
	!	À	É	Ì	5	Ñ	S	Ù	Z			
	?	Á	Ê	Í		Ö	β	Ú	9			
	-	Ä	Ë	Ï		Ó	7	Û				
	+	Å	Ë	Ï		Ö		Ü				
	%	Ä	3	4		Ö		8				
	&	Å				Ö						
	/	Æ				Œ						
	(	Ç				Ø						
	)	2				6						
	=											
	¿											
¡												
1												

**Note:** The shaded area indicates the characters which cannot be entered.

### EUROPEAN CHARACTER (LOWERCASE)

DIGIT KEY	1	2	3	4	5	6	7	8	9	0	*	#
CHARACTER	.	a	d	g	j	m	p	t	w	0	*	#
	,	b	e	h	k	n	q	u	x			
	:	c	f	i	l	o	r	v	y			
	!	à	è	ì	5	ñ	s	ù	z			
	?	á	é	í		ò	β	ú	9			
	-	â	ê	î		ó	7	û				
	+	ã	ë	ï		ô		ü				
	%	ä	3	4		ö		8				
	&	å				ö						
	/	æ				œ						
	(	ç				ø						
	)	2				6						
	=											
	¿											
¡												
1												

**Note:** The shaded area indicates the characters which cannot be entered.

## TO ORIGINATE A CALL USING SPEED CALLING - STATION/GROUP

**DT830** **DT430/410**

**Note:** When Redial feature is enabled at installation, Last Number Redial feature and Speed Calling features using  (Redial) key are not available. For details, contact the system administrator.

STEP 1: Press  (Redial) key.

STEP 2: Press the desired speed calling number.

LNR[*]/SPD[_ _]	-X
	XXXXXX
Mic PickUp CF-All	>>>

## TO ORIGINATE A CALL USING SPEED CALLING - SYSTEM

**DT830** **DT430/410**

### To Program Speed Calling – System Key (On One-Touch Speed Calling Key)

STEP 1: Press  key.

STEP 2: Press the desired **One-Touch Speed Calling** key. The LCD displays previously stored digits.

STEP 3: Dial the “Speed Calling – System” access code and the abbreviated call code.

STEP 4: Press  key again.

<b>SPEED SET</b>
<b>1:25 PM MON 11 MAY 2015</b>

## To Operate From Speed Calling – System Key

STEP 1: Press the “Speed Calling – System” key.

XXXX
1:25 PM MON 11 MAY 2015

STEP 2: If the terminal does not have the “Speed Calling – System” key, dial the “Speed Calling – System” access code, then the abbreviated call code.

## To Operate From Directory Key

(Only DT410 Series equipped with a **Directory** key.)

STEP 1: Press **Directory** key.

STEP 2: Dial the abbreviated call code (maximum of 4 digits).

XXXX
1:25 PM MON 13 APR 2015

## ONE-TOUCH SPEED CALLING SETTING USING SPD SET KEY

**DT830** **DT430**

You can add, edit, or delete a **One-Touch Speed Calling** key using a programmable Line/Feature key or a **SPD Set** key. When using the **SPD Set** soft key, **One-Touch Speed Calling** can be set when the terminal in an off-hook state (idle), otherwise, it is invalid.

**Note:** A **SPD Set** key is available for SV9500 V2 or later.

**Note:** A **SPD Set** key is configured at the installation stage.

## To Add the One-Touch Speed Calling Key with SPD Set Key as New Data

STEP 1: Press the **SPD Set** key.

1:25 PM MON 11 MAY 2015
SPD Set Mic NoDist

STEP 2: Press the desired **One-Touch Speed Calling** key.

Push Speed Calling Key
1:25 PM MON 11 MAY 2015
SPD Set Mic NoDist

STEP 3: Enter the desired phone number (up to 32 digits can be registered).

Cnl	Clr	Set	>>>
		08211XX	



STEP 4: Press the **Regist** key. The following message appears for 3 seconds.

```
Entry is added!  
1:25 PM MON 11 MAY 2015  
SPD Set      Mic  NoDist
```

**Note:** During the registration operation, pressing any other key (**Exit**, **SPD Set**, or **Cnl**) cancels the setting. In that case, the terminal operates in accordance with the pressed key.

**Note:** When you receive an incoming call on the accommodated line while programming the **One-Touch Speed Calling** key, you can continue with the programming without answering the call. However, if you answer the call, the conversation will be started and the registration operation will be canceled.

**Note:** A new entry overwrites the previously saved phone number (the existing number temporarily displays when you try to set a new number).

## To Replace the Existing Data Assigned to a the One-Touch Speed Calling Key with New Data Using SPD Set Key

STEP 1: Press the **SPD Set** key.

```
1:25 PM MON 11 MAY 2015  
SPD Set      Mic  NoDist
```

STEP 2: Press the desired **One-Touch Speed Calling** key.

```
Push Speed Calling Key  
1:25 PM MON 11 MAY 2015  
SPD Set      Mic  NoDist
```

STEP 3: The phone number already registered is displayed. Press  key or the **Edit** soft key.

```
08211XX  
ReRegi Edit Delete
```

STEP 4: Enter the desired phone number (Up to 32 digits can be registered).

```
08211XX  
Cnl  Clr  Set  >>>
```

STEP 5: Press the **Regist** key. The following message appears for 3 seconds.

```
Entry is added!  
1:25 PM MON 11 MAY 2015  
SPD Set      Mic  NoDist
```

**Note:** During the registration operation, pressing any other key (**Exit**, **SPD Set**, or **Cnl**) cancels the setting. In that case, the terminal operates in accordance with the pressed key.



**Note:** When you receive an incoming call on the accommodated line while programming the **One-Touch Speed Calling** key, you can continue with the programming without answering the call. However, if you answer the call, the conversation will be started and the registration operation will be canceled.

**Note:** A new entry overwrites the previously saved phone number (the existing number temporarily displays when you try to set a new number).

## TO EDIT THE REGISTERED DATA

**DT830** **DT430**

### To Enter the Phone Number

STEP 1: Locate the cursor (underscore) with **LEFT/RIGHT** soft key (these soft keys are displayed pressing >>> soft key), or pressing  /  key.

STEP 2: Enter the desired phone number.

				08211XX_
Cnl	Clr	Set	>>>	

**Note:** If the entered number exceeds 24 digits, the digits following the 24th digit are displayed on the upper row of LCD. Phone number can be entered up to 32 digits.

### To Enter Hooking

STEP 1: Press the **Hook** soft key (this soft key is displayed pressing >>> soft key twice).

				_
Hook		Delete	>>>	

STEP 2: Hooking is indicated as “!” on the LCD.

				!_
Pause	Voice	Delete	>>>	

**Note:** The **Hook** soft key can be put only at the beginning of a number, and so “Hooking” sign (!) displays only before entering any number.

## To Enter Pause

STEP 1: Press the **Pause** soft key (this soft key is displayed pressing >>> soft key twice).

1234567890_			
Pause	Voice	Delete	>>>

STEP 2: Pause is indicated as “-” on the LCD.

1234567890- _			
Pause	Voice	Delete	>>>

**Note:** Up to three consecutive entries of the “Pause” sign (-) are allowed.

## To Enter Voice Call



STEP 1: Press the **Voice** soft key (this soft key is displayed pressing >>> soft key twice).

1234567890_			
Pause	Voice	Delete	>>>

STEP 2: Pause is indicated as “V” on the LCD.

1234567890V_			
Pause	Voice	Delete	>>>

## To Delete the Entered Character

STEP 1: Place the cursor (underscore) in front of the desired character (in this example, “2” is deleted) with **LEFT/RIGHT** soft key (these soft keys are displayed pressing >>> soft key), or pressing  / .

082_11XX			
Cnl	Clr	Set	>>>

STEP 2: Press the **Clr** soft key.

08_11XX			
Cnl	Clr	Set	>>>

## To Delete the Phone Number Data

STEP 1: Press the **Delete** soft key (this soft key is displayed pressing >>> soft key twice).

1234567890_			
Pause	Voice	Delete	>>>

STEP 2: Press the **OK** soft key.

Delete this entry?	
OK	Cnl

STEP 3: The following message appears for 3 seconds.

Entry is deleted			
1:25 PM MON 11 MAY 2015			
SPD Set		Mic NoDist	

**Note:** When this process ends in failure, “Delete Failed!” is displayed for 3 seconds on the LCD.

## To Delete the Number of One-Touch Speed Calling Keys Using SPD Set Key

STEP 1: Press the **SPD Set** key.

```
1:25 PM  MON 11 MAY 2015
SPD Set      Mic NoDist
```

STEP 2: Press the desired **One-Touch Speed Calling** key.

```
Push Speed Calling Key
1:25 PM  MON 11 MAY 2015
SPD Set      Mic NoDist
```

STEP 3: The phone number already registered is displayed. Press the **Delete** soft key.

```
                                08211XX
Set   Edit   Delete
```

STEP 4: Press the **OK** soft key.

```
Delete this entry?
                                OK   Cnl
```

STEP 5: The following message appears for 3 seconds.

```
Entry is deleted
1:25 PM  MON 11 MAY 2015
SPD Set      Mic NoDist
```

**Note:** When this process ends in failure, "Delete Failed!" is displayed for 3 seconds on the LCD.

## To Switch the Registering One-Touch Speed Calling Keys Using SPD Set Key

STEP 1: Press the **SPD Set** key.

```
1:25 PM  MON 11 MAY 2015
SPD Set      Mic NoDist
```

STEP 2: Press the desired **One-Touch Speed Calling** key.

```
Push Speed Calling Key
1:25 PM  MON 11 MAY 2015
SPD Set      Mic NoDist
```

STEP 3: The phone number already registered is displayed.

```
                                08211XX
ReRegi  Edit   Delete
```

STEP 4: Press another **One-Touch Speed Calling** key to switch the key data.

```
                                08211XX0
ReRegi  Edit   Delete
```

## ACCOUNT CODE **DT830** **DT430/410**

### To Enter

STEP 1: Lift the handset or press **Speaker** key, receive a dial tone.

STEP 2: Enter the feature access code, receive a service set tone.

STEP 3: Enter "Account Code" (up to 10 digits).

STEP 4: Receive a dial tone and dial the desired number.

**Note:** For North America, Account Codes can be up to 24 digits.

### To Enter Account Code After Authorization Code

STEP 1: Lift the handset or press **Speaker** key, receive a dial tone.

STEP 2: Enter the feature access code for "Authorization Code", receive a service set tone.

STEP 3: Enter the "Authorization Code", receive a second service set tone.

STEP 4: Enter the "Account Code", receive a dial tone, and dial the desired number.

**Note:** Authorization and Account Codes may be up to 20 digits combined (or 34 digits combined).

## FORCED ACCOUNT CODE

### **DT830** **DT430/410**

STEP 1: Lift the handset or press **Speaker** key, receive a dial tone.

STEP 2: Enter the feature access code, receive a service set tone.

STEP 3: Enter the "Forced Account Code" (up to 10 digits), receive a dial tone.

**Note:** For North America, Account Codes can be up to 24 digits. The total number of digits which can be entered for the Authorization and Account Codes is 34 digits.

## AUTHORIZATION CODE

### **DT830** **DT430/410**

### To Enter Without Account Code

STEP 1: Lift the handset or press **Speaker** key, receive a dial tone.

STEP 2: Enter the feature access code, receive a service set tone.

STEP 3: Enter the "Authorization Code" (up to 10 digits).

STEP 4: Receive a dial tone, dial the desired number.

- OR -

STEP 4: Lift the handset, receive a dial tone.

STEP 5: Dial the desired number.

STEP 6: If an "Authorization Code" is required, the caller hears a special dial tone.

STEP 7: Enter "Authorization Code", or call will be denied.

**Note:** This option is available only if system is programmed with Least Cost Routing.

### To Enter With Account Code (see above)

Service set tone is optional depending upon system programming.

**Note:** If a 4, 8, 16 or 32-button display terminal is used, the display indicates all of the digits dialed.

## VOICE CALL **DT830** **DT430/410**

STEP 1: Lift the handset.

STEP 2: Dial the desired station number.

STEP 3: Press the **Voice** key.

<b>VOICE</b> <b>2000</b> <b>1:25 PM MON 11 MAY 2015</b>
--

STEP 4: Speak to called party.

## Using Soft Key

STEP 1: Lift the handset.

STEP 2: Dial the desired station number; the **VOICE** soft key appears while the station is ringing.

<b>2000</b> <b>1:25 PM MON 11 MAY 2015</b> <b>Mic Voice &gt;&gt;&gt;</b>
--

STEP 3: Press the **VOICE** soft key and speak to called party.

**Note:** A Voice Call may be programmed on a **One-Touch Speed Calling** key by pressing the **One-Touch Speed Calling** key, dialing the extension, and pressing the **Transfer** key. (The **VOICE** key will display on LCD if it is programmed and saved on the terminal.)

**Note:** If called party is on their line when a Voice Call is attempted, calling station's display indicates as follows:

<b>VOICE BUSY</b> <b>1:25 PM MON 11 MAY 2015</b>
---

**Note:** A voice call is restricted if called party's station is not a DT Series. Display indicates as follows:

<b>VOICE REST</b> <b>1:25 PM MON 11 MAY 2015</b>
---

## TO ANSWER A VOICE CALL HANDS-FREE **DT830** **DT430/410**

- STEP 1: Receive an incoming Voice Call.
- STEP 2: Press the **Mic** soft key or  key. An LED lights.
- STEP 3: Respond the call with hands-free.

Calling station

<b>VOICE</b>	<b>2001</b>
<b>1:25 PM</b>	<b>MON 11 MAY 2015</b>

**Note:** If privacy is required, lift the handset.

## AUTOMATIC INTERCOM **DT830** **DT430/410**

### To Initiate

- STEP 1: Lift the handset or press  key.
- STEP 2: Press the **AICM** key.
- STEP 3: Hear a ringback tone.

Called party

<b>ICM</b>	<b>2</b>
<b>1:25 PM</b>	<b>MON 11 MAY 2015</b>

### To Answer

- STEP 1: The **AICM** key flashes red indicating an incoming intercom call.

Overriding party

<b>ICM</b>	<b>1</b>
<b>1:25 PM</b>	<b>MON 11 MAY 2015</b>

- STEP 2: Press the **AICM** key, lift the handset or press  key, the LED lights solid green.

**Note:** When the called station is engaged with a non-intercom call, the called station user presses the **AICM** key to answer the incoming call after placing the non-intercom caller on hold (with  key).

## To Bridge Into An Automatic Intercom Call

**Note:** Bridging is an optional feature.

STEP 1: Press the **AICM** key, lift the handset or press  key.

Overriding party

<b>OVERRIDE</b>	<b>1</b>
<b>1:25 PM MON 11 MAY 2015</b>	

STEP 2: A three-party conference is established.

<b>CONF</b>	
<b>1:25 PM MON 11 MAY 2015</b>	

## MANUAL INTERCOM

**DT830 DT430/410**

### To Initiate

STEP 1: Press the **MICM** key, lift the handset or press  key, a ringback tone is heard.

STEP 2: Press the **SIG** key if it is desired for the called station to hear ringing.

Called party

<b>ICM</b>	<b>2</b>
<b>1:25 PM MON 11 MAY 2015</b>	

### To Answer

STEP 1: The **MICM** key flashes, indicating an incoming call. A ring tone may also be heard.

Calling party

<b>ICM</b>	<b>1</b>
<b>1:25 PM MON 11 MAY 2015</b>	

STEP 2: Press the **MICM** key.

STEP 3: Lift the handset or press  key, the LED lights solid green.

**Note:** When the called station is engaged with a non-intercom call, the called station user presses the **MICM** key to answer the incoming call after placing the non-intercom caller on hold (with  key).



## To Bridge Into A Manual Intercom Call

**Note:** Bridging is an optional feature.

STEP 1: Press the **MICM** key, lift the handset or press the **Speaker** key.

Overriding party

<b>OVERRIDE</b>	<b>1</b>
<b>1:25 PM MON 11 MAY 2015</b>	

STEP 2: A three-party conference is established.

<b>CONF</b>	
<b>1:25 PM MON 11 MAY 2015</b>	

**Note:** The **SIG** key signals the corresponding station when speaking over the intercom path is unnecessary.

**Note:** Two-button Manual Intercom provides one button for signaling and one for talking. A separate signaling button can be used in many ways for the secretary to alert a boss, or vice versa.

## DIAL INTERCOM **DT830** **DT430/410**

### To Initiate

STEP 1: Lift the handset or press the **Speaker** key.

STEP 2: Press the **DICM** key.

STEP 3: Dial the desired intercom station number. Receive a ringback tone.

Called party

<b>ICM</b>	<b>2</b>
<b>1:25 PM MON 11 MAY 2015</b>	

### To Answer

STEP 1: The **DICM** key flashes, indicating an incoming intercom call.

STEP 2: Press the **DICM** key.

STEP 3: Lift the handset or press the **Speaker** key. The LED lights solid green.

Calling party

<b>ICM</b>	<b>2</b>
<b>1:25 PM MON 11 MAY 2015</b>	

**Note:** When the called station is engaged with a non-intercom call, the called station user presses the **DICM** key to answer the incoming call after placing the non-intercom caller on hold (with **HOLD** key).

## To Bridge Into A Dial Intercom Call

**Note:** Bridging is an optional feature.

STEP 1: Press the **DICM** key, lift handset or press  key.

Overriding party

<b>VERRIDE</b>	<b>3</b>
<b>1:25 PM MON 11 MAY 2015</b>	

STEP 2: A three-party conference is established.

<b>CONF</b>
<b>1:25 PM MON 11 MAY 2015</b>

**Note:** Dial intercom provides a Dial Intercom group where each member of the group may be called by a 1-digit or 2-digit number without using their prime lines.

## CONFERENCE

STEP 1: With a call in progress, press  key and dial desired number.

STEP 2: After call is answered, press the **Conf.** soft key. Three-way conference is established.

<b>CONF</b>
<b>1:25 PM MON 11 MAY 2015</b>
<b>Mic &gt;&gt;&gt;</b>

STEP 3: If one party hang up, other two remain connected. The **Conf** key's LED goes out.

**Note:** The Conf key is accommodated on only DTZ-2E-3 and DTZ-6DE-3. If using the terminals without  key, use a soft key or programmable feature key to which conference feature has been assigned.

## TO SWITCH A CALL WITH TRANSFER KEY

STEP 1: While engaged in a call and wishing to consult a third party, press  key. The original caller is automatically placed on hold.

STEP 2: Dial desired party to consult.

STEP 3: Press  key to return to original caller. Third party is automatically placed on hold.

STEP 4: By repeating these steps, it is possible to alternate between calls. The display indicates connected station or trunk any given time.

## TO ANSWER A CAMPED-ON CALL

### DT830 DT430/410

- STEP 1: While engaged in a call, receive the camp-on indication (one short tone burst). LED of **Answer** key flashes.
- STEP 2: Press **Answer** key. Call in progress is placed on hold.
- STEP 3: Connection to camped-on call is established.
- STEP 4: Press **Answer** key to return to original call. Camped-on call is placed on hold.
- STEP 5: By repeating these steps, it is possible to alternate between calls. The display indicates connected station or trunk at any given time.

	Trunk type	Trunk number
<b>CAMP ON</b>	<b>DDD</b>	<b>3</b>
<b>1:25 PM</b>	<b>MON 11 MAY 2015</b>	

## CALL WAITING - ORIGINATING

### DT830 DT430/410

#### To Program Call Waiting Key (On One-Touch Speed Calling Key)

- STEP 1: Press **Feature** key.
- STEP 2: Press the desired **One-Touch Speed Calling** key.
- STEP 3: Press **Recall** key, “!” appears on the LCD.
- STEP 4: Dial the “Call Waiting” feature access code.
- STEP 5: Press **Feature** key.

**Note:** To program a hook switch for transfer or feature activation, press **Recall** as first digit. “!” displays on LCD.

#### To Activate Call Waiting – Originating

- STEP 1: Dial the desired station number, receive a busy tone.
- STEP 2: Press the **CALL WAITING** key.
- STEP 3: Receive a special ringback tone.

STEP 4: The Call Waiting tone is sent to busy station.

Called station  
number

<b>C WAIT</b>	<b>2000</b>
<b>1:25 PM MON 11 MAY 2015</b>	
<b>Mic CallBack</b>	<b>&gt;&gt;&gt;</b>

– OR –

STEP 4: Lift the handset or press **Speaker** key.

STEP 5: Dial the “Call Waiting” access code, receive a dial tone.

<b>C WAIT</b>	
<b>1:25 PM MON 11 MAY 2015</b>	
<b>Mic CallBack</b>	<b>&gt;&gt;&gt;</b>

STEP 6: Dial the busy station.

<b>C WAIT SET</b>	<b>2000</b>
<b>1:25 PM MON 11 MAY 2015</b>	
<b>CallWait</b>	

## Using Soft Key

STEP 1: Dial the desired station and receive a busy tone.

STEP 2: Press the **CallWait** soft key receive a call waiting ringback tone.

Called station  
number

<b>C WAIT SET</b>	<b>2000</b>
<b>1:25 PM MON 11 MAY 2015</b>	
<b>Mic</b>	<b>&gt;&gt;&gt;</b>

## To Answer A Waiting Call

STEP 1: A Call Waiting Tone is heard.

STEP 2: Press **Answer** key.

STEP 3: The waiting call is automatically connected. Original party is placed on hold.

STEP 4: By repeatedly pressing **Answer** key, it is possible to alternate between calls. Display indicates connected station or trunk at any given time.

Calling station  
number

<b>C WAIT</b>	<b>2001</b>
<b>1:25 PM MON 11 MAY 2015</b>	

## Using Soft Key

STEP 1: Hear burst of tone Display indicates “C WAIT” and **Answer** key flashes.

STEP 2: Press **Answer** key receive call waiting tone.

Calling station  
number

<b>C WAIT</b>	<b>2001</b>
<b>1:25 PM MON 11 MAY 2015</b>	
<b>Mic</b>	<b>&gt;&gt;&gt;</b>

## To Disconnect

STEP 1: Press **Recall** key. Station user is automatically connected to original party.

## CALL PARK **DT830** **DT430/410**

### To Program Call Park Key (On One-Touch Speed Calling Key)

STEP 1: Press **Feature** key.

STEP 2: Press the **One-Touch Speed Calling** key.

STEP 3: Press **Recall** key. “!” displays on LCD.

STEP 4: Dial the “Call Park” access code.

STEP 5: Press **Feature** key again.

### To Park A Call

STEP 1: While connected to a station or trunk, press the **CALL PARK**.

Parked station  
or trunk

<b>CALLPARK SET</b>	<b>DDD 3</b>
<b>1:25 PM MON 11 MAY 2015</b>	

## To Retrieve A Parked Call From Originating Station

STEP 1: Dial the “Call Park” local retrieval code.

STEP 2: A Station user is connected to parked call.

Elapsed time

<b>10:01</b>	<b>DDD 2</b>
<b>1:25 PM</b>	<b>MON 11 MAY 2015</b>

## To Retrieve A Parked Call From A Remote Station

STEP 1: Dial the “Call Park” local retrieval code.

STEP 2: A Station user is connected to parked call.

Station that parked the call

<b>2000</b>	<b>DDD 2</b>
<b>1:25 PM</b>	<b>MON 11 MAY 2015</b>

## CALL PICK-UP (GROUP)

**DT830** **DT430/410**

### When Station Within Pick-up Group Rings

STEP 1: Lift the handset.

STEP 2: Press the **CALL PICK-UP** or dial the “Call Pick-up” access code (may be stored on the **One-Touch Speed Calling** key).

STEP 3: Connection to calling party is established.

STEP 4: If currently on a call, press **Transfer** key and dial the “Call Pick-up” access code. The original party is placed on hold.

	Called station	Calling party
<b>PICK UP</b>	<b>2000 DDD</b>	<b>3</b>
<b>1:25 PM</b>	<b>MON 11 MAY 2015</b>	

### Using Soft Key

STEP 1: Lift the handset and press the **PickUp** soft key.

STEP 2: Connection to calling party is established.

	Called station	Calling party
<b>PICK UP</b>	<b>2000</b>	<b>2001</b>
<b>1:25 PM</b>	<b>MON 11 MAY 2015</b>	
<b>Mic</b>		<b>&gt;&gt;&gt;</b>

## CALL PICK-UP (DIRECT)

**DT830** **DT430/410**

### To Program Pick-up Direct Key (One-Touch Speed Calling Key)

- STEP 1: Press **Feature** key.
- STEP 2: Press the **One-Touch Speed Calling** key.
- STEP 3: Dial the “Direct Call Pick-up” access code.
- STEP 4: Press **Feature** key again.

### When A Station Within System Rings

- STEP 1: Lift the handset, receive a dial tone.
- STEP 2: Press the **PICK-DIRECT** key and dial the station number to be picked up.

– OR –

- STEP 2: Dial the “Direct Call Pick-up” access code and the station number to be picked up.
- STEP 3: Connection to calling party is established.
- STEP 4: If busy, the original call must be placed on hold before new call can be picked up.

	Called station	Calling party
<b>PICK UP</b>	<b>2000 DDD</b>	<b>3</b>
<b>1:25 PM</b>	<b>MON 11 MAY 2015</b>	

## OUTGOING TRUNK QUEUING

**DT830** **DT430/410**

### If Trunk Is Busy

- STEP 1: Receive Trunk Busy indication. Press the **CALL BACK** key, Call is placed in queue for next available trunk.
- STEP 2: When trunk is available, the setting station is alerted by ringing and flashing red LED.
- STEP 3: Press **Speaker** key or lift the handset. A dial tone is heard or number is automatically dialed if Least Cost Routing is provided.

**OG-Q SET**  
**1:25 PM MON 11 MAY 2015**

## OFF-HOOK TRUNK QUEUING

**DT830** **DT430/410**

- STEP 1: Press **Speaker** key, receive a dial tone.
- STEP 2: Dial desired telephone number. Encounter a trunk busy condition.
- STEP 3: A station user receives a service set tone and leaves speaker on.
- STEP 4: The desired number is automatically dialed when a trunk becomes available.

## EXECUTIVE OVERRIDE

**DT830** **DT430/410**

### If Called Station Is Busy

STEP 1: Press the **VERRIDE** key.

STEP 2: Interrupted parties receive a warning tone.

Overridden station

<b>VERRIDE</b>	<b>2001</b>
<b>1:25 PM</b>	<b>MON 11 MAY 2015</b>

STEP 3: Three-way conference is initiated.

<b>CONF</b>	
<b>1:25 PM</b>	<b>MON 11 MAY 2015</b>

**Note:** The **Conf** key is accommodated on only DTZ-2E-3 and DTZ-6DE-3.

### Using Soft Key

STEP 1: Press the **Exe-Over** soft key.

STEP 2: Interrupted parties receive a warning tone and three-way conference is initiated.

<b>VERRIDE</b>	<b>2001</b>
<b>1:25 PM</b>	<b>MON 11 MAY 2015</b>
<b>Mic</b>	<b>&gt;&gt;&gt;</b>

**Note:** Override may be programmed by the Telephony Server administrator for one of the Programmable feature keys, or may be programmed on a **One-Touch Speed Calling** key by storing the Recall and Override access code.



## REDIAL

**DT830 DT430/410**

**Note:** When Redial feature is enabled at installation, Last Number Redial feature and Speed Calling features using  (Redial) key are not available. For details, contact the system administrator.



### To Redial the Last Number Dialed

STEP 1: Press  (Redial) key. A last number dialed is displayed.

Redial	01
	XXXXX1
↑	↓
Delete	End

STEP 2: Press  or the **UP/DOWN** soft key until desired number is displayed. Up to 20 previously dialed numbers are available.

Redial	02
	XXXXX2
↑	↓
Delete	End

STEP 3: Go off-hook or press  key,  or the **OK** soft key to make a call to the displayed party.

STEP 4: When party has answered, lift the handset or speak hands-free.

### To Delete the One Call History Data of Outgoing Call

STEP 1: Press  (Redial) key. A last number dialed is displayed.

Redial	01
	XXXXX1
↑	↓
Delete	End

STEP 2: Press  or the **UP/DOWN** soft key until desired number is displayed.

Redial	02
	XXXXX2
↑	↓
Delete	End

STEP 3: Press the **Delete** soft key.

STEP 4: Press the **One** soft key.

Redial	02
	XXXXX2
One	All
	Cnl

## To Delete the All Call History Data of Outgoing Call

STEP 1: Press  (Redial) key. A last number dialed is displayed.

Redial	01
	XXXXX1
↑      ↓      Delete	End

STEP 2: Press the **Delete** soft key.

STEP 3: Press the **All** soft key.

Redial	01
	XXXXX1
One      All	Cnl

## LAST NUMBER REDIAL

**DT830** **DT430/410**

**Note:** When Redial feature is enabled at installation, Last Number Redial feature and Speed Calling features using  (Redial) key are not available. For details, contact the system administrator.

## To Recall Last Number Dialed

STEP 1: Press  (Redial) key. The last number dialed is displayed.

LNR[*]/SPD[_ _]	-X
	XXXXXX
Mic      PickUp      CF-All	>>>

STEP 2: Press  (Redial) key until the desired number is displayed. Up to 5 previously dialed numbers.

STEP 3: Press ✖ (**Note 1**, **Note 2**). The number on the display is automatically redialed.

STEP 4: When the party has answered, lift the handset or speak hands-free.

**Note1:** A-law Countries [Europe, Australia, Russia, Latin America, Middle Near East, other Asian nations]: #  
μ-law Countries [North America]: ✖

**Note2:** The key to redial (#, ✖) can be changed by the system setting. For details, contact the system administrator.

## CALL FORWARDING - ALL CALLS

**DT830** **DT430/410**

### To Set

- STEP 1: Press **Speaker** key. Receive a dial tone.
- STEP 2: If the setting for another station, press the **MULTILINE APPEARANCE** feature key.
- STEP 3: Press the **FWD** key or dial “Call Forwarding – All Calls” access code. Receive a special dial tone.
- STEP 4: Dial the destination station or the external telephone number. Receive a service set tone.
- STEP 5: The **FWD** key’s LED lights (at your station or at the terminal of the multiline station you are setting).
- STEP 6: Press **Speaker** key. Call Forwarding – All Calls is set.

Forwarding  
station

<b>FORWARD SET</b>	<b>2000</b>
<b>1:25 PM</b>	<b>MON 11 MAY 2015</b>

### Using Soft Key

- STEP 1: Press the **CF-All** soft key. Receive a special tone.
- STEP 2: Dial the destination; wait for a service set tone.
- STEP 3: “**FORWARD SET**” is displayed, call forwarding for all calls is set.

<b>FORWARD SET</b>
<b>1:25 PM MON 11 MAY 2015</b>
<b>Mic &gt;&gt;&gt;</b>

### To Verify (Only For Terminal With LCD)

- STEP 1: Press the **FWD** key.
- STEP 2: The display indicates the station number calls are forwarded to.

Forwarding  
station

<b>FORWARD</b>	<b>2000</b>
<b>1:25 PM</b>	<b>MON 11 MAY 2015</b>

**Note:** With soft key operation, the **CF-All** lights on the display.

## To Cancel

- STEP 1: Press **Speaker** key. Receive a dial tone. If canceling for another station, press the **MULTILINE APPEARANCE** feature key.
- STEP 2: Press the **FWD** key or dial “Call Forwarding – All Calls” cancel code. Receive a service set tone. LED goes out at your station (or the terminal of the multiline station).
- STEP 3: Press **Speaker** key. Call Forwarding – All Calls is cancelled.

**FORWARD CANCEL**  
1:25 PM MON 11 MAY 2015

## Using Soft Key

- STEP 1: Press the **CF-All** soft key.
- STEP 2: Receive a service set tone and “**FORWARD CANCEL**” is displayed.

**FORWARD CANCEL**  
1:25 PM MON 11 MAY 2015  
Mic >>>

## CALL FORWARDING - BUSY LINE

**DT830 DT430/410**

### To Set

- STEP 1: Press **Speaker** key. Receive a dial tone.
- STEP 2: If setting for another station, press the **MULTILINE APPEARANCE** feature key.
- STEP 3: Press the **FWD-BY** key or dial “Call Forwarding – Busy Line” access code. Receive a special dial tone.
- STEP 4: Dial the destination station or the external telephone number. Receive a service set tone.
- STEP 5: The **FWD-BY** key’s LED lights (at your station or at the terminal of the multiline station you are setting).
- STEP 6: Press **Speaker** key. Call Forwarding – Busy Line is set.

**FORWARD SET**  
1:25 PM MON 11 MAY 2015

## Using Soft Key

- STEP 1: Press the **CF-Busy** soft key. Receive a special dial tone.
- STEP 2: Dial the destination; wait for a service set tone.
- STEP 3: “**FORWARD SET**” is displayed; Call Forwarding – Busy Line is set.

<b>FORWARD SET</b> 1:25 PM MON 11 MAY 2015 Mic >>>
--

## To Verify (Only For Terminal With LCD)

- STEP 1: Press the **FWD-BY** key.
- STEP 2: The display indicates the station number calls are forwarded to.

Forwarding station

<b>FORWARD</b> 2000 1:25 PM MON 11 MAY 2015
--

**Note:** With soft key operation, the **CF-Busy** flashes on the display.

## To Cancel

- STEP 1: Press **Speaker** key. Receive a dial tone. If canceling for another station, press **MULTILINE APPEARANCE** feature key.
- STEP 2: Press the **FWD-BY** key or dial “Call Forwarding – Busy Line” cancel code. Receive service set tone. LED goes out at your station (or the terminal of the multiline station).
- STEP 3: Press **Speaker** key. Call Forwarding – Busy Line is cancelled.

<b>FORWARD CANCEL</b> 1:25 PM MON 11 MAY 2015
--

## Using Soft Key

- STEP 1: Press the **CF-Busy** soft key.
- STEP 2: Receive a service set tone and “**FORWARD CANCEL**” is displayed.

<b>FORWARD CANCEL</b> 1:25 PM MON 11 MAY 2015 Mic >>>
---

## CALL FORWARDING - DON'T ANSWER

**DT830** **DT430/410**

### To Set

- STEP 1: Press **Speaker** key. Receive a dial tone.
- STEP 2: If setting for another station, press the **MULTILINE** feature key.
- STEP 3: Press the **FWD-NA** key or dial “Call Forwarding – Don’t Answer” access code. Receive a special dial tone.
- STEP 4: Dial the destination station or the external telephone number. Receive a service set tone.
- STEP 5: The **FWD-NA** key’s LED lights (at your station or at the terminal of the multiline station you are setting).
- STEP 6: Press **Speaker** key. Call Forwarding – Don’t Answer is set.

Forwarding  
station

<b>FORWARD SET</b>	<b>2000</b>
<b>1:25 PM</b>	<b>MON 11 MAY 2015</b>

### Using Soft Key

- STEP 1: Press the **CF-NoAns** soft key. Receive a special dial tone.
- STEP 2: Dial the destination; wait for a service set tone.
- STEP 3: “**FORWARD SET**” is displayed; Call Forwarding – Don’t Answer is set.

<b>FORWARD SET</b>
<b>1:25 PM</b> <b>MON 11 MAY 2015</b>
<b>Mic</b> <b>&gt;&gt;&gt;</b>

### To Verify (Only For Terminal With LCD)

- STEP 1: If verifying for another station, press the **MULTILINE** feature key while an idle state.
- STEP 2: Press the **FWD-NA** key.
- STEP 3: The display indicates the station number calls are forwarded to.

Forwarding  
station

<b>FORWARD</b>	<b>2000</b>
<b>1:25 PM</b>	<b>MON 11 MAY 2015</b>

**Note:** Call Forwarding for Busy Line and Don't Answer may be combined depending upon system programming.

**Note:** With soft key operation, the **CF-NoAns** flashes on the display.

## To Cancel

- STEP 1: Press **Speaker** key. Receive dial tone. If canceling for another station, press **MULTILINE APPEARANCE** feature key.
- STEP 2: Press the **FWD-NA** key or dial “Call Forwarding - Don't Answer” cancel code. Receive service set tone. LED goes out at your station (or the terminal of the multiline station).
- STEP 3: Press **Speaker** key. Call Forwarding – Don't Answer is cancelled.

**FORWARD CANCEL**  
1:25 PM MON 11 MAY 2015

## LOGGED OUT IP STATION - CALL DESTINATION **DT830**

### To Set

- STEP 1: Lift handset or press **Speaker** key.
- STEP 2: Press the **CFLLogout** key or dial “Logged Out IP Station – Call Destination” access code.
- STEP 3: Dial the destination station number; receive a service set tone.
- STEP 4: Replace the handset or press **Speaker** key. Logged Out IP Station – Call Destination is set.

**FORWARD SET** **XXXX**  
1:25 PM MON 11 MAY 2015

### Using Soft Key

- STEP 1: Press the **CFLLogout** soft key; receive a special Dial Tone.
- STEP 2: Dial the destination station number.
- STEP 3: Receive a service set tone; “**FORWARD SET**” is displayed

**FORWARD SET** **XXXX**  
1:25 PM MON 11 MAY 2015  
Mic >>>

## To Verify (Only For Terminal with LCD)

STEP 1: Press “Logged Out IP Station – Call Destination” feature key lit red or press the **CFLogout** soft key.

STEP 2: The display indicates the station number calls are forwarded.

<b>FORWARD</b>	<b>XXXX</b>
<b>1:25 PM</b>	<b>MON 11 MAY 2015</b>

**Note:** With soft key Operation, the **CFLogout** flashes on the display.

## To Cancel

STEP 1: Lift the handset or press **Speaker** key; receive a Dial Tone.

STEP 2: Press the **CFLogout** key or dial “Logged Out IP Station – Call Destination” cancel code; receive service set tone.

STEP 3: Replace the handset or press **Speaker** key. Logged Out IP Station – Call Destination is canceled.

<b>FORWARD CANCEL</b>
<b>1:25 PM</b> <b>MON 11 MAY 2015</b>

## Using Soft Key

STEP 1: Lift the handset or press **Speaker** key; receive a Dial Tone.

STEP 2: Press the **CFLogout** soft key; receive a service set tone.

STEP 3: Dial the destination station number; receive a service set tone.

STEP 4: “Logged Out IP Station – Call Destination” lamp goes off and CFLogout indication disappears on the LCD.

<b>FORWARD CANCEL</b>
<b>1:25 PM</b> <b>MON 11 MAY 2015</b>
<b>Mic</b> <span style="float: right;">&gt;&gt;&gt;</span>



## CALL BACK **DT830** **DT430/410**

### If Called Station is Busy

STEP 1: Press the **CALL BACK** key. Receive a service set tone.

Called party

<b>CALLBACK SET</b>	<b>2000</b>
<b>1:25 PM</b>	<b>MON 11 MAY 2015</b>

– OR –

STEP 1: Press the **Flash** key and enter “Call Back” access code.

STEP 2: When both parties become an idle state, calling party's phone rings. Calling party would go off hook and hear ring back tone. The called station would then be ringing.

Called party

<b>CALLBACK</b>	<b>2000</b>
<b>1:25 PM</b>	<b>MON 11 MAY 2015</b>

STEP 3: The connection is established when the called party answers.

Called party

<b>CALLBACK</b>	<b>2001</b>
<b>1:25 PM</b>	<b>MON 11 MAY 2015</b>

**Note:** Call Back may be programmed by the Telephony Server administrator on a Programmable feature key or by the user on a **One-Touch Speed Calling** key.

### Using Soft Key

STEP 1: Press the **CallBack** soft key and receive a service set tone.

STEP 2: “**CALLBACK SET**” is displayed and the **Call-Back** soft key flashes on the display.

<b>CALLBACK SET</b>
<b>1:25 PM</b> <b>MON 11 MAY 2015</b>
<b>Mic</b> <span style="float: right;">&gt;&gt;&gt;</span>

## TO SAVE AND REPEAT A NUMBER

### **DT830** **DT430/410**

#### To Save

STEP 1: Press **Speaker** key.

STEP 2: Dial the desired telephone number.

STEP 3: Press the **Save&Rep** key. The dialed number is now stored. The **Save&Rep** key's LED lights.

– OR –

STEP 3: Receive an internal call.

STEP 4: Press the **Save&Rep** key. The number is stored in memory.

STEP 5: The **Save&Rep** key's LED lights.

## Using Soft Key

- STEP 1: Press the **Save&Rep** key. The number is stored in memory.
- STEP 2: The **Save&Rep** key's LED lights.

## To Verify (Only For Terminal With LCD)

- STEP 1: While an idle state, press the **Save&Rep** key.
- STEP 2: The display indicates digits sorted.

## To Repeat

- STEP 1: Press **Speaker** key.
- STEP 2: Press the **Save&Rep** key. The terminal automatically redials the programmed number.
- STEP 3: The **Save&Rep** automatically cancelled. LED goes out.

**Note:** If saved number is busy or no answer is received, to save it again, press the **Save&Rep** key again before hanging up.

## Using Soft Key

- STEP 1: Press flashing the **Save&Rep** soft key. Stored number is automatically redialed. "**Save&Rep**" disappears from display.

## TO LEAVE A MESSAGE

**DT830 DT430/410**

- STEP 1: Press **Speaker** key. Receive a dial tone.
- STEP 2: Dial the desired station number. Encounter no answer or busy condition.
- STEP 3: Press the **MSG** key. The message is sent to called the terminal.
- STEP 4: The called station **MSG** LED lights.

Called station

<b>MESSAGE SET</b>	<b>2001</b>
<b>1:25 PM</b>	<b>MON 11 MAY 2015</b>

**Note:** Up to four messages can be stored in the terminal memory.

**Note:** If a fifth message is attempted, a reorder tone is heard and the display indicates as follows:

<b>MESSAGE BUSY</b>
<b>1:25 PM MON 11 MAY 2015</b>

**Note:** If a station is not equipped to receive messages, a reorder tone is heard and the display indicates as follows:

<b>MESSAGE REST</b>
<b>1:25 PM MON 11 MAY 2015</b>

## To ANSWER A MESSAGE

**DT830** **DT430/410**

### To Display

STEP 1: The **MSG** key's LED is lit. The station is an idle state.

STEP 2: Press the **MSG** key.

STEP 3: Press the **MSG** key again to display additional messages in order received.

Calling  
station

<b>MSG 2001</b>	<b>12:28PM</b>
<b>1:25 PM</b>	<b>MON 11 MAY 2015</b>

### To Respond

STEP 1: While displaying the desired message, press  key.

STEP 2: Press the **MSG** key. The station which left message is automatically redialed.

STEP 3: The message is erased.

### To Erase

STEP 1: To erase a message without returning the call, press the **MSG** key to display the desired message.

STEP 2: Dial # or ✕ while the message displays. The message is erased.

<b>MESSAGE CANCEL</b>
<b>1:25 PM MON 11 MAY 2015</b>

**Note:** If the station that left message is busy, callback or the **MSG** may be set. If the station that left message does not answer, the **MSG** may be set, notifying originating party that a message return was attempted.

## VOICE MAIL SYSTEM

**DT830 DT430/410**

### To Set

- STEP 1: Press **Feature** key.
- STEP 2: Press **Enter** or **Message** key.
- STEP 3: Dial the desired “Voice Mail System” access code.
- STEP 4: Press **Feature** key again.

<b>SPEED SET</b> <b>1:25 PM MON 11 MAY 2015</b>
--

### To Originate

- STEP 1: Press **Message** key.
- STEP 2: Hear a ringback tone.
- OR –**
- STEP 2: Press **Enter** key. The Shortcut menu screen is displayed on the LCD.
- STEP 3: Select **2 Voice Mail** and then press **Enter**, **Right-cursor** or the **OK** soft key to access a preset Voice Mail System.
- STEP 4: Hear a ringback tone.

## MEET-ME PAGING

**DT830 DT430/410**

### Example:

Station A can page Station B. When Station B dials answer code, they are connected.

### To Page (Station A)

- STEP 1: Dial “Paging” access code, receive a continuous ringback for one second.
- STEP 2: Page station B.
- STEP 3: Remain off-hook or hang-up.

Trunk number

<b>PAGING</b>	<b>3</b>
<b>1:25 PM MON 11 MAY 2015</b>	

### To Answer (Station B)

#### If Station A remains off-hook

- STEP 1: Station B dials “Paging” answer code, and they are immediately connected.

<b>PAGING</b>	<b>3</b>
<b>1:25 PM MON 11 MAY 2015</b>	

#### If Station A hung up

- STEP 1: Station B dial “Paging” answer code, and Station A rings.

STEP 2: When Station A goes off-hook, they are connected.

**Note:** Paging function can not be supported with IP enabled DT830 Series.

## PAGING TRANSFER

**DT830** **DT430/410**

Example:

Station A receives an important call for Station B who is not at a desk. Station A can page Station B. When Station B dials the Paging answer code, Station A can announce the call and transfer it to Station B.

Calling trunk  
number

<b>TRANSFER</b>	<b>DDD 3</b>
<b>1:25 PM</b>	<b>MON 11 MAY 2015</b>

### Station A Paging

STEP 1: Ask calling party to hold.

STEP 2: Press **Transfer** key. Receive an interrupted dial tone.

STEP 3: Dial “Paging” access code. Receive a continuous ringback for one second.

STEP 4: Page Station B.

STEP 5: Remain off-hook or hang-up.

### To Answer (Station B)

#### If Station A remained off hook

STEP 1: Station B dials “Paging” answer code, and is connected with Station A. Station A announces call.

Stations A and B each display  
the other’s number

<b>TRANSFER</b>	<b>XXXX</b>
<b>1:25 PM</b>	<b>MON 11 MAY 2015</b>

STEP 2: Station A hangs up. Station B and the calling party are connected.

<b>1:25 PM</b>	<b>MON 11 MAY 2015</b>	<b>DDD 3</b>
----------------	------------------------	--------------

### If Station A hung up

STEP 1: Station B dials "Paging" answer code. Station A rings.

Stations A and B each display the other's number, flashing

<b>TRANSFER</b>	<b>DDD 3</b>
<b>1:25 PM</b>	<b>MON 11 MAY 2015</b>

STEP 2: Station A picks up and announces call.

STEP 3: Station A hangs up. Station B and the calling party are connected.

Calling trunk number

	<b>DDD 3</b>
<b>1:25 PM</b>	<b>MON 11 MAY 2015</b>

**- OR -**

(Dependent on System Programming)

STEP 3: Station B dials "Paging" answer code, and is immediately connected to the calling party.

<b>PAGING</b>	<b>DDD 3</b>
<b>1:25 PM</b>	<b>MON 11 MAY 2015</b>

## BOSS/SECRETARY TRANSFER

**DT830** **DT430/410**

### Secretary

STEP 1: Lift the handset, press the boss's ringing line. Ask the calling party to hold.

Calling party

	<b>DDD 3</b>
<b>1:25 PM</b>	<b>MON 11 MAY 2015</b>

STEP 2: Press the boss's line again. "Voice Call" is automatically established.

Boss and secretary station each display the other's number

<b>ICM</b>	<b>XXXX</b>
<b>1:25 PM</b>	<b>MON 11 MAY 2015</b>

STEP 3: Announce the call to the boss.

### If Boss Accepts Call

STEP 1: Secretary replaces the handset.

STEP 2: Secretary presses the boss's line to return to the calling party.

### If Boss Refuses Call

STEP 1: Secretary presses the boss's line to return to the calling party.

## BOSS/SECRETARY - MW LAMP CONTROL **DT830** **DT430/410**

### To Set MW at Boss's Station

#### Pattern1:

STEP 1: Lift the handset or press **Speaker** key.

STEP 2: Press the boss' ringing line. Ask the calling party to hold.

STEP 3: Press the **MSG Wait** line/feature key. No service set tone is heard.

<b>MSG Wait</b> <b>1:25 PM MON 11 MAY 2015</b>
---

Boss sees the **MW** on display and can call secretary to receive message.

#### Pattern2:

STEP 1: After taking message, press **Recall** key and receive dial tone.

STEP 2: Press the **MSG Wait** line/feature key. Receive a service set tone.

<b>MSG Wait</b> <b>1:25 PM MON 11 MAY 2015</b>
---

**Note:** The secretary can hang up after taking a message, and set a message lamp at any time by going off-hook on the boss' multiline and pressing the **MSG Wait** key.

### To Cancel At Boss's Station

#### Pattern1:

STEP 1: Lift the handset or press **Speaker** key. Receive a dial tone.

STEP 2: Press the Boss's line appearance.

STEP 3: Press the **MW-CANCEL** line/feature key. Receive a service set tone.

<b>MW</b> <b>1:25 PM MON 11 MAY 2015</b>	<b>CANCEL</b>
---	---------------

#### Pattern2:

STEP 1: While engaged in conversation on boss' multiline, press the **MW-CANCEL** key. No service set tone is heard.

<b>MW</b> <b>1:25 PM MON 11 MAY 2015</b>	<b>CANCEL</b>
---	---------------

## BOSS SECRETARY OVERRIDE

**DT830** **DT430/410**

Example:

Station 2000 is boss, Station 2001 is secretary.

Boss is connected to Trunk A.

Incoming call on Trunk B connects to secretary, but is intended for boss.

### To Program Boss/Secretary Override Key

STEP 1: Press **Feature** key.

STEP 2: Press the **One-Touch Speed Calling** key.

STEP 3: Dial “Boss/Secretary Override” access code.

STEP 4: Press **Recall** key. – displays on LCD.

STEP 5: Dial the boss’ station number.

STEP 6: Press **Feature** key again.

### Secretary

STEP 1: Lift the handset to answer Trunk B, ask caller to hold.

STEP 2: Press the **CALL HOLD** feature key or **Transfer** key and dial call hold access code. Receive a Dial Tone.

STEP 3: Press the **BOSS/SEC OVERRIDE**. Receive a ringback Tone.

Boss’ station  
number

<b>C WAIT</b>	<b>2000</b>
<b>1:25 PM</b>	<b>MON 11 MAY 2015</b>

### Boss

STEP 1: Hear 3 bursts of tone. LCD indicates:

Secretary’s station  
number

<b>C WAIT</b>	<b>2001</b>
<b>1:25 PM</b>	<b>MON 11 MAY 2015</b>

### Option 1

STEP 1: Boss presses **Answer** key and converses with secretary. Trunk A is placed on hold.

STEP 2: Secretary hangs up. Boss is connected to Trunk B.

STEP 3: Boss can alternate between the two parties by pressing **Answer** key.

### Option 2

STEP 1: Boss presses **Answer** key and converses with secretary. Trunk A is placed on hold.

STEP 2: Boss presses the station 01 key and converses with Trunk B. Boss presses **Answer** key to reconnect to Trunk A.



STEP 3: Secretary hears a reorder tone, hangs up.

STEP 4: Boss can alternate between the two parties by pressing **Answer** key.

### Option 3

STEP 1: If boss does not respond to 3 bursts of tone, secretary presses **Recall** key.

STEP 2: Secretary is connected to Trunk B.

### Option 4

STEP 1: Boss presses **Answer** key and converses with Secretary. Trunk A is placed on hold.

STEP 2: Boss denies call, presses **Transfer** key to return to Trunk A.

STEP 3: Secretary is returned to Trunk B.

## DO NOT DISTURB **DT830** **DT430/410**

### While an Idle State (On Hook)

STEP 1: Press the **NoDist** key. LED lights.

```
NoDist SET
1:25 PM MON 11 MAY 2015
```

**Note:** With soft key operation, "NoDist" flashes when set.

### To Cancel

STEP 1: Press the **NoDist** key. LED goes out.

```
NoDist CANCEL
1:25 PM MON 11 MAY 2015
```

### Using Soft Key

STEP 1: Press the flashing **NoDist** soft key.

```
NoDist CANCEL

Mic NoDist >>>
```

**Note:** **NoDist** must be programmed by the Telephony Server administrator on a Programmable feature key.

## CALL REDIRECT **DT830** **DT430/410**

Example:

Station A views on the terminal display the Station Number or Caller ID of an Incoming Call and immediately redirects the call by pressing a Function Key. The destination of the Call Redirect will be the Call Forwarding-Don't Answer Destination or the Recall Destination if the call is transferred without Call Forwarding-Don't Answer being set at the station.

**Note:** This feature is available in North America only.

### **Call Redirect To Call Forward-Don't Answer Destination**

- STEP 1: Station A sets Call Forward-Don't Answer to Station B.
- STEP 2: Station C dials Station A, it rings and displays Station C's number on the display.
- STEP 3: Station A presses the Call Redirect Key.
- STEP 4: REDIRECT is displayed on the LCD, and the call immediately forwards to Station B.

### **Using Soft Key**

- STEP 1: Station A sets Call Forward-Don't Answer to Station B.
- STEP 2: Station C dials Station A, it rings and displays Station C's number on the display.
- STEP 3: Station A presses the **REDIR** soft key.
- STEP 4: REDIRECT is displayed on the LCD, and the call immediately forwards to Station B.

- OR -

### **Call Redirect to Recall Destination When Call Is Transferred Without Call Forwarding-Don't Answer Being Set**

- STEP 1: Station B calls Station C.
- STEP 2: Station C answers the call and transfers it to Station A and then releases the call.
- STEP 3: Station A rings.
- STEP 4: Station A presses the Call Redirect Key.
- STEP 5: REDIRECTING is displayed on Station A and the call immediately recalls to Station C.

## Using Soft Key

- STEP 1: Station B calls Station C.
- STEP 2: Station C answers the call and transfers it to Station A and then releases the call.
- STEP 3: Station A rings.
- STEP 4: Station A presses the **REDIR** soft key.
- STEP 5: REDIRECTING is displayed on Station A and the call immediately recalls to Station C.

## PRIVACY **DT830** **DT430/410**

### While Off-Hook

- STEP 1: Press the **NoDist** key. LED lights.
- STEP 2: Privacy feature prevents interruptions for the duration of the call.

**PRIVACY SET**  
**1:25 PM MON 11 MAY 2015**

### Using Soft Key

- STEP 1: Press the flashing **NoDist** soft key. “NoDist” flashes when set.
- STEP 2: Privacy feature prevents interruptions for the duration of the call.

**PRIVACY SET**  
**1:25 PM MON 11 MAY 2015**  
**Mic >>>**

## To Cancel

STEP 1: Press the **NoDist** key. LED goes out.

<b>PRIVACY CANCEL</b> <b>1:25 PM MON 11 MAY 2015</b>
---

– OR –

STEP 1: Replace the handset. Privacy feature is automatically cancelled.

**Note:** The **NoDist** key must be programmed by the Telephony Server administrator on a Programmable feature key.

## Using Soft Key

STEP 1: Press the flashing **NoDist** soft key.

<b>PRIVACY CANCEL</b> <b>1:25 PM MON 11 MAY 2015</b> <b>Mic NoDist &gt;&gt;&gt;</b>
---

## PRIVACY RELEASE

**DT830 DT430/410**

Example:

Station B is engaged in a conversation, and allows Station A to enter the call in progress.

STEP 1: Station A lifts handset or presses **Speaker** key. Station A presses the line appearance of Station B.

Warning tone is sent to the interrupted parties (optional).

A three-way conference is established.

<b>CONF</b> <b>1:25 PM MON 11 MAY 2015</b>
---

**Note:** Station A may also be a single-line station as long as it appears on the Station B.

– OR –

Example:

Station A requests entrance into Station B's call in progress.

STEP 1: Station A lifts the handset or presses **Speaker** key.

STEP 2: Station A presses the line appearance of Station B.

**WAIT Priv.Rel?**  
**1:25 PM MON 11 MAY 2015**

STEP 3: Station B LCD indicates as follows:

**Priv.Rel?**  
**1:25 PM MON 11 MAY 2015**

STEP 4: Station B may allow Station A to enter the conversation by pressing **Priv.Rel**.

STEP 5: Warning tone is sent to the interrupted parties (optional).

STEP 6: A three-way conference is established.

**CONF**  
**1:25 PM MON 11 MAY 2015**

**Note:** Station A can be a single-line station if it appears on the Station B.

**Note:** Up to six parties can break into a two-party conversation (additional device is required).

## PHONEBOOK **DT830** **DT430/410**

There are two types of Phonebook features: Local Phonebook and System Phonebook.

**Note:** This feature is available for the terminal with LCD.

**Note:** When the system administrator invalidates the Phonebook, this feature cannot be used. For details contact the system administrator.

### System Phonebook

System Phonebook is used on a system basis. Up to 12000/60000 entries are available per system. The data entry is made by the Telephony Server administrator.

Up to 32 digits can be registered for each dial number. Up to 24 characters can be registered for each name.

**Note:** To make the maximum number of Phonebook entries as 60000, SV9500 V2 or later is required. For details, please contact the system administrator.

### Local Phonebook

Local Phonebook is used on a station basis. Up to 100 entries are available per station. You can make entries with key operation from the telephone.

Up to 32 digits can be registered for each dial number. Up to 24 characters can be registered for each name.

## • SYSTEM PHONEBOOK

### To Search And Make a Call

Example: To Search For “NEC BNET”.

STEP 1: Press the **P.Book** soft key while the Station is in an idle state.



If Local Phonebook is enabled by the setting on the system side, go to STEP 2.

If Local Phonebook is disabled by the setting on the system side, go to STEP 3.

- OR -

Press  key to display the Menu screen. On the Menu screen, select **2 Directory**.

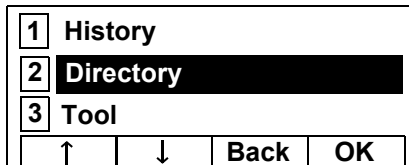

**Note:** Select an item on the menu screen in either of the following two ways.

- Press an appropriate digit key.
- Highlight a desired item and then press  or the **OK** soft key.

If Local Phonebook is enabled by the setting on the system side, go to STEP 2.

If Local Phonebook is disabled, the display changes as follows. In that case, select **2 System** and go to STEP 3.

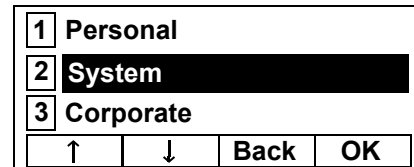

STEP 2: Press the **Sys** soft key.

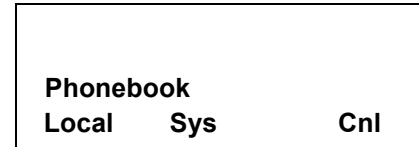

STEP 3: Enter a name and then press  or the **OK** soft key to perform a search.

Ex. To enter “NEC”:

Press **6** key twice to enter “N”.

Press **3** key four times to enter “E”.

Press **2** key twice to enter “C”.

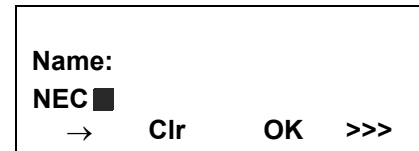

**Note:** If “>>>” soft key is pressed on the above screen, the following soft keys appear. Pressing  or the **Eu-s/Eu-l** soft key shifts characters between the uppercase and lowercase.

(Lower-case character)

<<< **-Eu-s** Cnl

(Upper-case character)

<<< **-Eu-l** Cnl

**Note:** To delete an entered character, press  or the **Clr** soft key.

**Note:** To move the cursor one space to the right, press  key or the **RIGHT** soft key once

STEP 4: A result of the search is displayed. Press  or the **UP/DOWN** soft key to scroll the result.

**Search: NEC**  
**Name: NEC ABIKO**  
**Number: XXXXXXX1**  
**UP DOWN More >>>**

STEP 5: The registered Phonebook data for “NEC BNET” appears. From this screen, you can make a call by going off-hook or pressing  key.

**Search: NEC**  
**Name: NEC BNET**  
**Number: XXXXXXXX**  
**UP DOWN More >>>**

**Note:** The **More** soft key appears in Phonebook data screen when the number of characters (name) or digits (telephone number) are exceeding displayable limit (Up to 17 characters or digits can be displayed at a time). If the name or telephone number exceeds the displayable limit, press  or the **More** soft key to display the last 17 characters/digits of the name/telephone number.

Example:

Name Suzuki Taro(JapanSumida) : 24 characters

Number: 01234567890123456789 : 20 digits

**Name : Suzuki Taro(Japan**  
**Number : 01234567890123456**  
**More Cnl >>>**

(Display area)

Name: Suzuki Taro(JapanSumida)

Number: 01234567890123456789

**Name : Taro(JapanSumida)**  
**Number : 34567890123456789**  
**More Cnl >>>**

(Display area)

Name: Suzuki Taro(JapanSumida)

Number: 01234567890123456789

## • LOCAL PHONEBOOK

### To Add New Data

Example:

Station A registers “NEC” as new name and its Telephone Number.

STEP 1: Press the **P.Book** soft key or  (Directory) key while the Station is in an idle state.

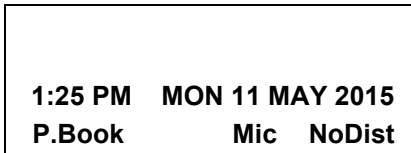

- OR -

Press  key to display the Menu screen.  
On the Menu screen, select **2** **Directory**.

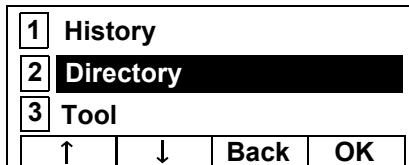

**Note:** Select an item on the menu screen in either of the following two ways.

- Press an appropriate digit key.
- Highlight a desired item and then press  or the **OK** soft key.

STEP 2: Press the **Local** soft key.

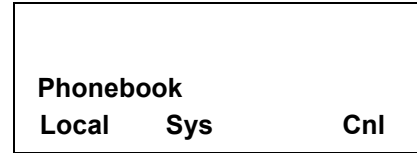

STEP 3: Local Phonebook screen appears. Press the **Add** soft key.

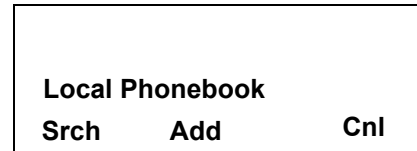

STEP 4: Enter a name and then press  or the **OK** soft key.

Ex. To enter “NEC”:

Press **6** key twice to enter “N”.

Press **3** key twice to enter “E”.

Press **2** key three times to enter “C”.

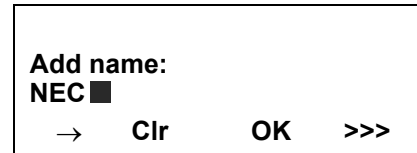

**Note:** If “>>>” soft key is pressed on the above screen, the following soft keys appear. Pressing  or the **Eu-s/Eu-l** soft key shifts characters between the uppercase and lowercase.





(Lower-case character)

<<< -Eu-s Cnl

(Upper-case character)

<<< -Eu-l Cnl

**Note:** To delete an entered character, press  or the **Clr** soft key.

**Note:** To move the cursor one space to the right, press  key or the **RIGHT** soft key once.

STEP 5: Enter the telephone number by using digit keys and press  or the **OK** soft key.

Name: NEC  
Number: ■  
Clr OK Cnl

**Note:** To delete an entered digit, press  or the **Clr** soft key.

STEP 6: “NEC” and its telephone number has been added into Local Phonebook. Two seconds later, the display returns to Local Phonebook screen.

Entry added!

## To Search For Name

The procedure shown below is available in Local Phonebook.

Example: To Find “NEC BNET”.

STEP 1: While Local Phonebook screen is displayed, press the **Srch** soft key. (If no data is registered in Local Phonebook, the message “Local phone book empty” appears.)

Local Phonebook  
Srch Add Cnl

STEP 2: Name Entry screen appears.

Name:  
■  
→ Clr OK >>>

STEP 3: Enter a name (in this example, “NEC” is entered) and then press  or the **OK** soft key. (If no appropriate data exists, the message “Entry not found!” appears.)

Name:  
NEC ■  
→ Clr OK >>>

**Note:** If “>>>” soft key is pressed on the above screen, the following soft keys appear. Pressing  or the **Eu-s/Eu-l** soft key shifts characters between the uppercase and lowercase.

(Lower-case character)

<<< **-Eu-s** **Cnl**

(Upper-case character)

<<< **-Eu-l** **Cnl**

**Note:** To delete an entered character, press  or the **Clr** soft key.

**Note:** To move the cursor one space to the right, press  key or the **RIGHT** soft key once.

STEP 4: A result of the search is displayed. Press  or the **UP/DOWN** soft key to scroll the result.

**Search: NEC**  
**Name: NEC ABIKO**  
**Number: XXXXXXXX1**  
**UP DOWN More >>>**

STEP 5: The registered data for “NEC BNET” appears. From this screen, you can make a call by going off-hook or pressing  key.

**Search: NEC**  
**Name: NEC BNET**  
**Number: XXXXXXXX**  
**UP DOWN More >>>**

**Note:** The **More** soft key appears in Phonebook data screen when the number of characters (name) or digits (telephone number) are exceeding displayable limit (Up to 17 characters or digits can be displayed at a time). If the name or telephone number exceeds the displayable limit, press  or the **More** soft key to display the last 17 characters/digits of the name/telephone number.

## To Edit An Entry

Example:

To Modify Name "Home" to "House" and Telephone Number "0123456789" to "0123456712".

STEP 1: Press ">>>" soft key twice while the target Phonebook data is displayed.

<b>Search: Home</b> <b>Name: Home</b> <b>Number: 0123456789</b> <b>UP DOWN More &gt;&gt;&gt;</b>
---

STEP 2: Press the **Edit** soft key.

<b>Search: Home</b> <b>Name: Home</b> <b>Number: 0123456789</b> <b>&lt;&lt;&lt; Edit Delete</b>
--

STEP 3: The following name edit screen appears.

<b>Edit Name:</b> <b>Home</b> ■ → <b>Clr</b> <b>OK</b> <b>&gt;&gt;&gt;</b>
--

STEP 4: Press  or the **Clr** soft key two times to erase "me".

<b>Edit Name:</b> <b>Ho</b> ■ → <b>Clr</b> <b>OK</b> <b>&gt;&gt;&gt;</b>
--

STEP 5: Enter "use" by using digit keys. After the modification has completed, press  or the **OK** soft key.

Press **8** key twice to enter "u".

Press **7** key four times to enter "s".

Press **3** key twice to enter "e".

<b>Edit Name:</b> <b>House</b> ■ → <b>Clr</b> <b>OK</b> <b>&gt;&gt;&gt;</b>
---

**Note:** If ">>>" soft key is pressed on the above screen, the following soft keys appear. Pressing  or the **Eu-s/Eu-l** soft key shifts characters between the uppercase and lowercase.

(Lower-case character)

<b>&lt;&lt;&lt; -Eu-s Cnl</b>
-------------------------------

(Upper-case character)

<b>&lt;&lt;&lt; -Eu-l Cnl</b>
-------------------------------

**Note:** To delete an entered character, press  or the **Clr** soft key.

**Note:** To move the cursor one space to the right, press  key or the **RIGHT** soft key once.

STEP 6: The following number edit screen appears.

<b>Name: House</b> <b>Number: 0123456789</b> ■ <b>Clr</b> <b>OK</b> <b>Cnl</b>
--

STEP 7: Press  or the **Clr** soft key twice to erase “89”.

**Name: House**  
**Number: 01234567**■  
**Clr OK Cnl**

STEP 8: Enter “12” by pressing digit keys and then press  or the **OK** soft key.

**Name: House**  
**Number: 0123456712**  
**Clr OK Cnl**

STEP 9: The data modification has completed. Two seconds later, the display returns to Local Phonebook screen.

**Entry edited!**

## To Delete A Record

STEP 1: Press “>>>” soft key twice while the target Phonebook data is displayed.

**Search: NEC ABIKO**  
**Name: NEC ABIKO**  
**Number: 0123456789**  
**UP DOWN More >>>**

STEP 2: Press the **DEL** soft key.

**Search: NEC ABIKO**  
**Name: NEC ABIKO**  
**Number: 0123456789**  
**<<< EDIT DEL**

STEP 3: Press  or the **OK** soft key to delete the currently displaying data.

**Delete this entry?**  
**Name: NEC ABIKO**  
**Number: 0123456789**  
**OK Cnl**

STEP 4: The data deletion has completed. Two seconds later, the display returns to Name Entry screen.

**Entry deleted!**

## To Add A Prefix To Telephone Number

The procedure shown below is available in Local Phonebook.

Example:

To add a prefix “0184” in front of telephone number “0123456789”

STEP 1: Press “>>>” soft key while the target Phonebook data is displayed.

<b>Search: Takahashi</b> <b>Name: Takahashi</b> <b>Number: 0123456789</b> <b>UP DOWN More &gt;&gt;&gt;</b>
---

STEP 2: Press the **Pref** soft key.

<b>Search: Takahashi</b> <b>Name: Takahashi</b> <b>Number: 0123456789</b> <b>&lt;&lt;&lt; Pref Cnl &gt;&gt;&gt;</b>
--

STEP 3: Enter a prefix (In this example, “0184” is entered) by using digit keys and press  or the **OK** soft key.

<b>Prefix Number Input</b> <b>Number: 0184■</b> <b>Clr OK Cnl</b>
---

**Note:** To delete an entered digit, press  or the **Clr** soft key.

STEP 4: The prefix is added in front of the telephone number. Once the prefix is added, the **Pref** soft key will disappear.

<b>Search: Takahashi</b> <b>Name: Takahashi</b> <b>Number: 01840123456789</b> <b>&lt;&lt;&lt; Cnl &gt;&gt;&gt;</b>
---

**Note:** The **More** soft key appears in Phonebook data screen when the number of characters (name) or digits (telephone number) are exceeding displayable limit (Up to 17 characters or digits can be displayed at a time). If the name or telephone number exceeds the displayable limit, press  or the **More** soft key to display the last 17 characters/digits of the name/telephone number.

## Available Characters In Local Phonebook

The following tables show available characters in Local Phonebook.

### UPPERCASE CHARACTER

Digit Code	1	2	3	4	5	6	7	8	9	0	*	#
Character	.	A	D	G	J	M	P	T	W	SP	*	#
	,	B	E	H	K	N	Q	U	X	0		
	:	C	F	I	L	O	R	V	Y			
	!	À	É	Ì	5	Ñ	S	Ú	Z			
	?	Á	Ê	Í		Ò	b	Ú	9			
	-	Â	Ë	Î		Ó	7	Û				
	+	Ã	Ë	Ï		Ö		Ü				
	%	Ä	3	4		Ö		8				
	&	Å				Ö						
	/	Æ				Œ						
	(	Ç				Ø						
	)	2				6						
	=											
	¿											
	¡											
1												

SP: Blank Space

### LOWERCASE CHARACTER

Digit Code	1	2	3	4	5	6	7	8	9	0	*	#
Character	.	a	d	g	j	m	p	t	w	SP	*	#
	,	b	e	h	k	n	q	u	x	0		
	:	c	f	i	l	o	r	v	y			
	!	à	è	ì	5	ñ	s	ù	z			
	?	á	é	í		ò	b	ú	9			
	:	â	ê	î		ó	7	û				
	\	ä	ë	ï		ô		ü				
	"	å	3	4		ö		8				
	@	æ				ö						
	1	ç				6						
	2											

SP: Blank Space

## CALL HISTORY **DT830** **DT430/410**

There are two types of Call History features. On the one hand, the history data is stored in the system memory. On the other hand, the history data is stored in the memory of the telephone (see [7.CALL HISTORY OPERATION](#)).

The following describes the operating procedures for the Call History feature which controlled by the system. This Call History feature can store up to 20 records. If exceeding 20 records, a record will be deleted in order of occurrence. Also, this Call History feature can store up to 32 digits of dial number and 16 characters of name information per record.

**Note:** When the system administrator invalidates the Phonebook, this feature cannot be used. For details contact the system administrator.

### To View Call History

STEP 1: Press **History** soft key or **Call History** Feature key while the current time is displayed on LCD.



5:25 PM MON 11 MAY 2015  
History Mic NoDist

- OR -

STEP 1: Press **Menu** key to display the Menu screen. On the Menu screen, select **1 History** (for DT830 Series)/**1 Call History** (for DT430 Series) and then press **OK** or the **OK** soft key. (or press **1** key.)

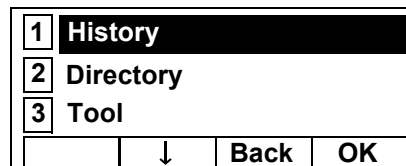

1 History  
2 Directory  
3 Tool  
↓ Back OK

STEP 2: The history data of the last received call is displayed.

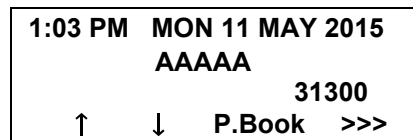

1:03 PM MON 11 MAY 2015  
AAAAA 31300  
↑ ↓ P.Book >>>

**Note:** If no history data is saved, "NO LIST" will be displayed on LCD.

STEP 3: Press  or the **UP/DOWN** soft key to display a desired history data.

```
12:55 PM MON 11 MAY 2015
!!          BBBBB
                51500
    ↑      ↓   P.Book  >>>
```



**Note:** Call History will display “!!” for an unanswered incoming call.

**Note:** If the calling party information is not notified, Call History will display “----” to the history data.

## To Make A Call From Call History

STEP 1: Display the history data of the target party.

```
1:03 PM MON 11 MAY 2015
!!          BBBBB
                51500
    ↑      ↓   P.Book  >>>
```

STEP 2: Go off-hook or press  key, , or the **OK** soft key to make a call to the displayed party.

**Note:** While the history data is displayed, you cannot make a call by dialing a telephone number.

## To Make A Call With Prefix

STEP 1: Press “>>>” soft key while the history data to which you want to add a prefix.

```
1:03 PM MON 11 MAY 2015
AAAAA
                31300
    ↑      ↓   P.Book  >>>
```

STEP 2: Press the **Pref** soft key.

```
1:03 PM MON 11 MAY 2015
AAAAA
                31300
<<< Pref Delete End
```

STEP 3: Enter a prefix by using the digit keys. In this example, “012345” is entered. After entering the prefix, press  or the **OK** soft key.

```
Prefix Number Input
Number:█
        Clr   OK   Cnl
```

**Note:** A maximum of 10 digits (0-9, \* and #) can be set as a prefix.

**Note:** When prefix is added, up to 32 digits including the prefix can be sent as dial number.

**Note:** To delete an entered character, press  or the **Clr** soft key.



STEP 4: If the call history data has name information, the name is displayed as follows:

<b>Name</b> :AAAAA <b>Number</b> :01234531300 ■ Cnl
---

**Note:** The **More** soft key appears in Phonebook data screen when the number of characters (name) or digits (telephone number) are exceeding displayable limit (Up to 17 characters or digits can be displayed at a time). If the name or telephone number exceeds the displayable limit, press  or the **More** soft key to display the last 17 characters/digits of the name/telephone number.

STEP 5: Go off-hook or press  key to make a call to the displayed telephone number.

## To Delete A Specific Data

STEP 1: Press “>>>” soft key while the history data which you want to delete is displayed.

1:03 PM	MON 11 MAY	2015
AAAAA		
		31300
↑	↓	P.Book >>>

STEP 2: Press the **Delete** soft key.

1:03 PM	MON 11 MAY	2015
AAAAA		
		31300
<<<	Pref	Delete End

**Note:** If you want to exit Call History, press the **End** soft key.

## To Add Call History Data To Local Phonebook

**Note:** The Call History data stored on the system can be added to Phonebook (controlled by the system) only. The data cannot be added to the Personal Directory (described in [6.DIRECTORY OPERATION](#)) controlled by the telephone.

STEP 1: Press the **P.Book** soft key or the **Phonebook** Feature key while the history data of the target party.

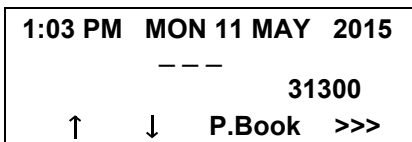

1:03 PM MON 11 MAY 2015  
---  
31300  
↑ ↓ P.Book >>>

**Note:** Local Phonebook feature allows you to register up to 100 records. If exceeding 100 records at this point, the error message shown below appears. Press the **OK** soft key to go back to the above display.

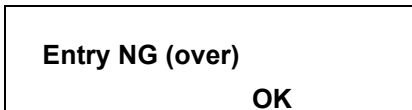

Entry NG (over)  
OK

STEP 2: Enter a desired name and then press the **OK** soft key.  
(In this example, "NEC ABIKO" is entered.)

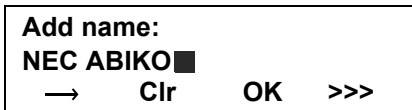

Add name:  
NEC ABIKO ■  
→ Clr OK >>>

**Note:** If name information is stored on the call history, the name is displayed.

**Note:** If ">>>" soft key is pressed on the above screen, the following soft keys appear. Pressing  or the **Eu-s/Eu-l** soft key shifts characters between uppercase and lowercase.

(Lower-case character)



<<< -Eu-s Cnl

(Upper-case character)



<<< -Eu-l Cnl

# 6. DIRECTORY OPERATION

This chapter explains about Personal Directory function of DT830 Series. By using Personal Directory function, you can make a call with simple operation.

Personal Directory function can register up to 500 entries (4 telephone numbers per entry). You can add/view/edit/delete these entries. If the directory contains 500 entries (maximum), entries can be removed using

- TO ADD NEW DATA
- TO CHANGE GROUP NAME
- TO FIND REGISTERED DATA
- TO MAKE A CALL FROM DIRECTORY
- TO ADD PREFIX TO NUMBER
- TO EDIT DIRECTORY DATA
- TO DELETE ALL DATA
- TO DELETE SPECIFIC DATA

## TO ADD NEW DATA **DT830**

**Note:** A maximum of 500 entries can be registered in Directory.

STEP 1: While indicating the current time on LCD, press **Menu** key to open the **Menu** screen.

-OR-

Press **Directory** key. The **Directory** screen shown at STEP 3 can be directly displayed.

**Note:** Directory feature is available for DT830 Series only. DT430/DT410 Series does not support the directory feature.

STEP 2: Select **1 Personal**.

Select an item by either of the following operations.

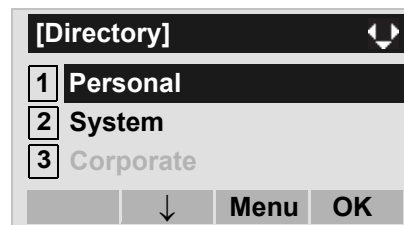

- Highlight an item by using **UP/DOWN** soft key, and then press **Left**, **Right** or **OK** soft key.
- Press **1** key.



**Note:** When using Phonebook feature is disabled, this screen will not be displayed. In that case, skip this step.

STEP 3: Select **2** Edit.

Select an item by either of the following operations.

- Highlight an item by using  or **UP/DOWN** soft key, and then press ,  or **OK** soft key.
- Press **2** key.



**Note:** If the Personal/Terminal directory contains 500 entries, the following screen appears.

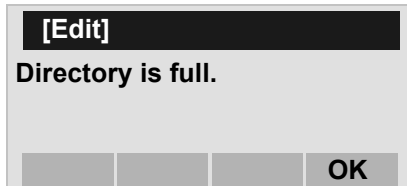

To go back to the Directory screen, press  or **OK**, and delete some entries from **1** Search.

STEP 4: Select **1** Name.

Select an item by either of the following operations.

- Highlight an item by using , and then press ,  or **OK** soft key.
- Press **1** key.

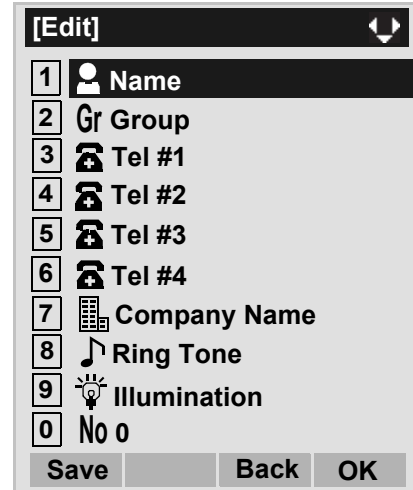

STEP 5: Enter a name to be registered in directory.

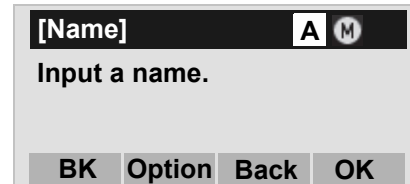

Enter a name by using digits keys. After entering the name, press  or **OK** soft key.



**Note:** Up to 32 characters can be entered as a name. For details on character entry method, see [HOW TO INPUT CHARACTERS](#) in chapter 4.

STEP 6: The display goes back to the **Edit** screen. Select **2** **Group**.

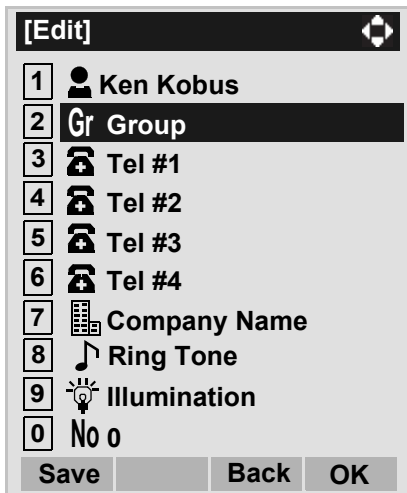

Select an item by either of the following operations.

- Highlight an item by using , and then press ,  or **OK** soft key.
- Press **2** key.



STEP 7: Select a desired group.

Select an item by either of the following operations.

- Highlight an item by using  or **UP/DOWN** soft key, and then press  or **OK** soft key.
- Press **0** - **9** key, and then press  or **OK** soft key.

In this example, **2** **Colleagues** is selected.

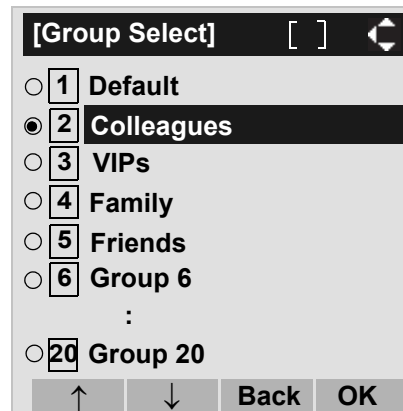

**Note:** Each group name can be changed from the Group Setting screen. For details, see [TO CHANGE GROUP NAME](#).

STEP 8: Select **3** **Tel #1**.

Select an item by either of the following operations.

- Highlight an item by using , and then press ,  or **OK** soft key.
- Press **3** key.

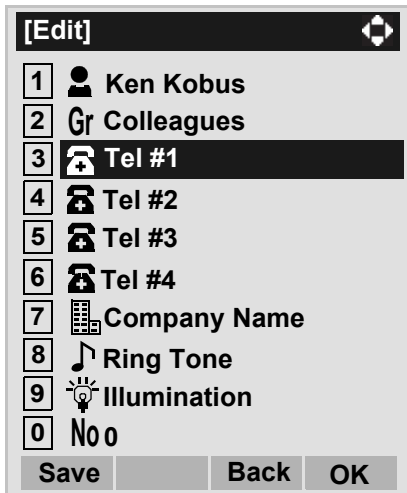

STEP 9: Enter a telephone number to be registered in directory.

Enter a telephone number by using digits keys. After entering the telephone number, press or **Next** soft key.

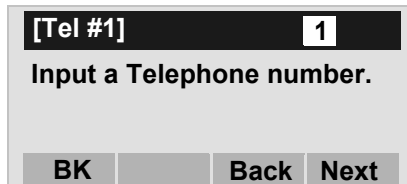

STEP 10: Select a Category to which the entered telephone number belongs.

Select an item by either of the following operations.  
 • Highlight an item by using or **UP/DOWN** soft key,

and then press or **Next** soft key.  
 • Press **0** - **5** key, and then press or **Next** soft key.  
 In this example, **1** **Company** is selected.

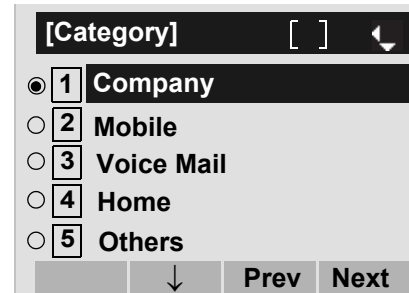

Selectable categories are as follows:

Category	ICON
Company	
Mobile	
Voice Mail	
Home	
Others	<b>etc</b>

**STEP 11:** Select either **1 Disable** or **2 Enable**.

Select an item by one of the following operations.

- Highlight an item by using or **UP/DOWN** soft key, and then press or **OK** soft key.
- Press **1** or **2** key, and then press or **OK** soft key.

A maximum of four telephone numbers can be set to an entry. If **2 Enable** is selected here, the telephone number which is being edited will be given top priority. In that case, the telephone number is automatically selected when you make a call without specifying a specific telephone number.

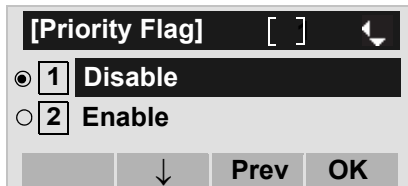

**STEP 12:** The display goes back to the **Edit** screen again. Select **7 Company Name**.

Select an item by either of the following operations.

- Highlight an item by using , and then press , or **OK** soft key.
- Press **7** key.

**Note:** A maximum of four telephone numbers can be set to an entry. If two or more telephone numbers are required to be set, set the remaining telephone numbers to Tel #2 - Tel #4.

**Note:** If multiple telephone numbers are registered to an entry and Priority Flag is disabled to all of the telephone numbers, the telephone number set to Tel #1 is automatically set as first priority number.

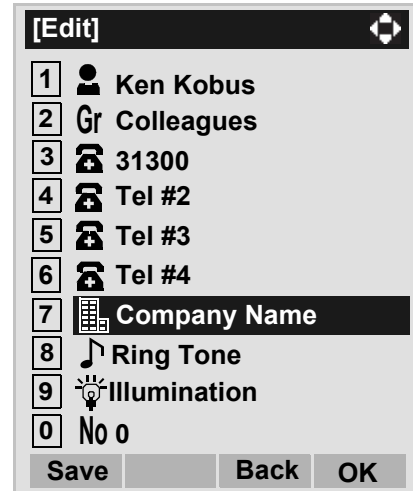

**STEP 13:** Enter a company name.

Enter a company name by using digits keys. After entering the company name, press or **OK** soft key.





**Note:** Up to 32 characters can be entered as a company name. For details on character entry method, see [HOW TO INPUT CHARACTERS](#).

STEP 14: The display goes back to the **Edit** screen. Select

**8** Ring Tone.

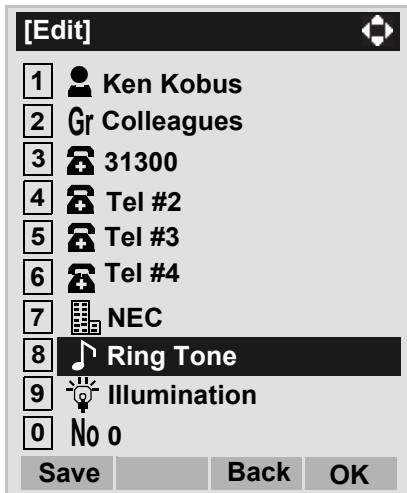

Select an item by either of the following operations.

- Highlight an item by using , and then press ,  or **OK** soft key.
- Press **8** key.



STEP 15: Select a desired Ringing Tone.

Select an item by either of the following operations.

- Highlight an item by using  or **UP/DOWN** soft key, and then press  or **OK** soft key.
- Press **0** - **9** key, and then press  or **OK** soft key.

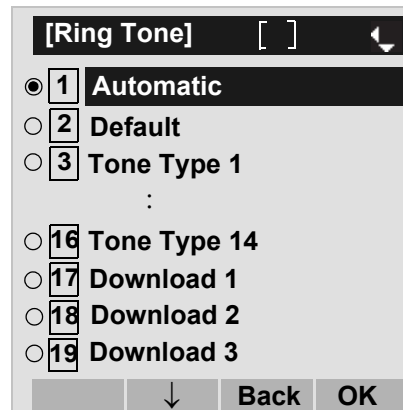

**Note:** You can set ringer tone for calls routed to the specified name (calling party) here. Ringer Tone type can be set for “Name”, “Group” and “Telephone set”. The ringer Tone type set for “Name” has higher priority than the types set for “Group” and “Terminal set”.

**Note:** Set **2 Default** when you don’t want to change the ringer tone here. The setting for “Group” or “Telephone set” is applied. Also, when **1 Automatic** is set, **3 Tone Type 1** is automatically applied.



**Note:** For details on each ringer tone type, see [TO SET RINGER TONE](#).



STEP 16: The display goes back to the **Edit** screen. Select

9 **Illumination**.

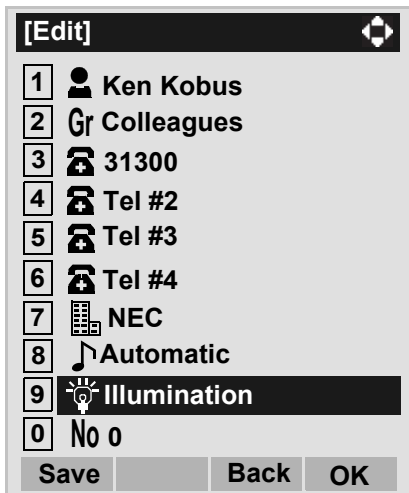

Select an item by either of the following operations.

- Highlight an item by using  or **UP/DOWN** soft key, , or **OK** soft key.
- Press **9** key.



STEP 17: Select a desired color of the Call Indication lamp.

Select an item by either of the following operations.

- Highlight an item by using  or **UP/DOWN** soft key, and then press  or **OK** soft key.
- Press **0** - **9** key.

- For DT830 Series

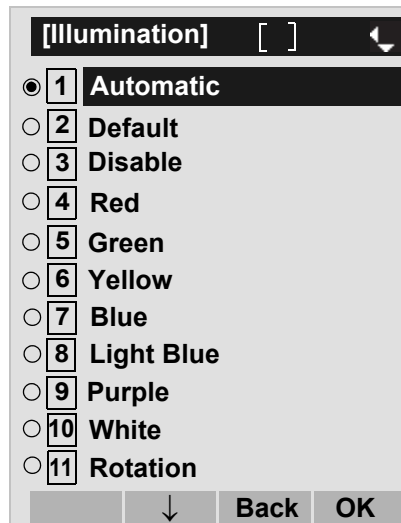

**Note:** You can set illumination type for calls routed to the specified name (calling party) here. Illumination type can be set for “Name”, “Group” and “Telephone set”. The illumination type set for “Name” has higher priority than the types set for “Group” and “Terminal set”.

**Note:** Set **2 Default** when you don't want to change the illumination type here. The setting for “Group” or “Telephone set” is applied. Also, when **1 Automatic** is set, **4 Red** is automatically applied.

STEP 18: The display goes back to the **Edit** screen.  
Check the memory number assigned to the directory data being edited.

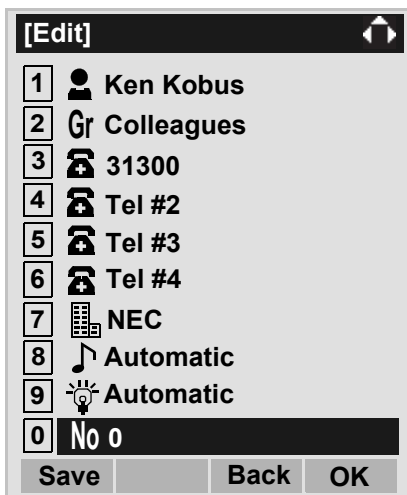

**Note:** A memory number is automatically set in ascending numeric order.

STEP 19: If you need to assign a memory number manually, select **0 Memory ID** on the screen of the previous step, and then enter a desired memory number (0 - 499).

Enter a memory number by using digits keys. After entering the memory number, press  or **OK** soft key.

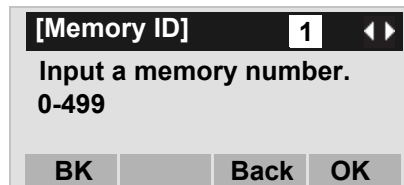

STEP 20: When the display goes back to the **Edit** screen, press **Save** soft key to save the assigned data.

STEP 21: "The data is registered at memory number: XX" is displayed. Press  key or **OK** soft key. The display returns to the **Directory** screen.

**Note:** If Name is not entered, "No Input Name" will appear. Name information is required for an entry.



**Note:** If a duplicate Memory ID is entered, "It will overwrite a data at memory number:XX" will appear. If you do not overwrite the Memory ID, press **Back** soft key. If you overwrite the Memory ID, press  or **OK** soft key.

## TO CHANGE GROUP NAME DT830

STEP 1: Open the **Directory** screen (see [TO ADD NEW DATA](#)).

STEP 2: On the **Directory** screen, select **3 Group Setting**.

Select an item by either of the following operations.



- Highlight an item by using  or **UP/DOWN** soft key, and then press ,  or **OK** soft key.
- Press **3** key.



STEP 3: Select a group name to be changed.

In this example, **1 Default** is selected.

Select an item by either of the following operations.

- Highlight an item by using  or **UP/DOWN** soft key, and then press  or **OK** soft key.
- Press **1** key, and then press  or **OK** soft key.

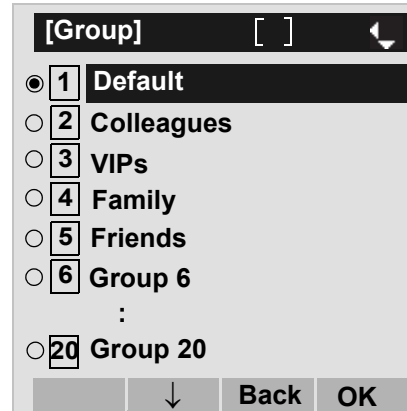

STEP 4: Select **1 Name**.

Select an item by either of the following operations.

- Highlight an item by using  or **UP/DOWN** soft key, and then press ,  or **OK** soft key.
- Press **1** key.



STEP 5: Enter a new group name.

Enter a group name by using digits keys. After entering the group name, press  or **OK** soft key.

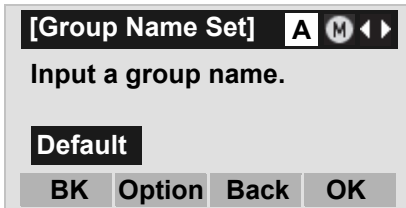

**Note:** Up to 32 characters can be entered as a group name. For details on character entry method, see [HOW TO INPUT CHARACTERS](#) in chapter 4.

STEP 6: Display returns to the **Group** screen. Make sure that the new group name takes effect.

**Note:** You can set ringer tone (→ select 2 Ring Tone) and illumination types (→ select 3 Illumination) for calls routed to the specified group here. Ringer tone and illumination types can be set for “Name”, “Group” and “Telephone set”. The ringer tone and illumination types set for “Name” have higher priority than the types set for Group and Telephone set. Also, the ringer tone and illumination types for Group have higher priority than the types set for Terminal set.

## TO FIND REGISTERED DATA

### DT830

- **To Search by Group Name**

STEP 1: Open the **Directory** screen (see [TO ADD NEW DATA](#)).

STEP 2: Select **1 Search** on the Directory screen.

Select an item by either of the following operations.

- Highlight an item by using or **UP/DOWN** soft key, and then press or **OK** soft key.
- Press **1** key.



STEP 3: Select **1 Group**.

Select an item by either of the following operations.

- Highlight an item by using or **UP/DOWN** soft key, and then press or **OK** soft key.
- Press **1** key.

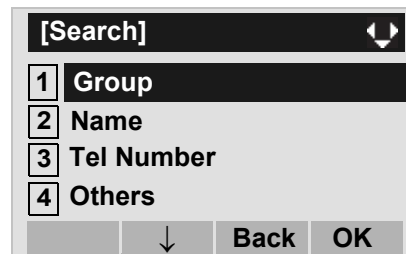

STEP 4: Select a target group.

In this example, **2 Colleagues** is selected.

Select an item by either of the following operations.

- Highlight an item by using or **UP/DOWN** soft key, and then press or **OK** soft key.
- Press **2** key, and then press or **OK** soft key.

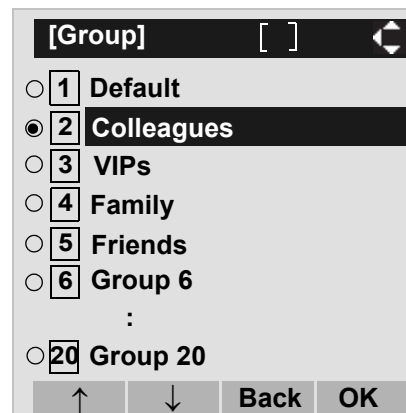

STEP 5: Select a target name by pressing .

In the following **Directory (Name List)** screen, you can make a call to the selected party by pressing  or **Call** soft key. If two or more telephone numbers are assigned to an entry, a top priority telephone number will be dialed.

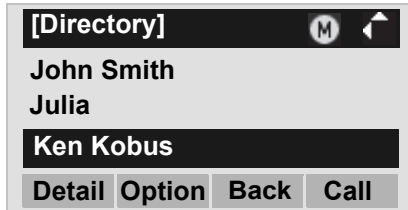

**Note:** If no entry is set to the selected group, "No data" is issued.

STEP 6: To display the detailed data for a specific name, press **Detail** soft key while the name is highlighted.

**Note:** If two or more telephone numbers are assigned to an entry, a top priority telephone number is automatically selected when the Detail screen appears.

In the following **Detail** screen, you can make a call to the selected number by pressing  or **Call** soft key.

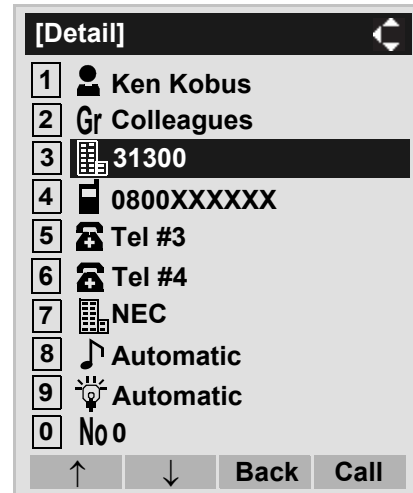



- **To Search by Name**

STEP 1: Open the **Directory** screen (see [TO ADD NEW DATA](#)).

STEP 2: Select **1 Search**.

Select an item by either of the following operations.

- Highlight an item by using  or **UP/DOWN** soft key, and then press  or **OK** soft key.
- Press **1** key.



STEP 3: Select **2 Name**.

Select an item by either of the following operations.

- Highlight an item by using  or **UP/DOWN** soft key, and then press  or **OK** soft key.
- Press **2** key.

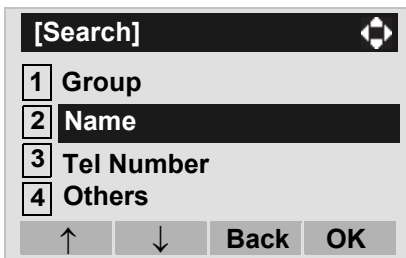

STEP 4: Enter a target name.

After entering the name, Press  or **OK** soft key.



**Note:** A distinction is made between upper case and lower case characters, according as the system settings. For example, "Ken Kobus" and "ken kobus" are distinguished as different character strings. For details, contact the System administrator.

**Note:** A blank space is also distinguished while searching database for a name.

**Note:** Even if the name is not entered to the end, you can search for a name.

**Note:** If there is no entry corresponding to the entered name, "No data" is issued.

**Note:** Up to 32 characters can be entered as a company name. For details on character entry method, see [HOW TO INPUT CHARACTERS](#).

STEP 5: Select a target name by pressing  (Up/down-cursor).

In the following **Directory (Name List)** screen, you can make a call to the selected party by pressing  or **Call** soft key. If two or more telephone numbers are assigned to an entry, a top priority telephone number will be dialed.



STEP 6: To display the detailed data for a specific name, press **Detail** soft key while the name is highlighted.

**Note:** If two or more telephone numbers are assigned to an entry, a top priority telephone number is automatically selected when the Detail screen appears.

In the following **Detail** screen, you can make a call to the selected number by pressing  or **Call** soft key.





- **To Search by Telephone Number**

STEP 1: Open the **Directory** screen (see [TO ADD NEW DATA](#)).

STEP 2: Select **1 Search**.

Select an item by either of the following operations.

- Highlight an item by using or **UP/DOWN** soft key, and then press , or **OK** soft key.
- Press **1** key.



STEP 3: Select **3 Tel Number**.

Select an item by either of the following operations.

- Highlight an item by using or **UP/DOWN** soft key, and then press , or **OK** soft key.
- Press **3** key.

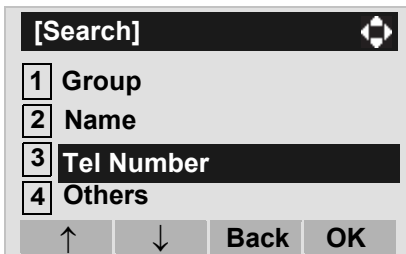

STEP 4: Enter a target telephone number.

After entering the number, press or **OK** soft key.

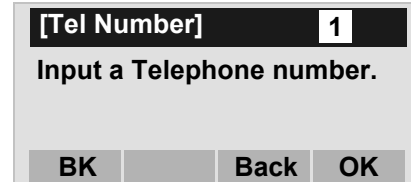

**Note:** Even if the telephone number is not entered to the end, you can search for a telephone number.

STEP 5: Select a target name by pressing .

In the following **Directory (Name List)** screen, you can make a call to the selected party by pressing or **Call** soft key. If two or more telephone numbers are assigned to an entry, a top priority telephone number will be dialed.



**Note:** If there is no entry corresponding to the entered number, "No data" is issued on the screen.

STEP 6: To display the detailed data for a specific name, press **Detail** soft key while the name is highlighted.

**Note:** If two or more telephone numbers are assigned to an entry, a top priority telephone number is automatically selected when the Detail screen appears.

In the following **Detail** screen, you can make a call to the selected number by pressing  or **Call** soft key.



- **To Search by Memory ID**

STEP 1: Open the **Directory** screen (see [TO ADD NEW DATA](#)).

STEP 2: Select **1 Search**.

Select an item by either of the following operations.

- Highlight an item by using or **UP/DOWN** soft key, and then press , or **OK** soft key.
- Press **1** key.



STEP 3: Select **4 Others**.

Select an item by either of the following operations.

- Highlight an item by using or **UP/DOWN** soft key, and then press , or **OK** soft key.
- Press **4** key.



STEP 4: Select **1 Memory ID**.

Select an item by either of the following operations.

- Highlight an item by using or **UP/DOWN** soft key, and then press , or **OK** soft key.
- Press **1** key.

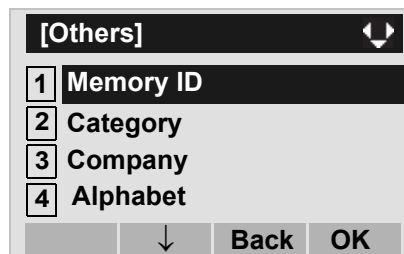



STEP 5: Enter a memory number (0-499).

After entering the memory number, press or **OK** soft key.

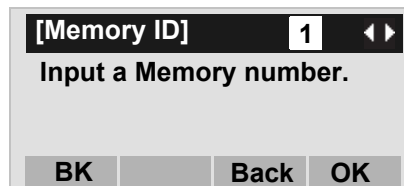
The list of memory numbers will be displayed, with the entered memory number or the number closest to the entered number in front.



STEP 6: Select a target name by pressing  (Up/down-cursor).

In the following **Directory (Name List)** screen, you can make a call to the selected party by pressing  or **Call** soft key. If two or more telephone numbers are assigned to an entry, a top priority telephone number will be dialed.

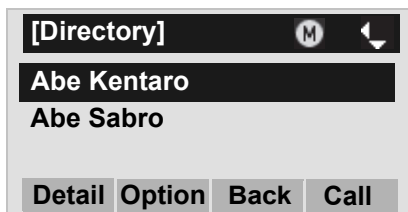

**Note:** If no data exists in Directory, "No data" is issued on the screen.

STEP 7: To display the detailed data for a specific name, press **Detail** soft key while the name is highlighted.

**Note:** If two or more telephone numbers are assigned to an entry, a top priority telephone number is automatically selected when the Detail screen appears.

In the following **Detail** screen, you can make a call to the selected number by pressing  or **Call** soft key.



- **To Search by Category**

STEP 1: Open the **Directory** screen (see [TO ADD NEW DATA](#)).

STEP 2: Select **1 Search**.

Select an item by either of the following operations.

- Highlight an item by using or **UP/DOWN** soft key, and then press , or **OK** soft key.
- Press **1** key.



STEP 3: Select **4 Others**.

Select an item by either of the following operations.

- Highlight an item by using or **UP/DOWN** soft key, and then press , or **OK** soft key.
- Press **4** key.

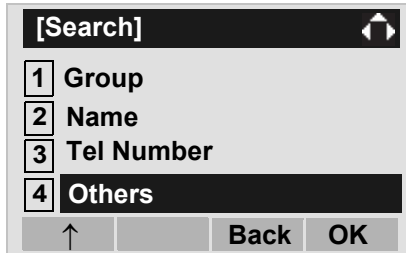

STEP 4: Select **2 Category**.

Select an item by one of the following operations.

- Highlight an item by using or **UP/DOWN** soft key, and then press , or **OK** soft key.
- Press **2** key.

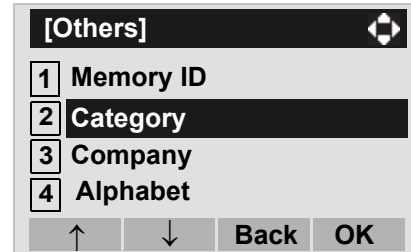

STEP 5: Select a desired category.

In this example, **1 Company** is selected.

Select an item by one of the following operations.

- Highlight an item by using or **UP/DOWN** soft key, and then press or **OK** soft key.
- Press **1** key, and then press or **OK** soft key.

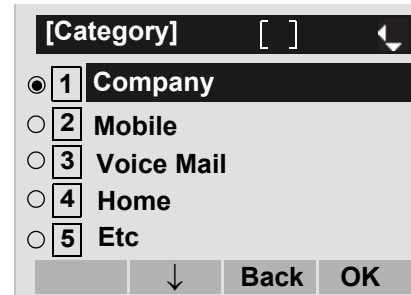

STEP 6: Select a target name by pressing .

In the following **Directory (Name List)** screen, you can make a call to the selected party by pressing  or **Call** soft key. If two or more telephone numbers are assigned to an entry, a top priority telephone number will be dialed.



**Note:** If there is no entry corresponding to the selected category, "No data" is issued on the screen.

STEP 7: To display the detailed data for a specific name, press **Detail** soft key while the name is highlighted.

**Note:** If two or more telephone numbers are assigned to an entry, a top priority telephone number is automatically selected when the Detail screen appears.

In the following **Detail** screen, you can make a call to the selected number by pressing  or **Call** soft key.



- **To Search by Company Name**

STEP 1: Open the **Directory** screen (see [TO ADD NEW DATA](#)).

STEP 2: Select **1 Search**.

Select an item by either of the following operations.

- Highlight an item by using or **UP/DOWN** soft key, and then press , or **OK** soft key.
- Press **1** key.



STEP 3: Select **4 Others**.

Select an item by either of the following operations.

- Highlight an item by using or **UP/DOWN** soft key, and then press , or **OK** soft key.
- Press **4** key.



STEP 4: Select **3 Company**.

Select an item by either of the following operations.

- Highlight an item by using or **UP/DOWN** soft key, and then press , or **OK** soft key.
- Press **3** key.

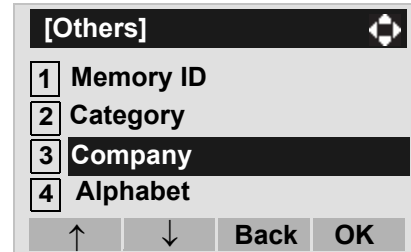

STEP 5: Enter a company name.

After entering the name, Press or **OK** soft key.



**Note:** A distinction is made between upper case and lower case characters. For example, "Ken Kobus" and "ken kobus" are distinguished as different character strings.

**Note:** A blank space is also distinguished while searching database for a name.

**Note:** Even if the name is not entered to the end, you can search for a name.

**Note:** Up to 32 characters can be entered as a company name. For details on character entry method, see [HOW TO INPUT CHARACTERS](#).

STEP 6: Select a target name by pressing .

In the following **Directory (Name List)** screen, you can make a call to the selected party by pressing  or **Call** soft key. If two or more telephone numbers are assigned to an entry, a top priority telephone number will be dialed.

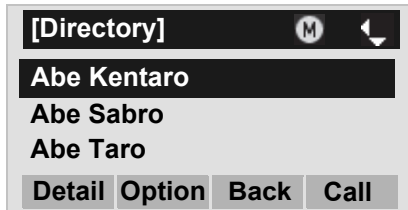

**Note:** If there is no entry corresponding to the selected Company, "No data" is issued on the screen.

STEP 7: To display the detailed data for a specific name, press **Detail** soft key while the name is highlighted.

**Note:** If two or more telephone numbers are assigned to an entry, a top priority telephone number is automatically selected when the Detail screen appears.

In the following **Detail** screen, you can make a call to the selected number by pressing  or **Call** soft key.







- **To Search by Alphabet**

STEP 1: Open the **Directory** screen (see [TO ADD NEW DATA](#)).

STEP 2: Select **1 Search**.



Select an item by either of the following operations.

- Highlight an item by using  or **UP/DOWN** soft key, and then press ,  or **OK** soft key.
- Press **1** key.



STEP 3: Select **4 Others**.

Select an item by either of the following operations.

- Highlight an item by using  or **UP/DOWN** soft key, and then press ,  or **OK** soft key.
- Press **4** key.

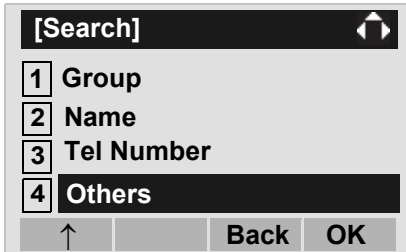

STEP 4: Select **4 Alphabet**.

Select an item by either of the following operations.

- Highlight an item by using  or **UP/DOWN** soft key, and then press ,  or **OK** soft key.
- Press **4** key.

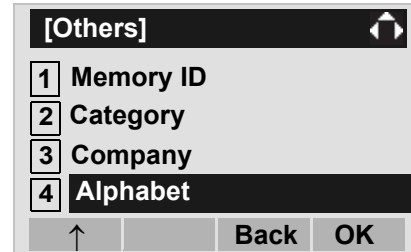

STEP 5: Select a desired group of alphabets.

In this example, **1 ABC** is selected.

Select an item by one of the following operations.

- Highlight an item by using  or **UP/DOWN** soft key, and then press ,  or **OK** soft key.
- Press **0** key, and then press  or **OK** soft key.



**Note:** Select \* **Others** to find names which begin with a character other than alphabet such as numerics or symbols.

STEP 6: Select a target name by pressing . In the following **Directory (Name List)** screen, you can make a call to the selected party by pressing or **Call** soft key. If two or more telephone numbers are assigned to an entry, a top priority telephone number will be dialed.

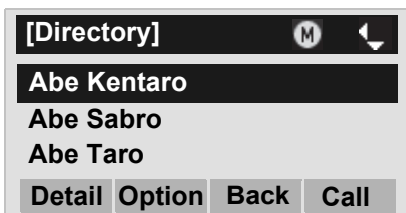

**Note:** If there is no entry corresponding to the group of alphabets, "No data" is issued on the screen.

STEP 7: To display the detailed data for a specific name, press **Detail** soft key while the name is highlighted.

**Note:** If two or more telephone numbers are assigned to an entry, a top priority telephone number is automatically selected when the Detail screen appears.

In the following **Detail** screen, you can make a call to the selected number by pressing or **Call** soft key.



## TO MAKE A CALL FROM DIRECTORY



### DT830

**Note:** While Directory screen is being displayed, you cannot make a call by dialing a telephone number.

- **To Make a Call from Name List Screen**

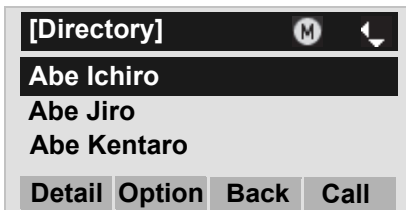
STEP 1: Display the **Directory (Name List)** screen for a target party (see [TO FIND REGISTERED DATA](#)).



STEP 2: Select a target name and then make a call. Select a target name by pressing , and then press  or **Call** soft key to make a call to the selected party.



**Note:** If multiple telephone numbers are registered to a target party, a call is made to the first priority telephone number.



- **To Make a Call from Detail Screen**

STEP 1: Display the **Detail** screen for a target party (see [TO FIND REGISTERED DATA](#)).

**Note:** If two or more telephone numbers are assigned to an entry, a top priority telephone number is automatically selected when the Detail screen appears.



STEP 2: Select a target telephone number and then make a call.

Select a target telephone number by pressing  or **UP/DOWN** soft key, and then press  or **Call** soft key to make a call to the selected number.





## TO ADD PREFIX TO NUMBER **DT830**

### • To Set Prefix

When making a call, a prefix can be added to telephone numbers to be dialed. Prefixes need to be set in advance.



STEP 1: Display the **Menu** screen, and select **Setting**.

STEP 2: Select **1 User Setting**.

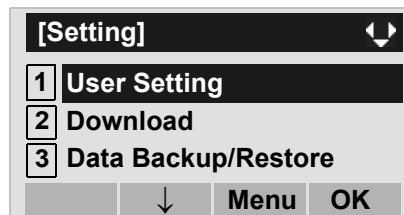
- Select an item by either of the following operations.
- Highlight an item by using  or **UP/DOWN** soft key, and then press ,  or **OK** soft key.
  - Press **1** key.



STEP 3: Select **2 Talk**.

- Select an item by either of the following operations.
- Highlight an item by using  or **UP/DOWN** soft key, and then press ,  or **OK** soft key.
  - Press **2** key.

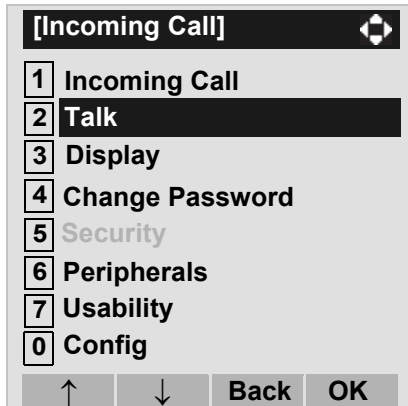

STEP 4: Select **5** **Prefix**.

Select an item by either of the following operations.

- Highlight an item by using or **UP/DOWN** soft key, and then press , or **OK** soft key.
- Press **5** key.



STEP 5: Select **1** **Prefix 1**.

Select an item by either of the following operations.

- Highlight an item by using or **UP/DOWN** soft key, and then press , or **OK** soft key.
- Press **1** key.

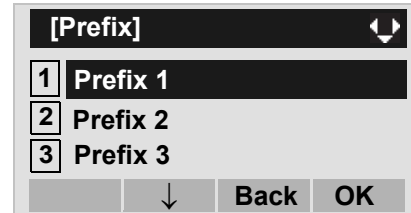

STEP 6: Enter a prefix by using the digit keys.

After entering the prefix, press or **OK** soft key.

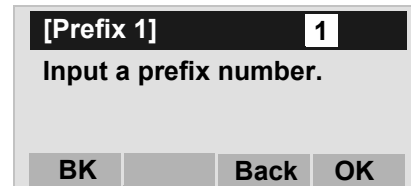

STEP 7: The display goes back the Prefix screen at STEP 5. If multiple prefixes need to be set, repeat STEP 6 and STEP 7. In that case, select **2** **Prefix 2** and **3** **Prefix 3**.

**Note:** A maximum of 10 digits (0-9, \* and #) can be set as a prefix.

**Note:** When prefix is added, up to 32 digits including the prefix can be sent as dial number.

## • To Add Prefix When Making A Call

STEP 1: Display the **Name List** screen for a target party (see [TO FIND REGISTERED DATA](#)).





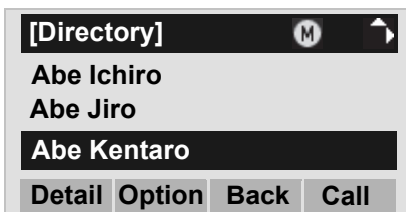

STEP 2: Select a target name and display Sub Menu.  
Select a target name by pressing , and then press **HELP** key or **Option** soft key.



**Note:** If multiple telephone numbers are registered to a target party, a call is made to the first priority telephone number.

STEP 3: Select **1 Prefix**.

Select an item by one of the following operations.

- Highlight an item by using  or **UP/DOWN** soft key, and then press ,  or **OK** soft key.
- Press **1** key, and then press ,  or **OK** soft key.



STEP 4: Predetermined prefixes are displayed. Select a prefix and then press  or **OK** soft key to make a call.

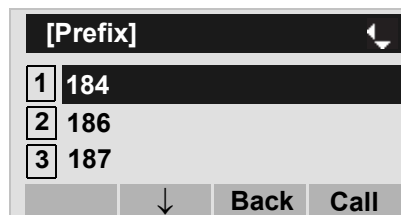

## TO EDIT DIRECTORY DATA **DT830**

STEP 1: Display the **Name List** screen for a target party (see [TO FIND REGISTERED DATA](#)).





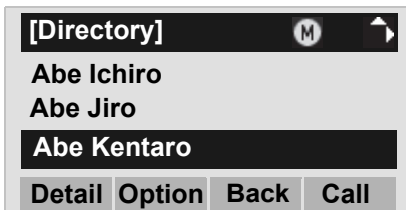

STEP 2: Select a target name and display Sub Menu. Select a target name by pressing , and then press **HELP** key or **Option** soft key.



STEP 3: Select **4 Edit**.

Select an item by one of the following operations.

- Highlight an item by using  or **UP/DOWN** soft key, and then press ,  or **OK** soft key.
- Press **4** key, and then press ,  or **OK** soft key.

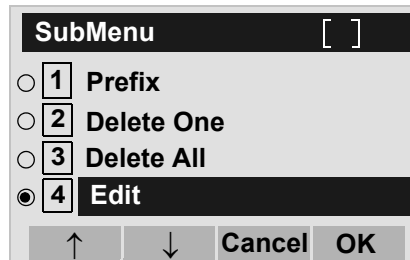

STEP 4: On the **Edit** screen, the detailed data for the selected name is displayed. Modify the necessary data by referring to [TO ADD NEW DATA](#).



After the data modification is complete, press **Save** soft key on the Edit screen.



## TO DELETE ALL DATA **DT830**

STEP 1: Open the **Directory** screen (see [TO ADD NEW DATA](#)).

STEP 2: Select **0 Delete All**.

- Select an item by either of the following operations.
- Highlight an item by using , and then press ,  or **OK** soft key.
  - Press **0** key.



STEP 3: Press  or **OK** soft key to delete all the data.



**Note:** To cancel the data deletion, press  or **Back** soft key.

STEP 4: After all the directory data is deleted, the dis-

play changes as follows:



STEP 5: Press  or **OK** soft key.



## TO DELETE SPECIFIC DATA **DT830**

STEP 1: Display the **Name List** screen for a target party (see [TO FIND REGISTERED DATA](#)).







STEP 2: Select a name to be deleted and display Sub Menu.

Select a target name by pressing , and then press **Help** key or **Option** soft key.



STEP 3: Select **2 Delete One**.

Select an item by either of the following operations.

- Highlight an item by using  or **UP/DOWN** soft key, and then press ,  or **OK** soft key.
- Press **2** key, and then press ,  or **OK** soft key.

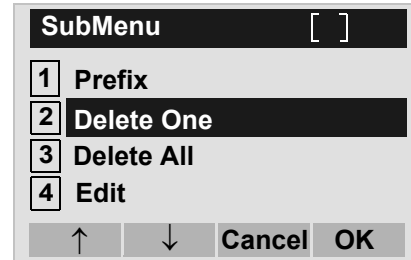

STEP 4: The following confirmation message appears. Press  or **OK** soft key to delete the appropriate directory data.



**Note:** To cancel the data deletion, press  or **Back** soft key.

STEP 5: After the appropriate directory data is deleted, the display changes as follows:

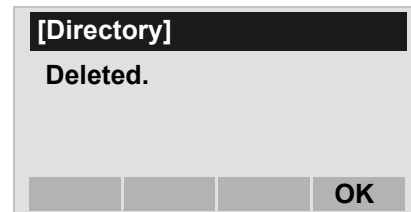

STEP 6: Press  or **OK** soft key.

# 7. CALL HISTORY OPERATION

---

This chapter explains the Call History feature of the terminal. By using Call History, you can make a call with simple operation.

Call History feature allows the telephone to register up to 50 records (for DT830 Series)/10 records (for DT430 Series) into its memory. If exceeding 50 records/10 records, a record will be deleted in order of occurrence.

## FOR DT830 SERIES

- TO VIEW CALL HISTORY
- TO MAKE A CALL FROM CALL HISTORY
- TO ADD CALL HISTORY DATA TO DIRECTORY
- TO EDIT DIRECTORY DATA FROM CALL HISTORY
- TO DELETE ALL DATA
- TO DELETE SPECIFIC DATA

## FOR DT430 SERIES

- TO VIEW CALL HISTORY
- TO MAKE A CALL FROM CALL HISTORY
- TO DELETE ALL DATA
- TO DELETE SPECIFIC DATA

**Note:** Register call history data to Personal Directory as necessary. Call History data will be cleared when powering off the telephone. However, call history data can be backed up to your PC. About Backup/Restore, see “TO BACKUP PERSONAL SETTINGS” or “TO RESTORE PERSONAL SETTINGS” in “3.TERMINAL SETUP”.

**Note:** The call history data that is stored in the memory of each telephone cannot be added to Phonebook (both System Phonebook and Local Phonebook) controlled by the system.

## 7.1 FOR DT830 SERIES

### TO VIEW CALL HISTORY **DT830**

STEP 1: Display the **Menu** screen, and select **History**.

STEP 2: Select a kind of calls.

In this example, **3 Incoming** is selected.

Select an item by either of the following operations.

- Highlight an item by using  or **UP/DOWN** soft key, and then press  or **OK** soft key.
- Press **3** key.

Item	Description
Missed	Display the history of unanswered (terminated to the My Line) incoming calls.
Outgoing	Display the history of outgoing calls.
Incoming	Display the history of answered and unanswered (terminated to the My Line) incoming calls.

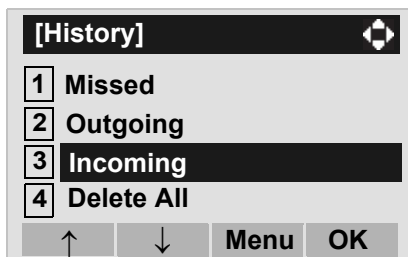

STEP 3: The history data of the last received call is displayed.

If two or more records exist, use  or **UP/DOWN**

soft key to display the next/former records.

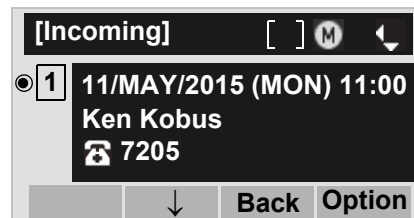

**Note:** For unanswered incoming calls,  will be displayed on the left of the name.

**Note:** If you make/answer a call to/from the telephone number which is registered to Personal Directory, the corresponding name will be displayed as call history data.

**Note:** If there is no history data, "No data" will be displayed on LCD.

**Note:** To go back to former menu (STEP 3), press  or **Back** soft key.

## TO MAKE A CALL FROM CALL HISTORY **DT830**

**Note:** While the history data is displayed, you cannot make a call by dialing a telephone number.

### (CASE 1)

STEP 1: Display call history data of a target telephone number (see [TO VIEW CALL HISTORY](#)).

The following is an example when a history data of Incoming Calls is displayed.

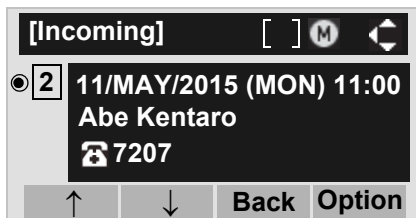

STEP 2: Press  key to make a call to the telephone number.

### (CASE 2)

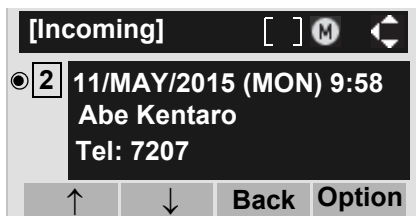

STEP 1: Display call history data of a target telephone number (see [TO VIEW CALL HISTORY](#)).

The following is an example when a history data of Incoming Calls is displayed.

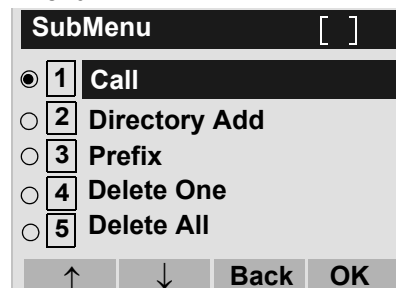

STEP 2: On the above screen, press **Help** key or **Option** soft key to display the following Sub Menu.



STEP 3: To make a call, select **1 Call**, and then press ,  or **OK** soft key.

**Note:** When making a call from Call History, a prefix can be added to the dial number. In that case, select **3 Prefix** on the SubMenu (indicated at STEP 2 of CASE 2) to display the Prefix screen. On the Prefix screen, choose a prefix to be added to the dial number. Also, prefixes need to be set in advance. For details on setting of prefix, see [TO ADD PREFIX TO NUMBER](#) in Chapter 6 Directory Operation.

## TO ADD CALL HISTORY DATA TO DIRECTORY DT830

STEP 1: Display call history data of a target telephone number (see [TO VIEW CALL HISTORY](#)).

The following is an example when history data of an Incoming Call is displayed.



Press **Help** key or **Option** soft key while displaying the call history data for the target telephone number.

STEP 2: The following Sub Menu is displayed. Select **2 Directory Add**.

- Select an item by either of the following operations.
- Highlight an item by using or **UP/DOWN** soft key, and then press , or **OK** soft key.
  - Press **2** key, and then press , or **OK** soft key.

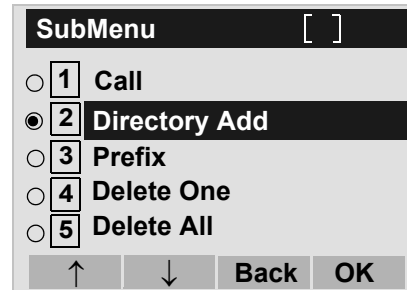

STEP 3: Select **1 New**.

- Select an item by either of the following operations.
- Highlight an item by using or **UP/DOWN** soft key, and then press , or **OK** soft key.
  - Press **1** key.



STEP 4: Select a category.

- In this example, **1 Company** is selected.
- Select an item by either of the following operations.
- Highlight an item by using or **UP/DOWN** soft key, and then press or **Next** soft key.
  - Press **1** key, and then press or **Next** soft key.



Selectable categories are as follows:

Category	ICON
Company	
Mobile	
Voice Mail	
Home	
Others	

STEP 5: Select either **1 Disable** or **2 Enable**.

A maximum of four telephone numbers can be set to an entry. If **2 Enable** is selected here, the telephone number which is being edited will be given top priority. In that case, the telephone number is automatically selected when you make a call without specifying a specific telephone number.

Select an item by either of the following operations.

- Highlight an item by using or **UP/DOWN** soft key, and then press or **OK** soft key.
- Press **1** or **2** key, and then press or **OK** soft

key.



STEP 6: The following **Edit** screen is displayed. “31312” has been registered to Tel #1.

See “[TO ADD NEW DATA](#)” in Chapter 6 Directory Operation, and register detailed data (such as name, group, etc) to directory.

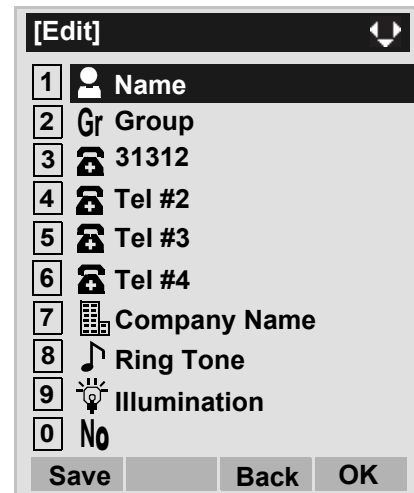

**Note:** If the corresponding data is not stored in the directory, only the telephone number will be displayed as Tel #1.

**Note:** If the corresponding data has already stored in the directory, the detailed data (such as name group, etc.) is displayed.

## TO EDIT DIRECTORY DATA FROM CALL HISTORY **DT830**

STEP 1: Display call history data of a target telephone number (see [TO VIEW CALL HISTORY](#)).

The following is an example when history data of an Incoming Call is displayed.

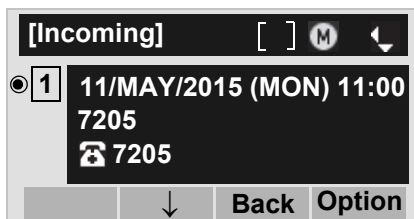

Press **Help** key or **Option** soft key while displaying the call history data for the target telephone number.

STEP 2: The following Sub Menu is displayed. Select **2 Directory Add**.

Select an item by either of the following operations.

- Highlight an item by using or **UP/DOWN** soft key, and then press , or **OK** soft key.
- Press **2** key, and then press , or **OK** soft key

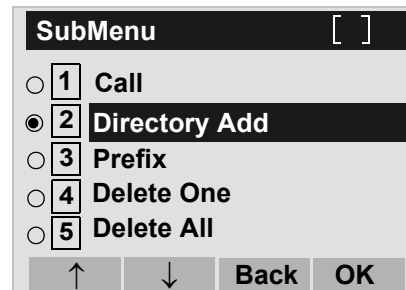

STEP 3: Select **2 Addition**.

Select an item by either of the following operations.

- Highlight an item by using or **UP/DOWN** soft key, and then press , or **OK** soft key.
- Press **2** key.

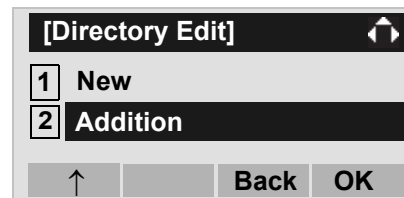

STEP 4: Select a search method.

See [TO FIND REGISTERED DATA](#) for the procedure of the searching method.

In this example, **1 Group** is selected.

Select an item by either of the following operations.

- Highlight an item by using or **UP/DOWN** soft key, and then press , or **OK** soft key.
- Press **1** key.



**STEP 5:** Select a group.

In this example, **2** **Colleagues** is selected.

Select an item by either of the following operations.

- Highlight an item by using or **UP/DOWN** soft key, and then press or **OK** soft key.
- Press **2** key, and then press **OK** soft key

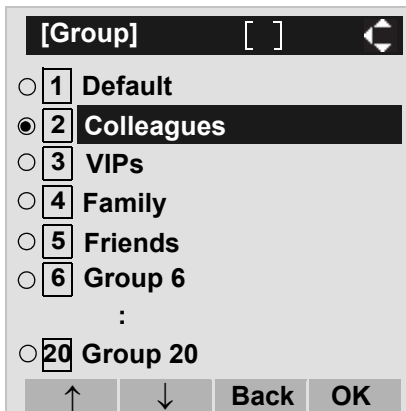

**STEP 6:** The names belonging to Colleagues are displayed as the following example.

Select a name and then press or **OK** soft key.



**Note:** If there is no corresponding data, "No data" will be displayed on LCD.

**STEP 7:** Select a registration destination. In this example, "7205" will be added to Tel #2.

Select an item by either of the following operations.

- Highlight an item by using or **UP/DOWN** soft key, and then press or **OK** soft key.
- Press **1** - **4** key, and then press or **OK** soft key.

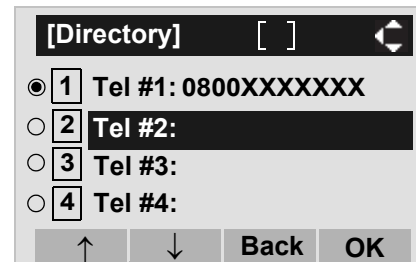



**Note:** In this example, a mobile telephone number "0800XXXXXXX" has already been registered to Tel #1. If you select Tel #1 here, "0800XXXXXXX" will be overwritten with "7205".



STEP 8: Select a Category to which the telephone number belongs.

In this example, **1 Company** is selected.

Select an item by either of the following operations.



- Highlight an item by using  or **UP/DOWN** soft key, and then press  or **OK** soft key.
- Press **1** key, and then press  or **OK** soft key.



STEP 9: Select either **1 Disable** or **2 Enable**.

A maximum of four telephone numbers can be set to an entry. If **2 Enable** is selected here, the telephone number which is being edited will be given top priority. In that case, the telephone number is automatically selected when you make a call without specifying a specific telephone number.

Select an item by either of the following operations.

- Highlight an item by using  or **UP/DOWN** soft key, and then press  or **OK** soft key.
- Press **1** or **2** key, and then press  or **OK** soft key.

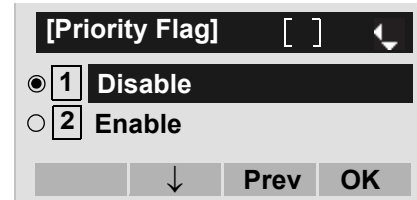

STEP 10: The display moves to the **Edit** screen of Directory. “7205” has been registered to Tel #2. See [TO EDIT DIRECTORY DATA](#) in Directory Operation, and edit the data as necessary.

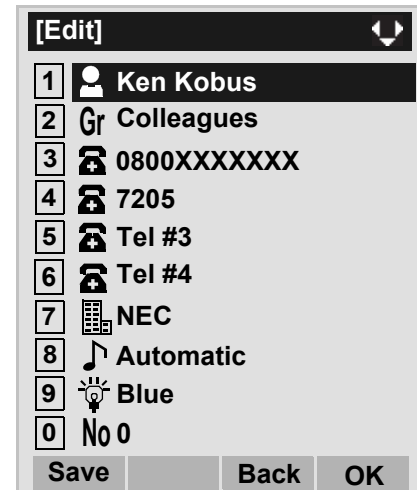

## TO DELETE ALL DATA **DT830**

STEP 1: Display the **Menu** screen, and select **History**.

STEP 2: Select **4 All Delete**.

Select an item by either of the following operations.

- Highlight an item by using  or **UP/DOWN** soft key, and then press  or **OK** soft key.
- Press **4** key.

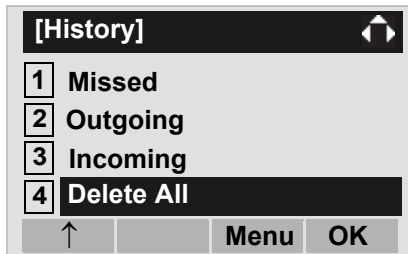

STEP 3: The following confirmation message appears. Press  or **OK** soft key to delete all the data.



**Note:** To cancel the data deletion, press  or **Back** soft key.

STEP 4: After all history data is deleted, the display changes as follows. Press  or **OK** soft key.



## TO DELETE SPECIFIC DATA **DT830**

STEP 1: Display call history data of a target telephone number referring to **TO VIEW CALL HISTORY**.

The following is an example when a history data of Incoming Calls is displayed.

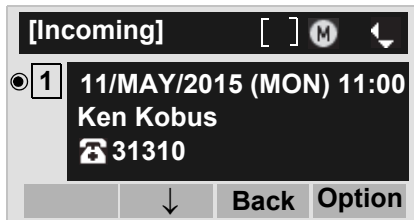

Press **Help** key or **Option** soft key while displaying the call history data for the target telephone number.

STEP 2: The following Sub Menu is displayed. Select **4 Delete One**.

Select an item by either of the following operations.

- Highlight an item by using or **UP/DOWN** soft key, and then press , or **OK** soft key.
- Press **4** key, and then press , or **OK** soft key.

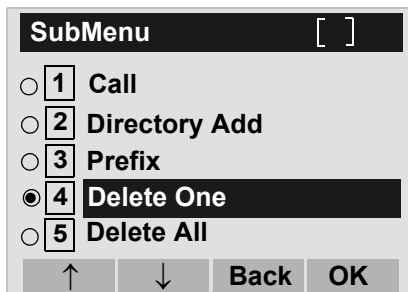

**Note:** By selecting **5 Delete All**, all records of Incoming Call can be deleted.

STEP 3: The following confirmation message appears. Press or **OK** soft key to delete the appropriate history data.

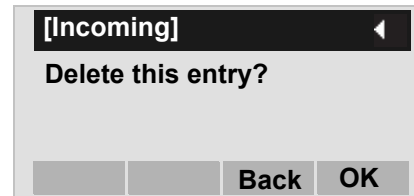

**Note:** To cancel the data deletion, press or **Back** soft key.

STEP 4: After the appropriate call history data is deleted, the display changes as follows. Press or **OK** soft key.

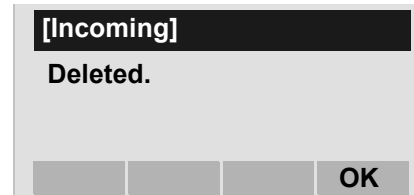

## 7.2 FOR DT430 SERIES

### TO VIEW CALL HISTORY **DT430**

#### • TO VIEW DATA OF INCOMING CALL/ OUTGOING CALL

STEP 1: While indicating the current time on LCD, press **Menu** key to open the **Menu** screen.

**Note:** This feature is for DT830 Series and DT430 Series. The following is an example of LCD display of DT430 Series.

DT430 Series

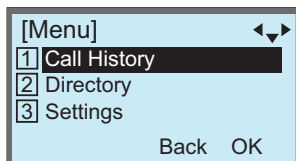

STEP 2: Select **1 Call History**.

Select an item by either of the following operations.

- Highlight an item by using and then press or **OK** soft key.
- Press **1** key.

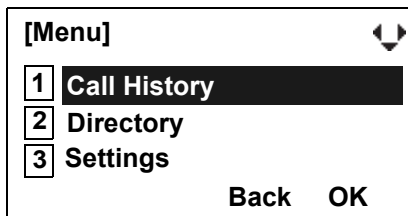

STEP 3: Select a kind of calls.

In this example, **1 Incoming Calls** is selected.

Select an item by either of the following operations.

- Highlight an item by using and then press , or **OK** soft key.
- Press **1** key.

Item	Description
Incoming Calls	To view the history of incoming calls.
Outgoing Calls	To view the history of outgoing calls.

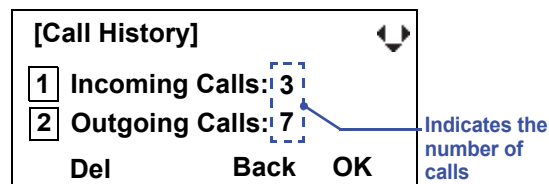

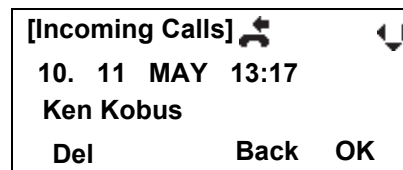

STEP 4: The history data of the last received call is displayed. If name information of the caller exists, the name is displayed as follows:

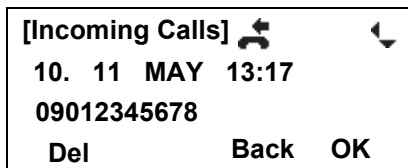

**Note:** There are two types of incoming call: Answered Call and Missed Call. When history data of missed calls is displayed on the screen, appears on the top line of the screen.

STEP 5: To view the telephone number of the caller, press .



**Note:** If two or more records exist, use  to display the next/former records (or pressing an appropriate digit key). For example, press “0” key to display the tenth record.

**Note:** If no history data is saved, "No data" will be displayed on LCD.

**Note:** To go back to name display, press  key. For the telephone without the cursor key, switching between “name” and “telephone number” cannot be performed.



**Note:** To go back to former menu (STEP 3), press **Back** soft key.

**Note:** If the telephone number of the caller is not received (due to Caller ID blocking, public phone or out of area, etc.), “Private” is displayed on LCD.

• **TO VIEW DATA OF MISSED CALL ONLY**

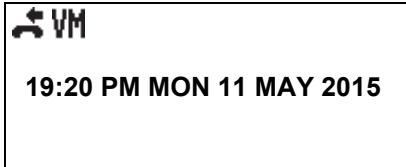
STEP 1: While indicating the current time on LCD, press  key to open **Shortcut** screen.



**Note:**  indicates that the telephone has received a missed call.  
 indicates that the telephone has received a voice mail.

STEP 2: Select **1 Missed Calls**.

Select an item by either of the following operations.

- Highlight an item by using , and then press ,  or **OK** soft key.
- Press **1** key.

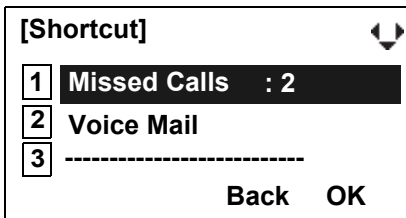

**Note:** When voice mail service is not used, "**2** -----" is displayed instead of "**2** Voice Mail".

STEP 3: The history data of the last received call is displayed. If name information of the caller exists, the name is displayed as follows:

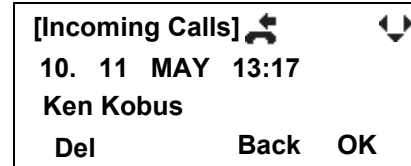

**Note:** If two or more records exist, use  key to display the next/former records (or pressing an appropriate digit key). For example, press "0" key to display the tenth record.

**Note:** To go back to former menu (STEP 3), press **Back** soft key.

**Note:** If the telephone number of the caller is not received (due to Caller ID blocking, public phone or out of area, etc.), "Private" is displayed on LCD.

## TO MAKE A CALL FROM CALL HISTORY **DT430**

- **FOR DT430 SERIES**

STEP 1: Display the call history data of the target telephone number (see [TO VIEW CALL HISTORY](#)).

The following is an example when the history data of an incoming call is displayed.

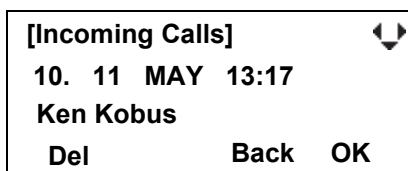



STEP 2: Press  key while the history data for the target telephone number is displayed on LCD.

**Note:** While the history data is displayed, you cannot make a call by dialing a telephone number.

## TO DELETE ALL DATA **DT430**

STEP 1: Select **1** **Call History** on the Menu screen.

Select an item by either of the following operations.

- Highlight an item by using , and then press ,  or **OK** soft key.
- Press **1** key.

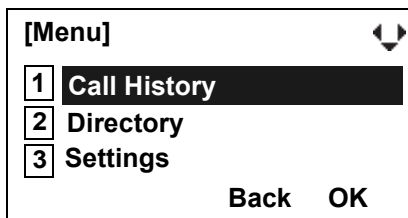

STEP 2: Select a kind of calls.

In this example, **1** **Incoming Calls** is selected.

Select an item by either of the following operations.

- Highlight an item by using , and then press ,  or **OK** soft key.
- Press **1** key.

Item	Description
Incoming Calls	To delete all the history data of incoming calls.
Outgoing Calls	To delete all the history data of outgoing calls.

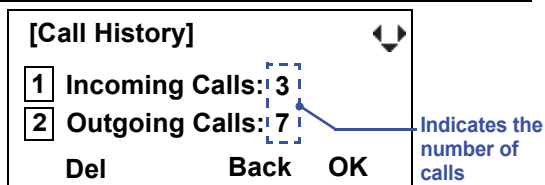

STEP 3: Press **Del** soft key. The display changes as follows:

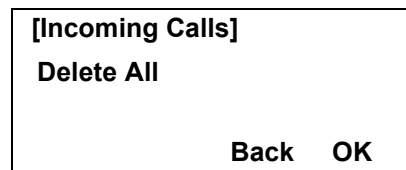

**Note:** To cancel the data deletion, press  or **Back** soft key.

STEP 4: Press  or **OK** soft key to delete all the history data of selected call type.



## TO DELETE SPECIFIC DATA **DT430**

STEP 1: Display the call history data which you want to delete (see [TO VIEW CALL HISTORY](#)). The following is an example when the history data of an incoming call is displayed.

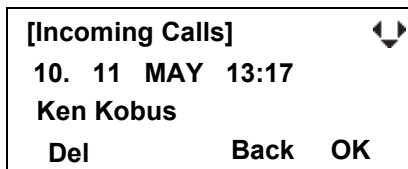

STEP 2: Press **Del** soft key. The display changes as follows:

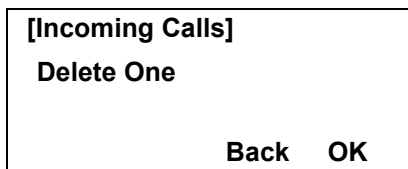

**Note:** To cancel the data deletion, press  or **Back** soft key.

STEP 3: Press  or **OK** soft key to delete the selected history data.

# 8. SPECIFICATIONS

## TECHNICAL SPECIFICATIONS

The following shows the technical specifications of DT430/DT410 Series.



	8LD	24D/12D	6DE	2E
Display (LCD)	168 × 58 dot multi display	168 × 58 dot	24-digit x 3-line LCD	None
Display Color	Monochrome (with no shades of gray)			-
Character on LCD	Characters supported by Multilingual Display			-
Programmable Key	Key data is displayed on LCD. 8LD : 32 (8 X 4) / 24/12 Keys [2-color (red and green) LED]		6 Keys	2 Keys
Fixed Feature Key	10 keys (with Menu/Cursor button)		11 Keys	
Backlight	Display and Digit Key (lit for 10 seconds when you press any key) *For 24D/12D, Display Backlight is optional.		None	
Soft Key	4 Keys			None
Call History	Outgoing Call: 10 records, Incoming Call: 10 records		None	
Smart Device Integration	Supported		Not Supported	
Hands-free	Standard equipment (Half-duplex)			
Headset	HW251N-A10-NE		Not available	
Power Consumption	2.2 [W]	2.0 [W]	1.2 [W]	1.2 [W]
Adapter (optional)	Recording Unit (ADA)/Analog Port Unit (APR)/Wall-mounting kit (WM)/Line Feature Key Unit (8LK)/Side panel/Bluetooth® Connection Adapter (BCA)		Wall-mounting kit (WM)/Digit-key Set Unit/Side panel	
Color	Black/White		Black	
Dimension (W×D×H)	182(W) × 264(D) × 109(H) [mm]	182(W) × 258(D) × 109(H) [mm]	182(W) × 224(D) × 109(H) [mm]	
Weight	1.2kg	1.1 kg	1.0 kg	0.9 kg
Environmental	Operational Temperature range = 0 to 40 °C (Storage temperature range = -20 to 60 °C) Humidity = 10 to 90% RH (non condensing)			

The following shows the technical specifications of DT830 Series.

	8LD/8LDG	24D/12D
Display (LCD)	224 x 96 dot multi display	224 x 96 dot
Display Color	Gray scale (with 8 shades of gray)	
Programmable Key	Key data is displayed on LCD. 8LD (32 (8 X 4) Keys)	
Fixed Feature Key	10 keys (with Menu/Cursor/Security button)	
Backlight	Display and Digit Key (lit for 10 seconds when operating)	
Soft Key	4 Keys	
Directory	500 records	
Call History	Outgoing Call: 50 records, Incoming Call: 50 records	
XML Browser	Available	
Hands-free	Standard equipment (Full-duplex), Wide-band	
Headset	HW251N-A10-NE/WT100-EHS-NE/Voyager Legend CS	
LAN Interface	2-port, 10BASE-T/100BASE-TX/1000BASE-T (8LDG only), Full-duplex/Half-duplex, Auto Negotiation /Fixed	
Voice CODEC	G.711(μ-law, A-law), G.729a, G.722	
IP Address Setting	Sets via DHCP server/Sets Statically	
QoS	ToS (IP Precedence, Diffserv)	
VLAN	Tag VLAN (IEEE802.1Q/p), LLDP-MED	
Security	IEEE802.1x authentication (EAP-MD5, EAPOL Forwarding), SIP&RTP Encryption	
Power Supply	Center Power Supply = IEEE802.3af, Local Power Supply = AC adapter (AC-L UNIT: optional)	
Power Consumption	8LD: 3.7 [W], 8LDG: 4.4 [W]	3.7 [W]
Download	Program/Configuration data/Ringing Tone/Music on Hold/Directory data	
Adapter (Optional)	Recording Unit/Wall-mounting kit/Line Feature Key Unit (8LK)/Side panel/Bluetooth® Connection Adapter (BCA)	
Color	Black/White	Black/White
Dimension (W×D×H)	182(W) × 264(D) × 109(H) [mm]	182(W) × 258(D) × 109(H) [mm]
Weight	1.2 kg	1.1 kg
Environmental	Operational Temperature range = 0 to 40 °C (Storage temperature range = -20 to 60 °C) Humidity = 10 to 90% RH (non condensing)	

# MENU LIST

## MENU LIST FOR DT830 SERIES

Menu Item		Description
With a Home URL registered.		
Menu		Press  to display the <b>Menu</b> screen.
	History	Select this option to view Call History data. Also, you can add the history data to the directory.
	Directory	Select this option to access directory feature. There are three types of directory features as described below: Personal Directory, Phonebook and Corporate Directory. This chapter explains the menu list for Personal Directory feature.
	Service	Select this option to display XML application screen registered in the service URL.
	Setting	Select this option to access user settings.
	Portal	Select this option to display XML application screen registered in the home URL.
Without a Home URL registered.		
Menu		Press  to display the <b>Menu</b> screen.
	History	Select this option to view Call History data. Also, you can add the history data to the directory.
	Directory	Select this option to access directory feature. There are three types of directory features as described below: Personal Directory, Phonebook and Corporate Directory. This chapter explains the menu list for Personal Directory feature.
	Setting	Select this option to access user settings.
	Phone	Select this option to move to the default home screen.

## Menu List For **History**

Menu Item	Description	Default Value
History		
1 Missed	Select this option to view the history of missed calls. You can also make a call from this menu.	-
2 Outgoing	Select this option to view the history of outgoing calls. You can also make a call from this menu.	-
3 Incoming	Select this option to view the history of incoming calls. You can also make a call from this menu.	-
4 Delete All	Select this option to delete all the history data.	-

## Sub Menu

Press **Option** soft key or **Help** key while the history data is displayed.

Menu Item		Description	Default Value
SubMenu			
1	Call	Select this option to make a call to the currently displayed party.	-
2	Directory Add	Select this option to add the currently displayed history data to the personal directory.	-
1	New	Select this option to add call history data to the personal directory.	-
	Category Set	Select this option to specify phone number types (such as Company, Mobile, Voice Mail, Home or Others).	Company
	Priority Flag	Select this option to specify whether to use the priority order of dialing number for call origination.	Disable
	Edit	Select this option to edit the directory data.	-
2	Addition	Select this option to edit the personal directory data from call history.	-
	Directory Search	Select this option to search the personal directory.	-
	Directory	Register the telephone number to the searched directory data.	-
3	Prefix	Select this option to add Prefix to the telephone number and then make a call.	-
4	Delete One	Select this option to delete specific data.	-
5	Delete All	Select this option to delete all history data of a specific call type ("missed", "outgoing" or "incoming")	-

## Menu List For Directory

Menu Item		Description	Default Value
Directory		From <b>Menu</b> screen, select <b>2</b> Directory → <b>1</b> Personal.	-
1	Personal	Select this option to view the Directory controlled by the telephone.	
	1 Search	Select this option to search the personal directory.	-
	1 Group	Select this option to specify a group as a search condition.	-
	2 Name	Select this option to enter the target name and perform a search.	-
	3 Tel Number	Select this option to enter the target telephone number and perform a search.	-
	4 Other	Select this option to perform a search by one of the following conditions.	-
	1 Memory ID	Select this option to search by a memory number.	-
	2 Category	Select this option to search by a category.	-
	3 Company	Select this option to search by a company name.	-
	4 Alphabet	Select this option to search by alphabet.	-
	2 Edit	Select this option to add new data to the personal directory.	-
	1 Name	Select this option to enter a name of the target party to be added to the directory.	-
	2 Group	Select this option to select a group to which the target party belongs.	Default
	3-6 Tel #1-Tel #4	Select this option to enter the telephone number.	-
	Category Set	Select this option to specify phone number types (such as Company, Mobile, Voice Mail, Home or Others).	Company
	Priority Flag	Select this option to specify whether to use the priority order of dialing number for call origination.	Disable
	7 Company Name	Select this option to enter the company name of the target party.	-
	8 Ring Tone	Select a ringer tone type per caller.	Default (follows group settings)
	9 Illumination	Select an illumination pattern (color) of the call indication lamp.	Default (follows group settings)
	0 Memory ID	Select this option to enter a memory number to be assigned to the target party.	-

Menu Item		Description	Default Value
3	Group Setting	Select this option to change a group name.	-
	1. Default	Select a desired group name to be changed.	-
	2. Colleagues		
	3. VIPs		
	4. Family		
	5. Friends		
	6. Group 6 - 20. Group 20		
	1 Name	Select this option to enter a new group name.	-
	2 Ring Tone	Select this option to select a ringer tone type per group.	Default (follows terminal settings)
	3 Illumination	Select this option to select an illumination pattern (color) of the call indication lamp.	Default (follows terminal settings)
	4 Own Number	Select this option to view the number of the telephone itself.	-
0 Delete All	Select this option to delete all the registered directory data.	-	
2 System	Select this option to view the Directory controlled by the system.		
3 Corporate	Select this option to view the Directory controlled by the external XML server.		



## Menu List For **Setting**

Menu Item	Description	Default Value
Setting		
1 User Setting	Select this option to make the user setting of the terminal.	
1 Incoming Call	Select this option to set up for incoming call.	
1 Ring Volume	Not used.	-
2 Offhook Ring	Select this option to specify whether to use Off-hook ringing. (Disable/Enable)	Enable
3 Headset Ring	Select this option to specify whether to use the ringing of headset. (Disable/Enable)	Disable
4 Ring Tone	Select a ringer tone for External Call and Internal Call. (Automatic/Tone Type 1~14/Download 1~3)	Automatic (Tone Type1)
5 Illumination	Select this option to set an illumination pattern for External Call and Internal Call. (Automatic/Disable/Red/Green/Blue/Yellow/Purple/Light Blue/White/Rotation)	Automatic (Red)
6 Headset Ring Volume	Not used.	-
2 Talk	Select this option to set up for telephone conversation.	-
1 RTP Alarm	Select this option to specify whether to use RTP alarm. (Automatic/Disable/Enable)	Automatic
2 DTMF Tone	Select this option to specify whether to use DTMF tone. (Automatic/Disable/Enable)	Automatic
3 Key Touch Tone	Select this option to set key touch tone generated when the digit keys are pressed while the telephone is off-hook. (Automatic/No Tone/Tone/Voice)	Automatic
4 Hold Music	Select a Music on Hold to be heard by the terminal user. (Default/Download)	Default
5 Prefix	Select this option to register Prefix number. (Prefix 1~Prefix 3)	-

Menu Item		Description	Default Value
	<b>3 Display Note 1</b>	Select this option to set up for LCD display.	-
	1 Calender Format	Select this option to set up for calender display format and time display format.	-
	1 Calender Format	Select this option to configure the type of calender display format. (Automatic/Type 1/Type 2/Type 3/Type 4/Type 5)	Automatic (Type 1)
	2 Time Format	Choose between 12-hour and 24-hour clock format.	Automatic (12-hour format)
	2 Local Volume	Specify whether to display the following volume levels: handset receiver volume, speaker volume, ringer tone volume and LCD contrast. (Automatic/Disable/Enable)	Automatic (Enable)
	3 Screen Saver	Select this option to set up Screen Saver related data.	-
	1 Screen Saver Mode	Select this option to specify whether to use Screen Saver. (Disable/Enable)	Disable
	2 Wait Time	Select this option to specify the Wait Time to launch Screen Saver (1-999 min)	120 min
	4 Back Light	Select this option to specify whether to use the backlights of LCD and digit keys. (Disable/Enable)	Automatic (Enable)
	5 Font Size	Select this option to change the displayed character size on the LCD. (Standard (16 dot)/Small (12 dot))	Standard (16 dot)

Menu Item	Description	Default Value
	<p data-bbox="292 232 424 258">6 Language</p> <p data-bbox="576 232 1219 285">Select this option to specify the language to be displayed on LCD.</p> <ul style="list-style-type: none"> <li data-bbox="756 303 1035 329">● <input checked="" type="radio"/> 0 Automatic</li> <li data-bbox="756 329 895 355">○ <input type="radio"/> 1 日本語</li> <li data-bbox="756 355 959 381">○ <input type="radio"/> 2 NEC English</li> <li data-bbox="756 381 1007 406">○ <input type="radio"/> 3 NEC Português</li> <li data-bbox="756 406 970 432">○ <input type="radio"/> 4 NEC Español</li> <li data-bbox="756 432 986 458">○ <input type="radio"/> 5 NEC Français</li> <li data-bbox="756 458 922 483">○ <input type="radio"/> 6 Deutsch</li> <li data-bbox="756 483 938 509">○ <input type="radio"/> 7 ITALIANO</li> <li data-bbox="756 509 959 535">○ <input type="radio"/> 8 Nederlands</li> <li data-bbox="756 535 895 560">○ <input type="radio"/> 9 Norsk</li> <li data-bbox="756 560 895 586">○ <input type="radio"/> 10 Dansk</li> <li data-bbox="756 586 906 612">○ <input type="radio"/> 11 Svensk</li> <li data-bbox="756 612 938 638">○ <input type="radio"/> 12 Ελληνικά</li> <li data-bbox="756 638 906 663">○ <input type="radio"/> 13 English</li> <li data-bbox="756 663 951 689">○ <input type="radio"/> 14 Português</li> <li data-bbox="756 689 916 715">○ <input type="radio"/> 15 Español</li> <li data-bbox="756 715 927 740">○ <input type="radio"/> 16 Français</li> <li data-bbox="756 740 927 766">○ <input type="radio"/> 17 Русский</li> <li data-bbox="756 766 879 792">○ <input type="radio"/> 18 Türk</li> <li data-bbox="756 792 906 817">○ <input type="radio"/> 19 Română</li> <li data-bbox="756 817 890 843">○ <input type="radio"/> 20 Polski</li> <li data-bbox="756 843 906 869">○ <input type="radio"/> 21 Català</li> <li data-bbox="756 869 895 895">○ <input type="radio"/> 22 한국어</li> <li data-bbox="756 895 959 920">○ <input type="radio"/> 23 中文(简体字)</li> <li data-bbox="756 920 959 946">○ <input type="radio"/> 24 中文(繁体字)</li> </ul> <p data-bbox="576 991 1209 1072">* “23. Simplified Chinese” and “24. Traditional Chinese” are available since SV9500 V3, and the terminal firmware version 4.0.0.0 or later.</p>	<p data-bbox="1286 641 1398 666">Automatic</p>

Menu Item		Description	Default Value
	7. Advanced	Sets other data for display.	-
	1.Backlight Fade Control	Sets whether Backlight Fade Control is in service, when turning on/off the backlight of the display. (Disable/Enable)	Enable
	4 Change Password	Select this option to change the password to lock/unlock the telephone.	0000
	5 Security	Not used. *Security key must be programmed in advance. For the programming of Security key, contact the system administrator.	-
	6 Peripherals	Select this option to use peripheral equipment of terminal.	-
	1.USB Memory	Not used.	-
	2.BCA Option	Select this option to configure the BCA.	-
	1.BCA Connection Settings	Select this option to make the BCA connection settings.	-
	1. Auto Connection	Select this option to use Auto Connection. (Disable/Enable)	Enable
	2. Connection Cycle	Select this option to set Bluetooth connection cycle. (3 Seconds/10 Seconds/1 Minute/10 Minutes)	10 Seconds
	2.Interrupt Ringing	Select this option to specify whether to use Interrupt Ringing. (Disable/Enable)	Enable
	3.Smart Device Type	Select this option to set the type of Smart Device. (Type 1/Type 2)	Type 1
	4.Auto Path Switch	Select this option to specify whether to use Auto Path Switch (Disable/Enable)	Enable
	5.Illumination	Select this option to Set the illumination pattern (color) for informing call termination. (Disable/Red/Green/Blue/Yellow/Purple/Light Blue/White/Rotation)	Blue

Menu Item		Description	Default Value
	7. Usability	Select this option to set the operation of Help key while pop-up window is displayed.	-
	1.Help Key Mode	Select this option to set up Help Key Mode (SubMenu/Popup Window)	SubMenu
	0 Setting Reset	Select this option to reset the telephone settings.	-
2 Download		Select this option to set up the file downloading.	-
	1 Download Files	Select this option to download the files for Music on Hold, ringer tone and directory.	-
	1 Hold Music	Select this option to download a file for Music on Hold.	MOH.wav
	2 Ring Tone	Select this option to download files for ringer tones	-
	1. Download 1	Select this option to download files for ringer tone (Download 1).	Melody1.wav
	2. Download 2	Select this option to download files for ringer tone (Download 2).	Melody2.wav
	3. Download 3	Select this option to download files for ringer tone (Download 3).	Melody3.wav
	3 Directory	Select this option to download the directory files.	Directory.csv
	2 Download Address	Select this option to enter an IP address of the FTP/TFTP server.	0.0.0.0
	3 Protocol	Select this option to select a protocol of the server (either FTP or TFTP).	FTP
	4 FTP Settings	Select this option to set necessary data when using FTP service.	-
	1 User ID	Select this option to enter a user ID for downloading via FTP server.	-
2 Password	Select this option to enter a password for downloading via FTP server.	-	
3 Folder	Select this option to specify the directory where the download file is stored.	-	

Menu Item		Description	Default Value
	3 Data Backup/Restore	Select this option to set the data required for the file backup/restore.	-
	1 Data Backup	Select this option to select this option to specify the file name to be backed up.	PersonalData.tgz
	2 Data Restore	Select this option to specify the file name to be restored.	PersonalData.tgz
	3 Server Address	Select this option to enter an IP address of the FTP/TFTP server.	0.0.0.0
	4 Protocol	Select this option to select a protocol of the server (either FTP or TFTP).	FTP
	5 FTP Settings	Set necessary data when using FTP service.	-
	1 User ID	Select this option to enter a user ID for the data backup via FTP server.	-
	2 Password	Select this option to enter a password for data backup via FTP server.	-
	3 Folder	Select this option to specify the destination directory of FTP server.	-

**Note 1:** Before firmware version 3.0.3.0, the menu item of “3 Display” is as follows.

Menu Item		Description	Default Value
	3 Display	Select this option to set up for the LCD display.	-
	1 Time Format	Choose between 12-hour or 24-hour clock format.	Automatic (12-hour format)
	2 Local Volume	Specify whether to display the following volume levels: handset receiver volume, speaker volume, ringer tone volume and LCD contrast.	Automatic (Enable)

## MENU LIST FOR DT430 SERIES

Menu Item	Description
Menu	Press  key while indicating the current time on LCD.
<b>1</b> Call History	Select this option to view call history data.
<b>2</b> Directory	Select this option to access Phonebook feature. For details, see <a href="#">PHONE-BOOK</a> in chapter 5.
<b>3</b> Settings	Select this option to make the user setting of the terminal.

### Menu List For **1** Call History

Menu Item	Description	Default Value
1 Call History		
1 Incoming	Select this option to view the history of incoming calls. You can also make a call from this menu.	-
3 Outgoing	Select this option to view the history of outgoing calls. You can also make a call from this menu.	-

# WEB PROGRAMMING

---

## OUTLINE

Web Programming allows you to configure the terminal settings of the terminal from the PC. An Internet browser (Internet Explorer, etc.) is used to access Web Programming. It is not necessary to install any special application software onto the PC.

**Note:** This feature is only available for DT830 Series.

**Note:** DT830 Series and Web Programming PC needs to be connected to the same network. When downloading the files for Music on Hold, Ringer Tone, and Directory to the terminal, FTP (TFTP server) is required on the network. For details on the FTP service, contact the system administrator.

**Note:** Terminal settings through the Web Programming is available while the DT830 Series logs into the system.

### PC Requirements For Web Programming

Items	Operating Conditions
Operating System	Microsoft® Windows® Vista/Windows® 7/Windows® 8.1/Windows® 10
CPU	Comply with conditions for use of Microsoft® Windows or Microsoft® Internet Explorer.
Memory	
Browser	Microsoft® Internet Explorer 11.0 or later
Monitor	SVGA (minimum: 800 × 600 pixel, recommended: 1024 × 768 pixel)
Others	Mouse, LAN connection port (RJ-45)



## TO LOGIN

Follow the steps below to open the Web Programming.

STEP 1: Start up Internet browser on the PC.

STEP 2: Enter IP address of the target DT830 Series on the address toolbar and then press Enter key.

STEP 3: The Web Programming Login screen appears. Enter a user name (type “USER”) and a password, then click **OK**.



**Note:** Enter the password you assigned on the procedure “TO CHANGE PASSWORD”. “0000” is used as password by the default setting.

**Note:** For IP address of the terminal, contact the system administrator.

**Note:** When the login screen does not appear, check the LAN connection status and entered IP address. If the problem persists, please contact the system administrator.

STEP 4: The following Web Programming **Home** screen appears.

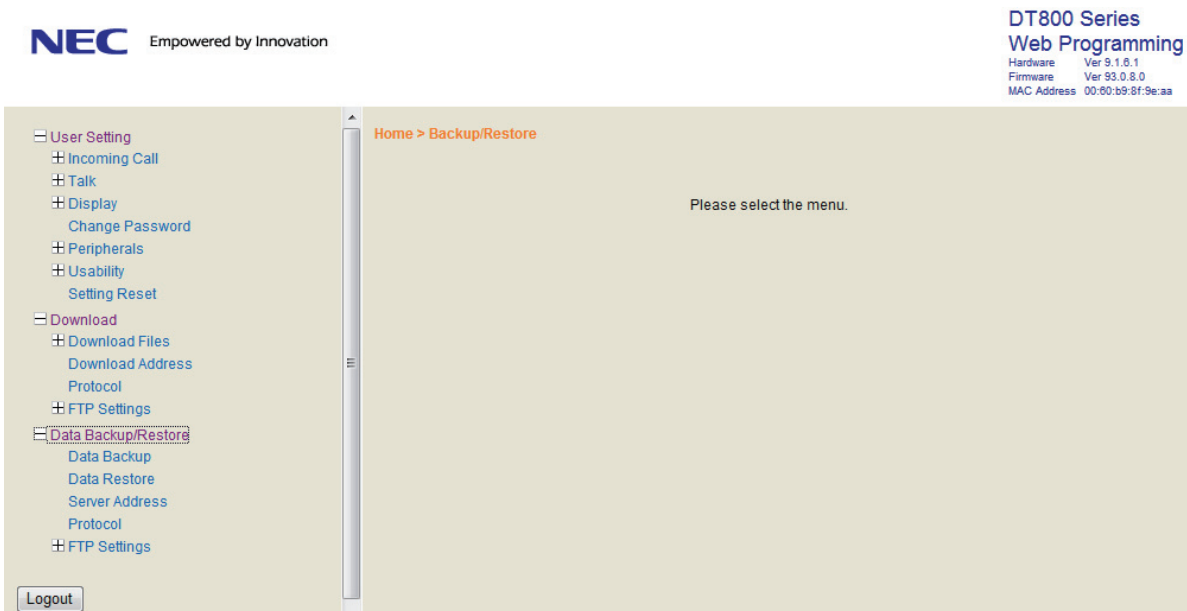

## TO LOGOUT

Follow the steps below to exit the Web Programming.

STEP 1: Click **Logout** at the lower left of the screen.

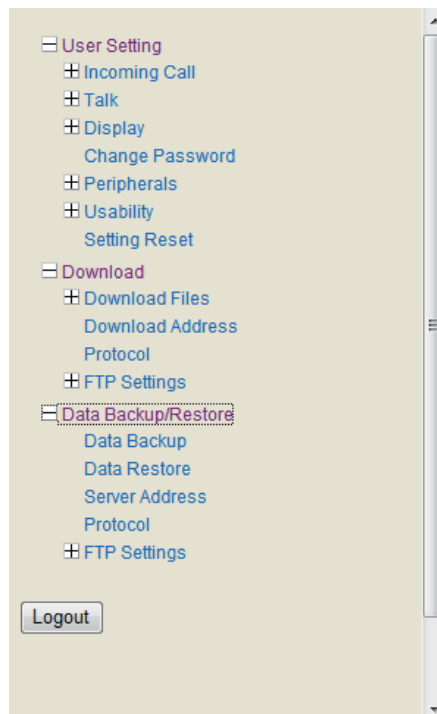

STEP 2: The confirmation message appears. Click **OK** to log out of Web Programming.

STEP 3: The display changes as follows. Click **Back**.



STEP 4: After the Web Programming Login screen is displayed, close the Internet browser.

**Note:** Make sure to perform the logout operation after the data setting of the telephone.

**Note:** When 10 minutes have passed leaving the PC without operation after log in to Web Programming, you are forcibly logged out from the Web Programming.

## HOW TO OPERATE

As an example of setting method on the Web Programming, the following explains how to change the ringer tone for external call. Web Programming includes the same menu configuration as “Setting” of DT830 Series terminal. For details on each menu item, see [MENU LIST](#).

STEP 1: From the **Home** screen, click **User Setting** → **Incoming Call** → **Ring Tone** → **External Call**.

STEP 2: Select a desired tone type by clicking the corresponding radio button.

STEP 3: Click **OK** to save the change to the database.

The screenshot displays the NEC DT800 Series Web Programming interface. The breadcrumb trail at the top reads: Home > User Setting > Incoming Call > Ring Tone > External Call. The left sidebar menu is expanded to show the 'External Call' option under 'Ring Tone'. The main content area shows a list of radio buttons for selecting a tone type, with '0. Automatic' selected. At the bottom of the dialog, there are 'Cancel' and 'OK' buttons. Blue lines and text boxes provide instructions for each step: STEP 1 points to the navigation path; STEP 2 points to the radio button selection; STEP 3 points to the 'OK' button. A 'Logout' button is also visible in the bottom left of the main menu.

STEP 1: Click items to navigate through the menu.

Click Logout button to exit from the Web Programming.

STEP 2: Click the radio button to select a parameter.

STEP 3: Click OK button to accept the selection.

STEP 4: A confirmation dialog appears. Click **OK** on the dialog.

# APPENDIX A OPTION DEVICES

## SMART DEVICE INTEGRATION

Connecting the optional Bluetooth® Connection Adapter (BCA-Z UNIT) to a terminal (DT830 Series/DT430 Series), the terminal can work in combination with smart devices (Tablets, mobile phones, etc.) that have Bluetooth® features.

By using the terminal in collaboration with a mobile phone, the following features are available on the terminal.

- Voice Call of the mobile phone
- Using mobile phone as the handset
- Hands-free call
- Playing music

When you start up a terminal connected with the Bluetooth® adapter, the Bluetooth® icon (  ) will be displayed on the LCD. If the Bluetooth® icon is not displayed, the Bluetooth® adapter is not normally connected to the terminal.

**Note:** For the combination with a mobile phone, both Path key and Connect key must be assigned as the Programmable Feature Keys on the terminal. If these keys are not assigned, the Bluetooth® adapter can not be operated. For details, please contact the system administrator.

### • To use Bluetooth® Features

The Connect key lamp indicates the connection status between DT830 Series/DT430 Series and the Bluetooth® device.

For details of the Connect key lamp status, see the table below.

Lamp Indication Patterns	Status
Turning Off	Indicates that Bluetooth® feature is OFF.
Lighting Red	Indicates that Bluetooth® feature is ON.
Flashing alternately Red and Green every one second	Pairing mode
Lighting Green	Indicates that mobile phone is connecting to Bluetooth®.
Flashing Green	Indicates the status when the mobile phone, which is connected to Bluetooth®, is in a call.

**Note:** Be sure to remove power for the terminal prior to adding or removing the BCA-Z adapter.

- **To pair Bluetooth® adapter with mobile phone**

DT830 Series/DT430 Series and a mobile phone can be connected through Bluetooth® by pairing the Bluetooth® adapter with the mobile phone.

For the terminal, a maximum of 8 pairing informations can be saved. However, the most recently connected mobile phone is connected through Bluetooth® first.

STEP 1: Confirm that Bluetooth® feature is OFF (Connect key lamp turns off).

STEP 2: Hold down the Connect key for over eight seconds to enable pairing mode. When the Connect key has been kept pressed three or more seconds, the Connect key lights red. However, to enable pairing mode, continue to press the Connect key until it lights alternately red and green.

STEP 3: The mobile phone scans for the Bluetooth® device, pairs itself with the Bluetooth® adapter, and connects to the terminal. For details of this procedure, refer to the manual of your mobile phone.

**Note:** If the terminal is not operated for three and a half minutes after terminal enters into pairing mode, the Bluetooth® feature will be enabled.

**Note:** If the terminal and mobile phone are already paired, the terminal and the mobile phone can be connected through Bluetooth® only operating with the mobile phone.

- **To enable Bluetooth® feature**

STEP 1: Press the Connect key several seconds (from three or more seconds to less than eight seconds) when the Bluetooth® feature is OFF (the Connect key is turn off).

STEP 2: The Connect key lights red, and the Bluetooth® feature turns ON.

**Note:** When the terminal starts up, the Bluetooth® feature will be automatically ON.

**Note:** When the Bluetooth® feature is ON, the Bluetooth® connection is made with the most recently connected mobile phone.

**Note:** If you press the Connect key for eight seconds or more, the terminal status will be Pairing mode (Flashing alternately Red and Green every one second).

- **To disable Bluetooth® feature**

STEP 1: Press the Connect key for several seconds (More than three seconds when the Bluetooth® feature is ON (the Connect key is turn on)).

STEP 2: The Connect key turns off, and the Bluetooth® feature turns OFF. The mobile phone, which is connected to Bluetooth®, will be forcibly disconnected.

**Note:** If the connection process between DT830 Series/DT430 Series and the mobile phone is performed during pairing mode, the Bluetooth® feature cannot be disabled.

**Note:** When the Connect key has not been pressed for 10 minutes while the Bluetooth® adapter is connected to the terminal, the Bluetooth® feature will automatically turn OFF.

- **Bluetooth® connection from DT830 Series/DT430 Series to mobile phone**

Bluetooth® connection is manually or automatically available between a terminal and a mobile phone whose pairing process has been completed. From the terminal, a Bluetooth® connection can be established only to the most recently connected mobile phone.

- **Automatic Connection**

STEP 1: Be sure to confirm that Bluetooth® connection is ON (the Connect key lamp lights red).

STEP 2: The most recently connected mobile phone must be within the range of a Bluetooth® connection (approximately 10 meters).

STEP 3: The Bluetooth® connection between the terminal and the mobile phone is established automatically.

**Note:** When Bluetooth® connection between the terminal and the mobile phone is established during a conversation, the voice communication is interrupted due to a switch to the Bluetooth® output. You can return to the conversation after 8 seconds since the voice communication is disconnected.



- Manual Connection

STEP 1: Be sure to confirm that Bluetooth® connection is ON (The Connect key lights red).

STEP 2: Press the Connect key less than 3 seconds.

STEP 3: The terminal sends a connection request to the most recently connected mobile phone.

STEP 4: Bluetooth® connection between the terminal and the mobile phone will be established.

- **To switch the call by using Bluetooth® feature**

When you leave the desk while talking in Mobile Phone Mode, you can switch from the call with terminal handset to the call with mobile phone. For the details of Mobile Phone Mode, see [TERMINAL MODE](#).

STEP 1: Press the Connect key less than 2.5 seconds. This operation is canceled by pressing the Connect key again.

STEP 2: The call switches from the terminal to the mobile phone. To switch the call using mobile phone, refer to the manual of your mobile phone.

## TERMINAL MODE

For DT830 Series/DT430 Series, there are two types of terminal mode called “Wired Telephone” mode and “Mobile Phone” mode. The terminal starts up on “Wired Telephone” mode by default.

- **Wired Telephone Mode**  
Enables the terminal to make a voice call as a station in the system.
- **Mobile Phone Mode**  
Enables the terminal to make a voice call for mobile phone.

**Note:** When the terminal is placed in Security mode, the Bluetooth® feature will be OFF even if the terminal is in busy/idle state. After that, the terminal mode switches to the Wired Telephone Mode.

**Note:** When the Security mode is canceled, the Bluetooth® feature will be ON. However, the terminal mode will be the Wired Telephone Mode.

- **To switch the terminal mode**

When the Bluetooth® connection between DT830 Series/DT430 Series and a mobile phone is completed, you can switch the terminal mode (“Wired Telephone” mode/“Mobile Phone” mode) by pressing the Path key.

The Path key indicates the mode status with the lamp color and the flashing status. When the Path key lights or flashes orange, the ter-

terminal is in Wired Telephone Mode. When Path key lights or flashes green, the terminal is in Mobile Phone Mode.

For details of the Path key lamp status, see the table below.

Lamp Indication Patterns	Flashing Periods	Mode	Status
Lighting Orange	-	Wired Telephone Mode	Indicates that the mobile phone is idle or not connected.
Flashing Orange	Slow Light	Wired Telephone Mode	Indicates that the mobile phone is originating a call or the terminal is talking through the DT830 Series/DT430 Series.
	Flash		Indicates that the mobile phone is playing music.
	Quick Flash		Indicates that you are talking on your mobile phone.
	Burst Flash		Indicates that the mobile phone is ringing.
Lighting Green	-	Mobile Phone Mode	Indicates that the terminal is idle on the system line or ringing.
Flashing Green	Quick Flash	Mobile Phone Mode	Indicates that the terminal is talking through the system line.

The flashing periods of Path key are as follows.

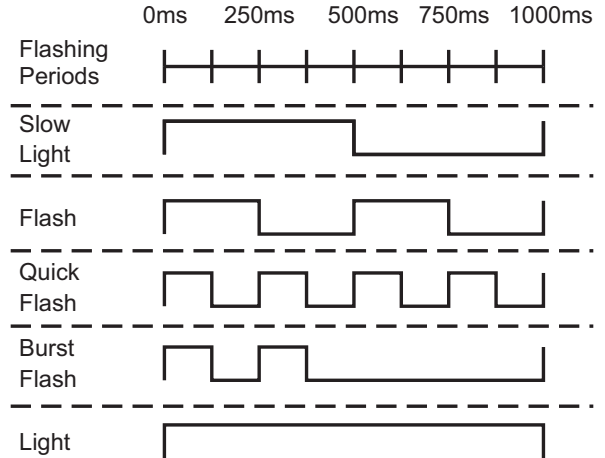

- **To switch between “Wired Telephone” mode and “Mobile Phone” mode**

STEP 1: Press the Path key when the terminal is in idle/ringing status.

STEP 2: The terminal mode is switched. When you lift the handset or the speaker is ON, the terminal mode cannot be switched.

- **To switch mobile phone answer mode**

Depending on the specifications of a mobile phone, the operation to start a conversation after answering the incoming call with the mobile phone is different. You can start a call smoothly by setting the mobile phone answer mode according to the specifications of each mobile phone. Choose the mobile phone answer mode corresponding to the mobile phone in use.

**Smart Device Type (Type 1):**

When you answer an incoming call with the mobile phone, the answered call will be switched from DT830 Series/DT430 Series to the mobile phone automatically.

**Note:** Depending on the type of mobile phone, a delay on the starting of the conversation may happen.

**Smart Device Type (Type 2):**

It is used for the type of mobile phones that delays the start of a conversation when it answers the call on Type 1.

**Note:** When you use this mode for a mobile phone that can start immediately a conversation with Type 1, the call may be on the DT830 Series/DT430 Series.

STEP 1: Press and hold the Path key when the terminal is in idle status.

STEP 2: You will hear a beep tone when the terminal mode is switched.

- Smart Device Type (Type 1): The beep tone sounds once.
- Smart Device Type (Type 2): The beep tone sounds twice.

**Note:** For details of recommended type of mode, contact the system administrator.

## OTHER FEATURES

- **To mute the hands-free microphone**

Hands-free microphone can be enabled/disabled by the following procedure while hands-free call is operated in the mobile phone mode.

STEP 1: Press the Mic key or the Feature key and **①** while hands-free call is operated.

STEP 2: When the microphone is enabled, the Mic key lights red. If the microphone is disabled, the Mic key turns off. Then, the microphone is in mute status.

- **To play music**

While Bluetooth® connection between DT830 Series/DT430 Series and a mobile phone is established, you can play music through the speaker of the terminal.

STEP 1: Play the music on the mobile phone. For more information about how to play music, refer to the manual of the mobile phone.

STEP 2: When the phone is hung up, the Speaker key lamp lights red and the music will be played through the speaker automatically. If you lift the handset while the music is playing, the music will come from the handset through the receiver. However, when you replace the handset on DT830 Series/DT430 Series, the music will stop.

STEP 3: Press the volume key to adjust the sound volume.

- **To stop music**

STEP 1: Press the Speaker key while the music sounds. The Speaker key lamp turns off and the music stops. If you press the Speaker key one more time, the music will be played again.

**Note:** To adjust the volume for the sound of the music, press the Volume key on the terminal. However, adjust the volume on the mobile phone for cases, such as when the adjusted sound is distorted, or the volume is low. Depending on the mobile phone model, the volume level cannot be adjusted.

**Note:** Even if you stop the music on the terminal, the music keeps playing on mobile phone. Therefore, be sure to stop the music on the mobile phone.

# APPENDIX B HEADSET OPERATION

## ATTACHING THE HEADSET

**Note:** The Headset key must be programmed in advance. For the programming of the Headset key, contact the system administrator.

Connect the headset to HEADSET connector on the back of the telephone following the procedure below.

**Note:** The headset which can be connected to the telephone is “HW251N-A10/WT100-EHS-NE/Voyager Legend CS (manufactured by Plantronics)”.

### • TO CONNECT THE HEADSET

STEP 1: Insert the modular plug into the HEADSET connector on the back of the telephone until it clicks.

STEP 2: Place the headset cord into the groove as shown in the figure below, and fix it.

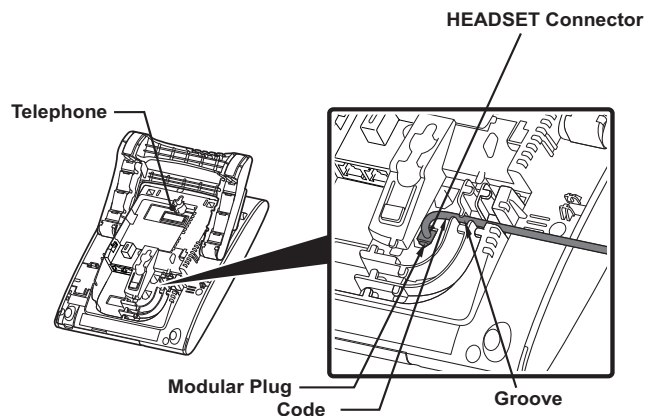

**Note:** To make a call with the headset, see [HOW TO INPUT CHARACTERS](#).

## TERMINAL OPERATION USING THE HEADSET

The following procedure explains how to operate a terminal using the headset. While using the headset, the operations equivalent to answering and ending a phone call are available by pressing the **Headset** key.

**Note:** The **Headset** key must be programmed in advance. For the programming of the **Headset** key, contact the system administrator.

### To Originate a Call

- STEP 1: Press the **Headset** key, and the **Headset** key lights red.
- STEP 2: The line key lights green and dial tone is received.
- STEP 3: Dial a desired telephone number, after the target party answers the call, you can start a conversation.

- STEP 4: Press the **Headset** key to end the call, and the **Headset** key turns off.

**Note:** To switch to handset mode, lift the handset and press the **Headset** key during a conversation.

### To Answer a Call

- STEP 1: Press the **Headset** key while the ringing tone is on, and the **Headset** key lights red.
- STEP 2: Press the flashing line key to start a conversation with another line. Depending on the settings at the installation phase, you can answer the call by pressing **Answer** key instead of line key.
- STEP 3: Press the **Headset** key to end the call, and the **Headset** key turns off.

**Note:** To switch to headset mode, press the **Headset** key during a conversation.

## ADJUSTING HEADSET RINGER TONE VOLUME

You can adjust the ringer tone volume for a headset in an idle or a busy state.

**Note:** To pass a ringer tone through the headset, enable “Headset Ring” from the **Settings of Menu** screen. For the details, refer to “Menu List For Setting”.

**Note:** Ringer tone volume can be adjusted only for a wired headset connected to the terminal headset connector.

**Note:** Ringer tone volume in busy state cannot be changed when the ringer tone is set to come from both the speaker and the headset. For details, contact the system administrator.

### To Adjust the Ringer Tone Volume in Idle Status

STEP 1: Press the **Headset** key while in idle status to switch from headset mode to handset mode, and the **Headset** key lamp turns off.

STEP 2: Receives a call from another line.

STEP 3: Press the **Up/Down** () key while a ringer tone is on.

### For Ringer Tone Volume in Busy Status

If other lines are accommodated in the telephone as a subline, the ring tone volume of a subline call received while being in the middle of a call through the headset will be lower than usual.

**Note:** When you receive another call during a call through the headset, the ringer tone volume for other lines in headset mode can be set to the same level as the normal two-way call. For details, contact the system administrator.

## HOW TO USE THE WIRELESS HEADSET

When using Wireless Headset, you can answer a call, conduct a conversation, or disconnect the call with hooking operations. Here explains about the terminal operation using Wireless Headset.

**Note:** The **Call control button** of Wireless Headset must be programmed in advance. For the programming of the **Call control** button, contact the system administrator.

**Note:** For details on how to connect a telephone and Wireless Headset, see the manual attached to the Wireless Headset.

### To Answer a Call

STEP 1: Press the **Call control** button of the Wireless Headset while the ringing tone is on, and the **Call control** button lights red. Depending on the installation phase, you can answer the call by pressing  key instead of **Call control** button.

STEP 2: Press the **Call control** button to end the call, and the **Call control** button turns off.